

**Hisense**  
life reimagined

Hisense International Co., Ltd.

Add: Hisense International Center, No. 88 Xianggang East Road, Qingdao, China  
E-mail: [marketing@hisense.com](mailto:marketing@hisense.com)  
Website: <http://www.hisense.cn/en>

Add: 08 Ronggang Road, Ronggui, Shunde, Guangdong, China.  
E-mail: [marketing@hisense.com](mailto:marketing@hisense.com)  
Website: <http://www.hisense.cn/en>

Note: Product design and specification subject to change without prior notice.

© 2026 Hisense Corporation. All rights reserved. Hisense and the Hisense logo are trademarks or registered trademarks of Hisense Group in China and/or other countries. All rights reserved. The Hisense Smart TV logo, Ultra HD High Definition logo, SMR logo and life reimagined logo are trademarks or registered trademarks of Hisense Electric Co., Ltd. in China and/or other countries. All rights reserved. All other company names, brand names, trademarks and logos are the property of their respective owners. All rights reserved.

**Hisense HVAC**

**HISENSE LCAC EU**

**CATALOG 2026**



# GLOBAL LCAC

Hisense LCAC is committed to providing customers with more reliable and more efficient products, and adheres to uniform high-quality standards for products to different countries and regions around the world.



## CONTENT

### 01

**ABOUT HISENSE**

### 41

**PRODUCT HIGHLIGHTS**

Carbon Neutral Eu 2050	41
Deep Cool	43
Twin, triple And Quadruple System	45
Multizone	47
Intelligent Control	48

### 51

**SPECIFICATIONS**

### 84

**TECHNICAL DRAWINGS**

### 109

**CONTROL SYSTEM**

### 11

**LIGHT COMMERCIAL AIR CONDITIONERS**

11	Compact Cassette
15	Round Flow Cassette
23	Slim Duct
25	MSP Duct
27	HSP Duct
29	Ceiling Suspended
31	Console
35	Floor Standing
37	Outdoor Unit

### 49

**LINEUP**

### 71

**FUNCTION OVERVIEW**

### 103

**QUICK SEARCH GUIDE**

# HISENSE TRAINING CENTER

## Italy Training Center

Hisense HVAC Italian Training Center, located in Milan, Italy, Europe, is an AAAAA Hisense training center all over the world, where showing and training products include RAC, FM, LCAC, VRF, ATW, DHW, etc. The training center conducts online and face-to-face training for customers all over Europe. The exhibition area of the training center will display Hisense's latest HVAC products and technologies.



## Better Training and Service

At present, the Italian training center has established a comprehensive training system that integrates online and face-to-face training methods, as well as theory and practice, providing customers with professional HVAC knowledge and enhancing service quality.

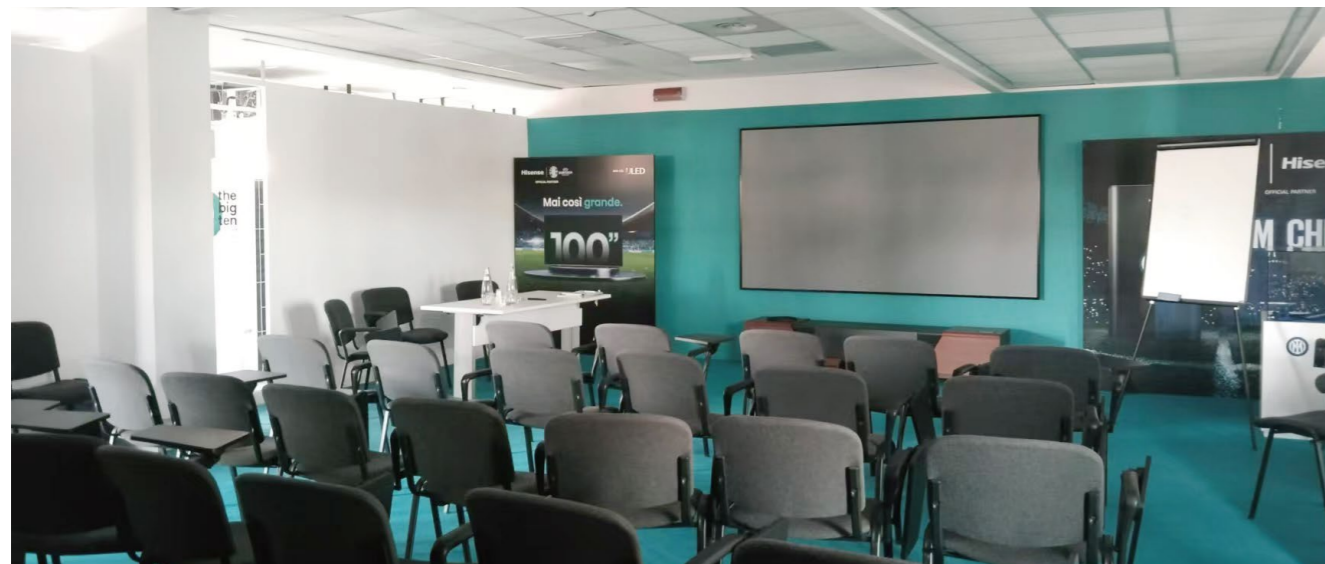

### Spain Central Training Center

By Hisense Iberia

📍 Madrid, Spain



### France Training Center

With Partner ALDES

📍 Leon, France



### Greece Training Center

With Partner DENKI

📍 Athens, Greece



### Poland Training Center

By Hisense Poland SBU

📍 Warsaw, Poland

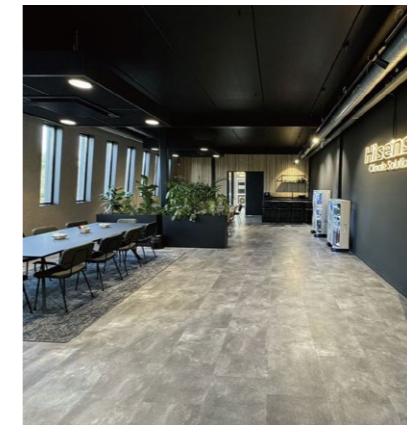

### Netherlands Training Center

With Partner HS

📍 Dordrecht, Netherlands



### Germany Training Center

With Partner KAUT

📍 Nordrhein-Westfalen, Germany



### Spain North Training Center

With CENTRE TECNIC EUROPEU

📍 Barcelona, Spain



### Slovakia Training Center

With Partner Powering SK

📍 Bratislava, Slovakia



### Portugal Training Center

With Partner JFS

📍 Lisbon, Portugal

# REFERENCE PROJECT LIST

Hisense LCAC products are sold in Italy, Spain, Portugal, Germany, France, Netherlands, Belgium, Austria, Serbia, Poland, Czech Republic, Bulgaria, Greece, Ukraine, Romania and many other countries. We have won more and more customers with LCAC reliable operation .



**Firenze, Italy.**  
Light Commercial duct and cassette in the restaurant and living areas, RAC in the dressing rooms.



**Rimini, Italy.**  
RAC installation mixed with Light Commercial duct and cassette.



**Córdoba, Spain.**  
130 flats developed by Kronos Homes and called "Tribeka".



**Málaga, Spain.**  
80 flats developed by Voltiam.



**Belgrade, Serbia.**  
The Plot 21a of the Belgrade Waterfront.



**Kolasin, Montenegro.**  
Hotel Bianca Resort & Spa.



**Warsaw, Poland.**  
Delicatessen downtown.



**Bucharest, Romania.**  
In cooperation with mit clima.

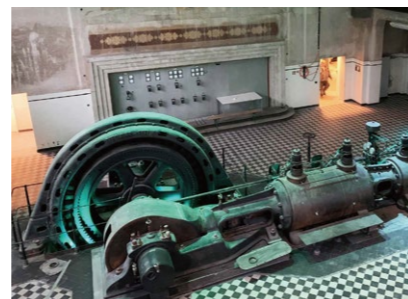

**Solingen, Germany.**  
Machine hall with historic steam engine.



**Venice, Italy.**  
LCAC 2xTriple Cassettes Solution in the restaurant Reeb's



**Modena, Italy.**  
Cassette, 7x AUC140, with 1 central control system  
SuperMarket PACE MERCATONE



**Lisbon, Portugal.**  
Aeroporto de Lisboa  
LCAC Floor Standing and VRF 2-way Cassette System



**Airport Bratislava, Slovakia.**  
Logistic Depo DHL  
Big capacity duct units for heating



**Mauritius  
Pan-European region**  
RAC, Compact Cassette,  
Cassette with Hi-Multi Solution

# HI-SERVICE SOLUTION

## Intelligent Service Management Platform

Hi-Service is a mobile management platform provided by Hisense for service provider and technician, mainly realizing functions such as work order management, technical support, spare parts management, and technician management. It can assist technician in conveniently, quickly, and professionally search error codes, troubleshooting solutions, and repair plans. It can also allow technician communicate with Hisense's technical team in real-time online, improving service efficiency and symptom resolution rates.

### Easy to Access

- Step 1:** Scan the QR code to download the installation file.
- Step 2:** Install Hi-service APP on the phone.
- Step 3:** Open and use it.

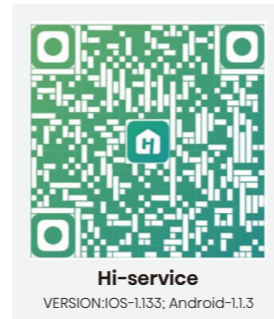

### Follow the following steps to login

**Username** (Field: 200625)

**Password (default): qwe6853S**  
Please change the password after first login.

**Service Provider is the account for service manager.** (Selected: Service Provider)

**Technician is the account for service man.** (Selected: Technician)

**Please read the Terms & Conditions, and privacy policy before login.** (Field: I have read the Privacy Policy and I agree to the Terms and Conditions)

- Knowledge Base**: Allow technician to retrieve info in Hisense knowledge base system
- Error Code**: To search for product error code info, click on the "Error Code" box
- Symptoms**: Not available for HVAC. It is for other kind of product
- Check**: Connect with checker box via Bluetooth to read data from air conditioner
- Technical Live Chat**: Not available for HVAC. It is for other kind of product
- RMA**: Not available for HVAC. It is for other kind of product
- Energy Label**: Help technicians to search for Hisense Multi Split energy labels online
- GSD**: Search for technical docs from Gorenje's knowledge base

- Note:**
- The service provider can add the technician account by User → My Technicians → Add.
  - The user can recommend the app to friends by User → Install QR Code.
  - The user can check the version by User → App Version. And Hi-Service will update to provide better service without prior notice.

- Error code:** App will display detailed information of the error code selected. Technician can view fault description, reason, trigger condition and its solution of the error code selected.
- Check:** Data returned from Hi-Checker 3.0 will be shown here, it will be refreshed automatically every few seconds.

- Energy label:** It will help to get the energy label and fiche for Hi-Multi SP models below 12kW.
- GSD:** It is Gorenje GSD Knowledge base, with the same GSD account and password in the computer.

# ENERGY LABEL

To enable consumers to compare and make purchasing decisions based on uniform labelling criteria, Europe has introduced energy labels. The previous European energy label for air conditioners, introduced in 1992, did its job for the time. In 2013, Europe introduced a seasonal energy label. This label allows end users to make even more informed choices, since seasonal efficiency reflects air conditioner efficiency over an entire season.

The energy label includes multiple classifications from A+++ to D, reflected in colour shadings ranging from dark green (most energy efficient) to red (least efficient). Information on the label not only includes the seasonal efficiency ratings for heating (SCOP) and cooling (SEER), but also annual energy consumption and noise levels.

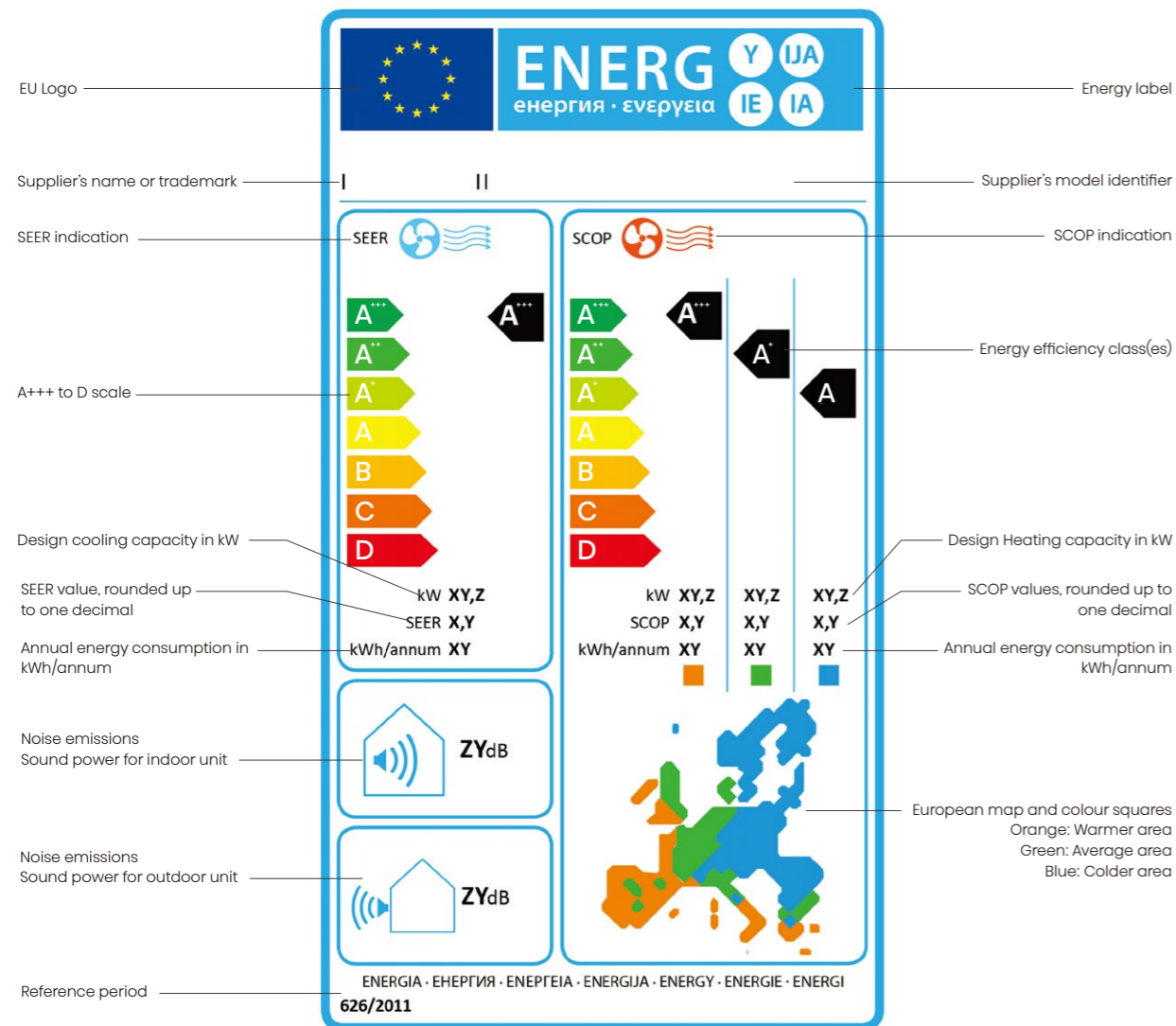

# CONDITIONS & CONVERSION

## Cooling

### EER test:

Indoor temperature 27°CDB, 19°CWB  
Outdoor temperature 35°CDB.

### SEER Test:

Condition	Part Load Ratio	Outdoor Air Dry Bulb Temperature °C	Indoor Air Dry Bulb (Wet Bulb) Temperature °C
A	100%	35	27 (19)
B	74	30	27 (19)
C	47	25	27 (19)
D	21	20	27 (19)

## Heating

### COP test:

Indoor temperature 20°CDB Outdoor temperature 7°CDB, 6°CWB.

### SCOP Test:

Condition	Part Load Ratio In %			Outdoor Heat Exchanger	Indoor Heat Exchanger
	A	W	C	Inlet dry (wet) bulb temperature °C	Indoor air dry bulb temperature °C
A	88	NA	61	-7(-8)	20
B	54	100	37	2(i)	20
C	35	64	24	7(6)	20
D	15	29	11	12(11)	20
E	(TOL - 16) / (Tdesignh - 16)			TOL	20
F	(Tbiv - 16) / (Tdesignh - 16)			Tbiv	20
G	NA	NA	82	-15	20

## Sound Level

The sound pressure level is measured via a microphone at a certain distance from the unit. It is a relative value, depending on the distance and acoustic environment (for measuring conditions: please refer to the technical databooks). The sound power level is an absolute value indicating the "power" which a sound source generates. For more detailed information please consult our technical databooks.

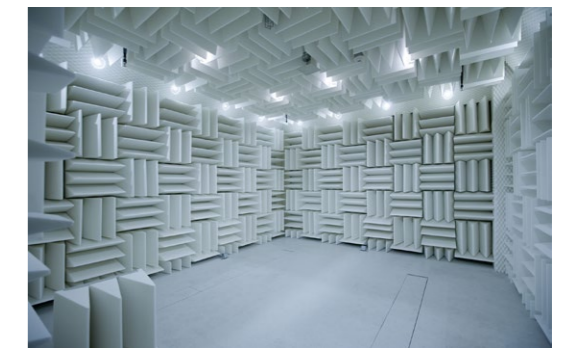

## Conversion Data

- kW x 3412 = btu/h
- °C x 1.8 + 32 = °F
- bar x 14.51 = psi
- m<sup>2</sup> x 10.76 = ft<sup>2</sup>
- l/s x 3.6 = m<sup>3</sup>/h

## Pipe Size

- 1/4in = 6.35mm
- 3/8in = 9.52mm
- 1/2in = 12.70mm
- 5/8in = 15.88mm
- 3/4in = 19.05mm
- 7/8in = 22.22mm
- 11/8in = 28.58mm
- 13/8in = 34.93mm

CE 0035



# 6 REASONS FOR HISENSE LCAC

## 1 Full Outdoor Line Up

System	Type	Model	Product Name	9K	12K	14K	18K	21K	24K	30K	36K	42K	48K	60K	75K	85K
				26	35	40	52	60	71	90	105	125	140	175	200	250
Air To Air		<b>Turbo Inverter R32</b> *High Efficiency SEER up to 7.5, SCOP up to 4.6 *Deep Cool *Pair, twin, triple, quadruple *Max piping 100m in TI climate *Service Window *Average and Warmer SCOP available	AUW##8													
		<b>Super Inverter R32</b> *Very compact outdoor units for easy installation *Balance of efficiency and cost *Max piping 50m *Service Window *Average and Warmer SCOP available	AUW##7													

## 2 Full Indoor Line Up

Hisense can offer many kinds of indoor unit, including 600\*600 Compact Cassette, 900\*900 Round Flow Cassette, Console Standing, Ceiling Suspended, H190mm Slim Duct, 150Pa MSP Duct, 200Pa HSP Duct, 250Pa HSP Duct, Floor Standing.

	600*600 Compact Cassette		H 190mm Slim Duct	
	900*900 Round Flow Cassette		H 245mm 150Pa MSP Duct	
	Console Standing		H 300mm 200Pa HSP Duct	
	Ceiling Suspended		H 420mm 250Pa HSP Duct	

\* Hisense 1-way Cassette is on pre-developing.

## 3 Higher Efficiency

- SEER up to 7.50, A++ level for cooling
- Average SCOP up to 4.60, A++ level for heating
- Warmer SCOP up to 5.40, A+++ level for heating
- EER up to 4.41 W/W in full load
- COP up to 4.50W/W in full load

Outdoor	SEER Up to	SCOP-A Up to	SCOP-W Up to
AUW-09U4RS8	A++	A++	A+++
AUW-12U4RS8	A++	A++	A+++
AUW-14U4RJ8	A++	A++	A+++
AUW-18U4RJ8	A++	A++	A+++
AUW-21U4RK8	A++	A++	A+++
AUW-24U4RK8	A++	A++	A+++
AUW-30U4RK8	A++	A++	A+++
AUW-36U4RW8	A++	A++	A+++
AUW-36U6RW8	A++	A++	A+++
AUW-42U4RW8	297%	177%	213%
AUW-42U6RW8	297%	177%	213%
AUW-48U4RW8	277%	177%	213%
AUW-48U6RW8	277%	177%	213%
AUW-60U6RW8	241%	157%	205%
AUW-75U6RZ8	237%	153%	193%
AUW-85U6RZ8	230%	153%	193%

## 4 Top Stability

- Ensure voltage fluctuation stability down to 176V.
- Ensure reliability in ultra-low temperature and long piping by testing compressor oil viscosity.
- Ensure PCB heat transfer reliability by the PCB refrigerant cooling design. Outdoor temperature can reach up to 52°C.
- Ensure drainage reliability by standard float switch for Slim Duct, MSP Duct, HSP Duct, Compact Cassette and Cassette.
- Ensure drainage smooth by standard built-in pump for Slim Duct, MSP Duct, HSP Duct, Compact Cassette and Cassette.
- Ensure the system not exceed the design pressure by high pressure protector and low pressure protector.
- Ensure no dripping in high humidity conditions by anti-condensation smart control.
- Ensure no overflow from the drain pan by the big drain pan design, when the water from the drain pipe is returned in suddenly power off.
- Ensure the stability in extra-low heating by compressor E-heater and bottom E-heater.

## 5 Faster and Flexible Installation

- Easy Cardboard for Compact Cassette, Cassette, Ceiling Suspended, and Console units, can help install the indoor unit fast.
- The double 3-way stop valves, not matter built inside or outside, can help to vacuum fast.
- Compact design of the indoor units and outdoor units can help to carry and install easily. The compact cassette is only 15.5kg and 215mm height to be NO. 1 in class.
- The suction grille can be adjusted in any direction. And the appearance looks just the same.
- Rear suction and bottom suction of duct unit can be adjusted in the project site.

## 6 Smart and More Comfort

- 888 hidden display gives the precision of control is 0.5°C and the precision of display is 0.1°C.
- Individual airflow can be controlled by the wired controller or the remote controller.
- The display panel will flash in the direction of individual control airflow.
- Connect Life WiFi Control.
- It has On/Off models 1 to 7 to meet different kinds of input control demand.
- Smart eye can detect the people in each of the 4 areas. When there are no people in a room, the system automatically change to energy saving mode.
- Round Flow can get better air supply and outlet temperatures



# COMPACT CASSETTE

## Compact Design

The compact design with body thickness of only 215mm reduces the ceiling height. The compact design makes the most slim design in class.

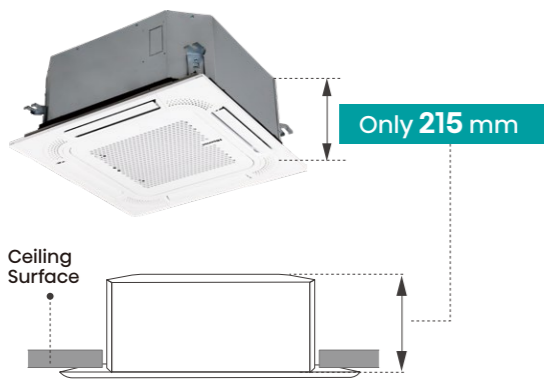

MODEL	W×H×D (mm)
9K	570×215×570
12K	570×215×570
14K	570×215×570
18K	570×215×570

## 620×620 Panel

The 620\*620mm panel is very fit for the standard decoration panel, without covering other things. So it can be beautiful and easily installed.

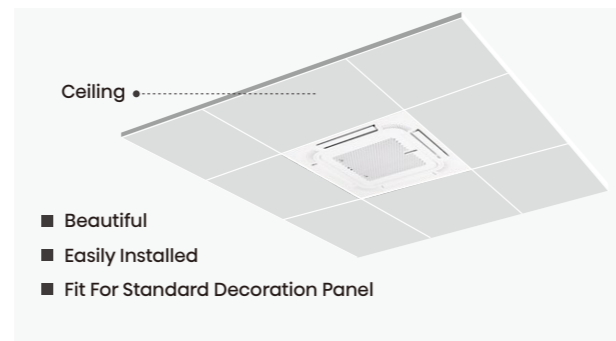

## Round Flow

Round flow air supply optimizes room airflow, ensuring that the comfortable airflow goes to every corner and that the temperature perfectly balance the integral space.

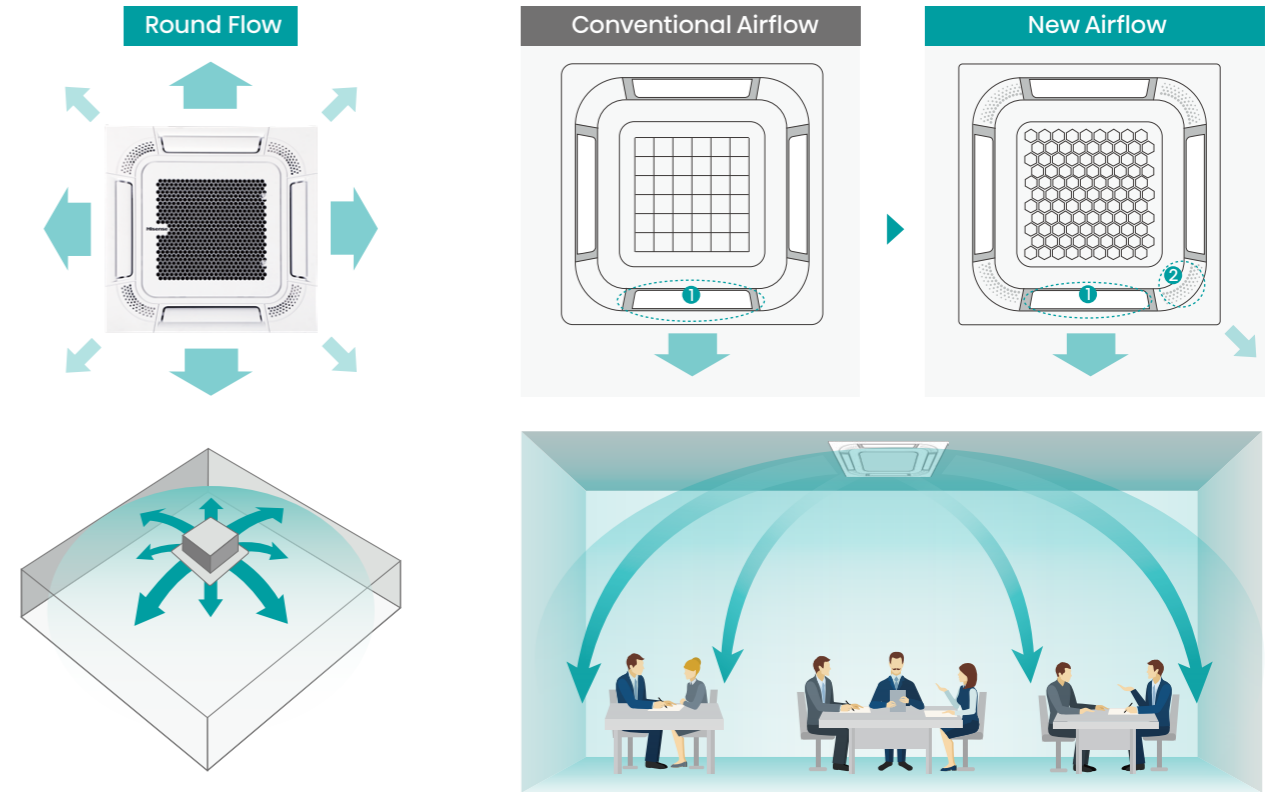

## Individual Airflow Control

Independent airflow control perfectly caters to the space structure and feelings of different people.

\* We can achieve individual airflow control by wired controller YXE-E01U(E) or remote controller RCH-RVD01.

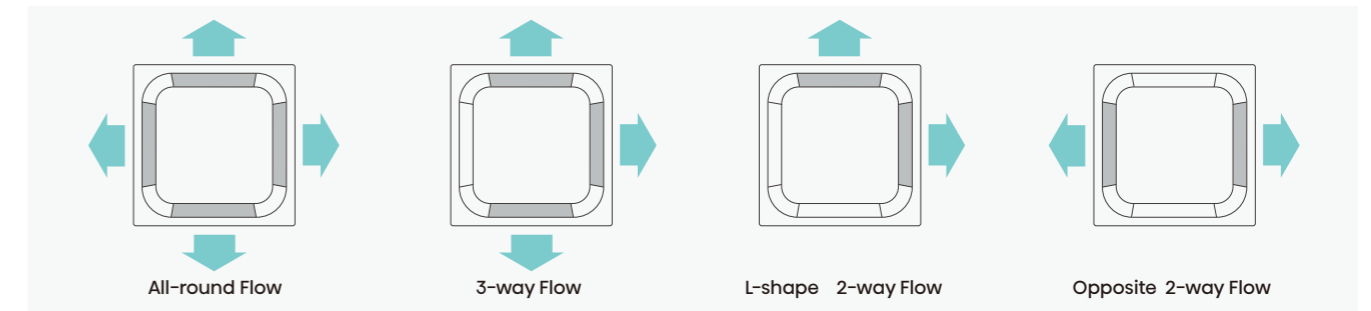
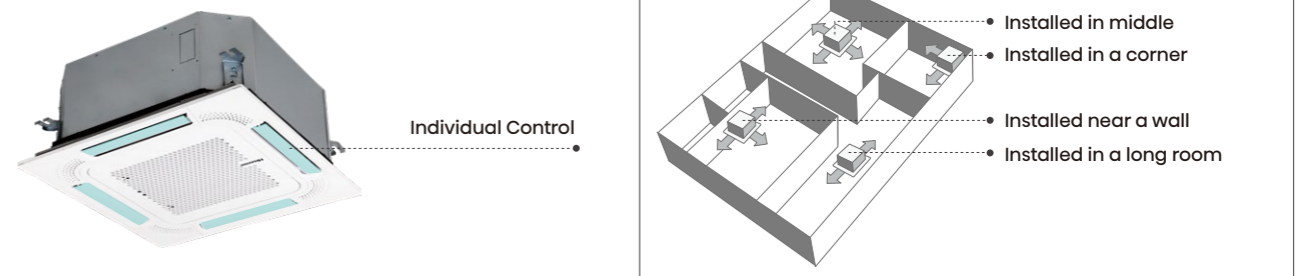

## High Ceiling

When the ceiling is high, the unit parameters can be set by the wired controller to compensate the installation height. Even in spaces with high ceilings, a comfortable airflow is carried down to the floor level.

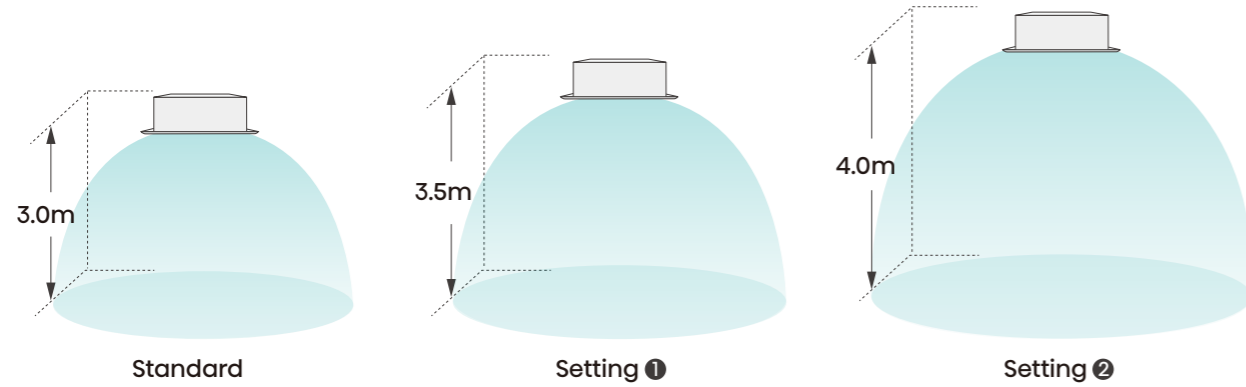

## High Efficiency Coil

The compact cassette adopts the advanced 5mm narrow tube spacing heat exchanger, so that a more powerful and efficient heat exchanger can be arranged in such a limited space.

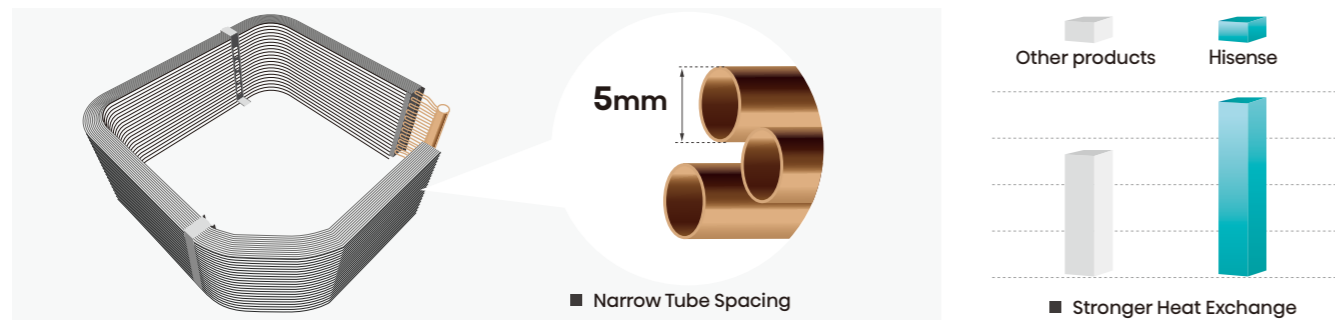

## Humidity Control

The humidity sensor is standard for compact Cassette. In dry mode, the room relative humidity can be displayed by wired controller YXE-E01U(E).

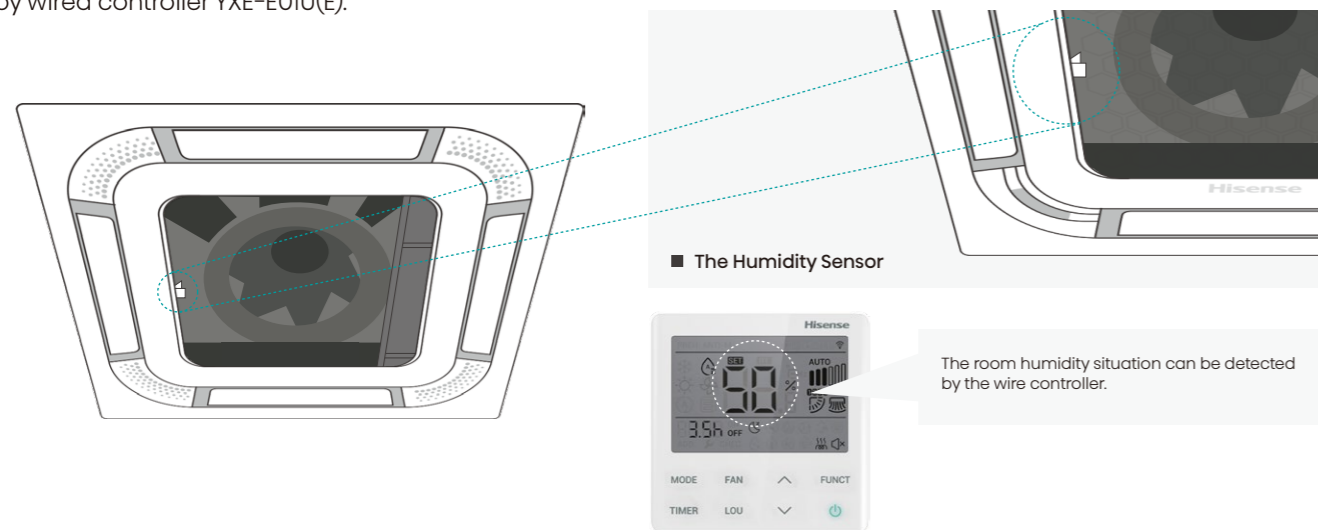

## Inner High Lift Pump

The maximum lift of Hisense high lift pump components can be as high as 1200mm.

\* In order to ensure smooth drainage in long-term operation, the recommended drainage height is <800mm.

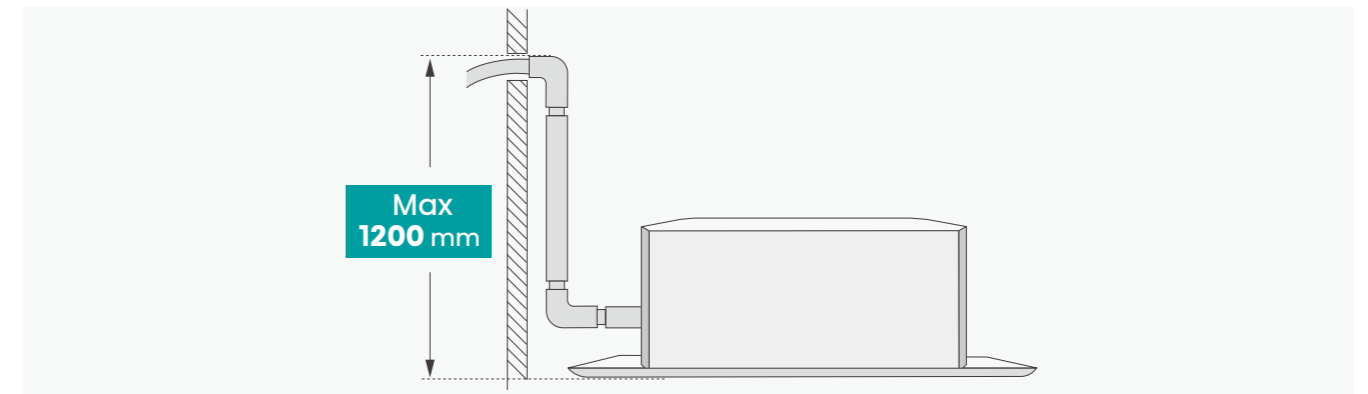

## Fresh Air Intake

The fresh air intake can introduce the outdoor fresh air into the room to improve the indoor air quality.

\* The fresh air volume cannot exceed 20% of total design air volume.

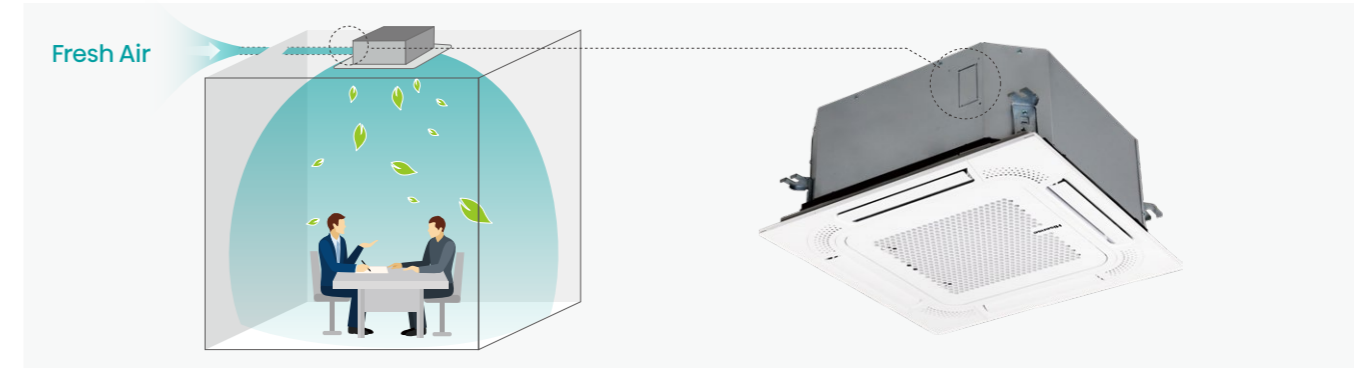

## Ag<sup>+</sup> Healthy Filter

The Ag<sup>+</sup> healthy filter is equipped as standard, which can effectively inhibit the breeding of bacteria and viruses, thereby ensuring a healthy room air supply.

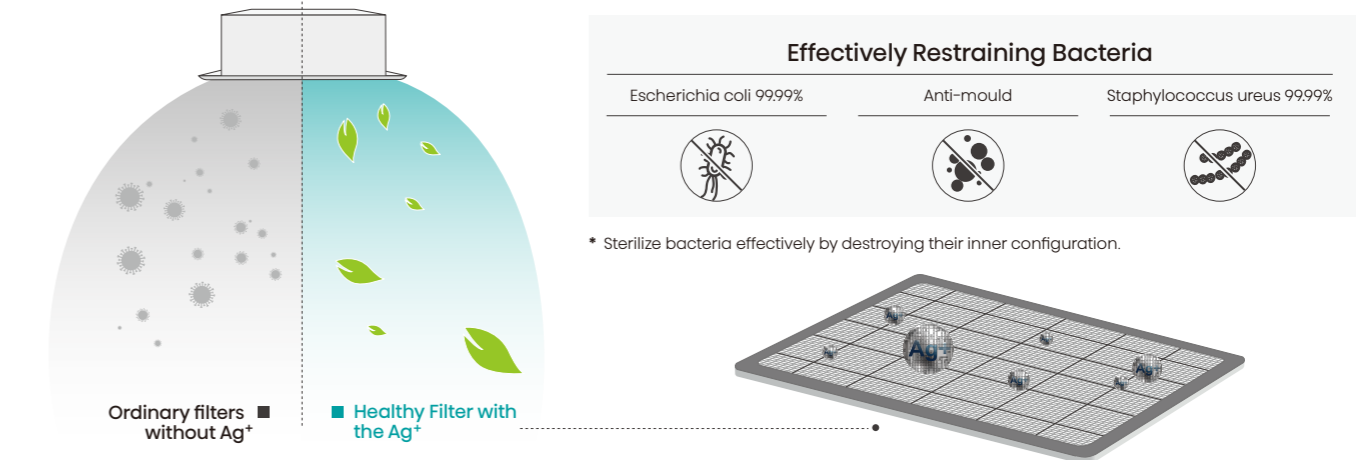

# ROUND FLOW CASSETTE

## Round Flow

Round air supply optimizes room airflow, ensure the comfortable airflow goes to every corner and the temperature perfectly balance the integral space.

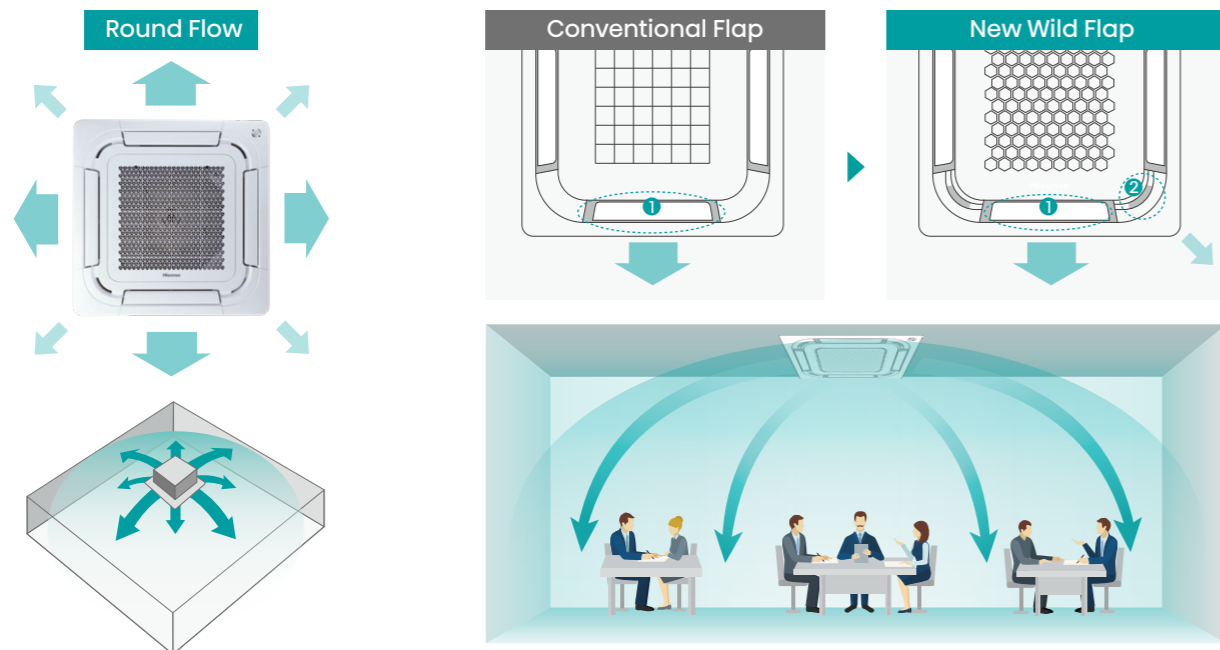

## Individual Airflow Control

Independent airflow control perfectly cater to the space structure and feelings of different people.

\* We can achieve individual airflow control by wired controller YXE-E01U(E) or remote controller RCH-RVD01.

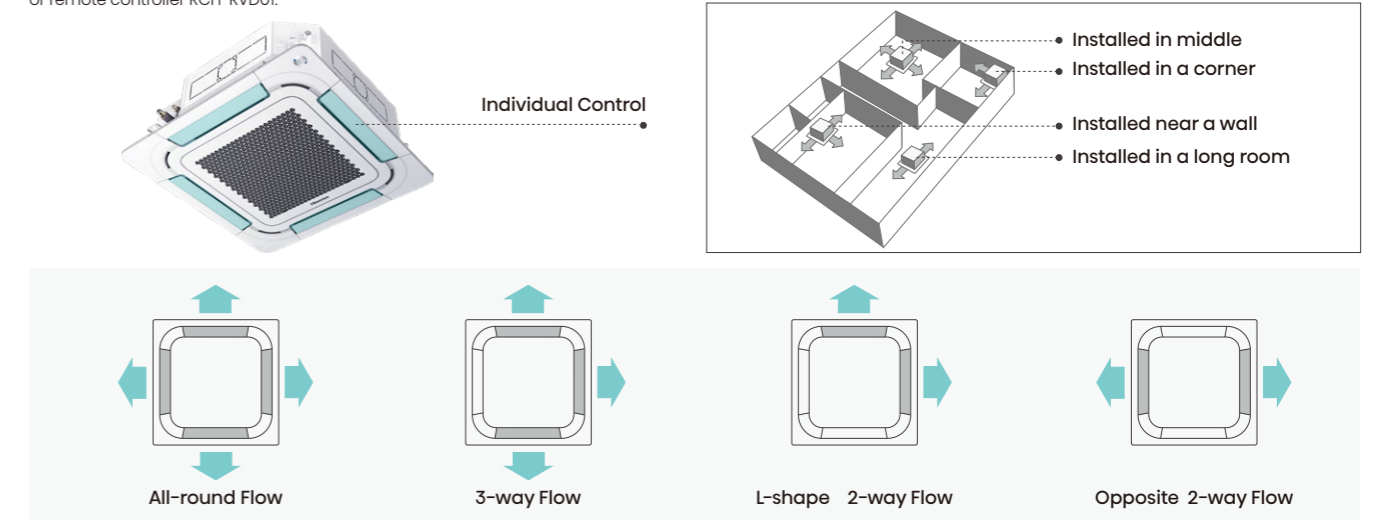

## Airflow Display

When the individual airflow is changed the display of corresponding direction will flash.

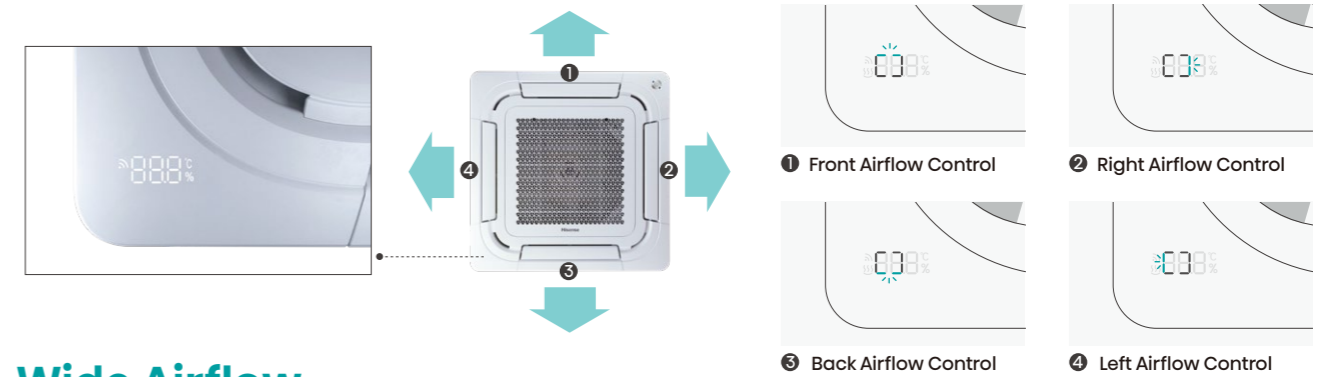

## Wide Airflow

The swing airflow can widely reach up to 88°. Thanks to wide airflow, we can get the cooling ceiling airflow and strong heating airflow.

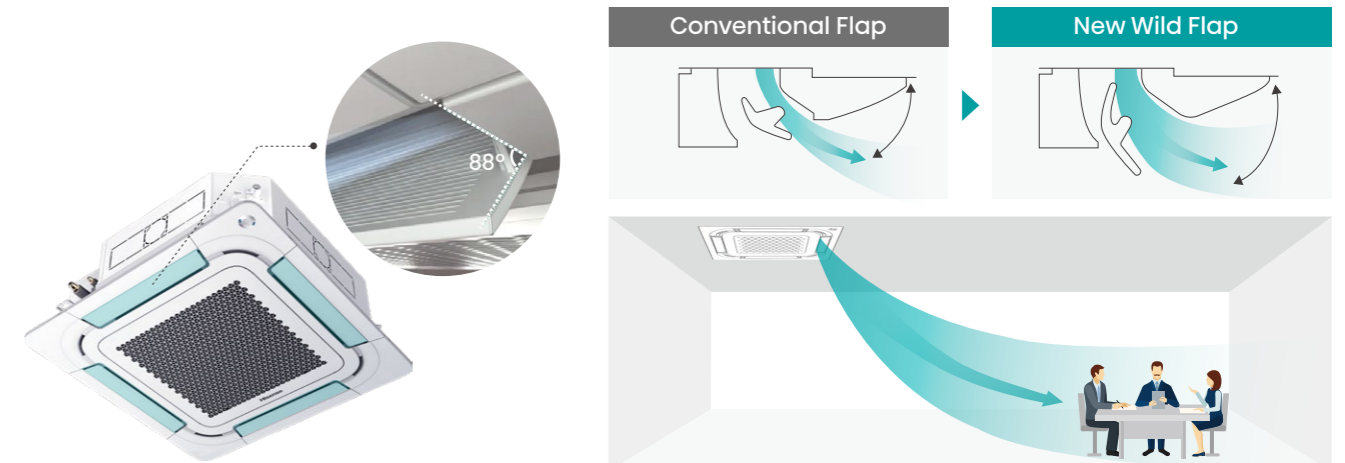

# Smart Eye

## Dual sensors smart eye design

Dual Sensors can work together to detect the presence of people in each of 4 areas. The detective areas can be more than 50% wider than one sensor design. The sensor is based on thermal imaging technology and the detection do not need the large movement of people.

\* It is recommended to keep ceiling height more than 3.5m to reduce the blind areas of the sensors.

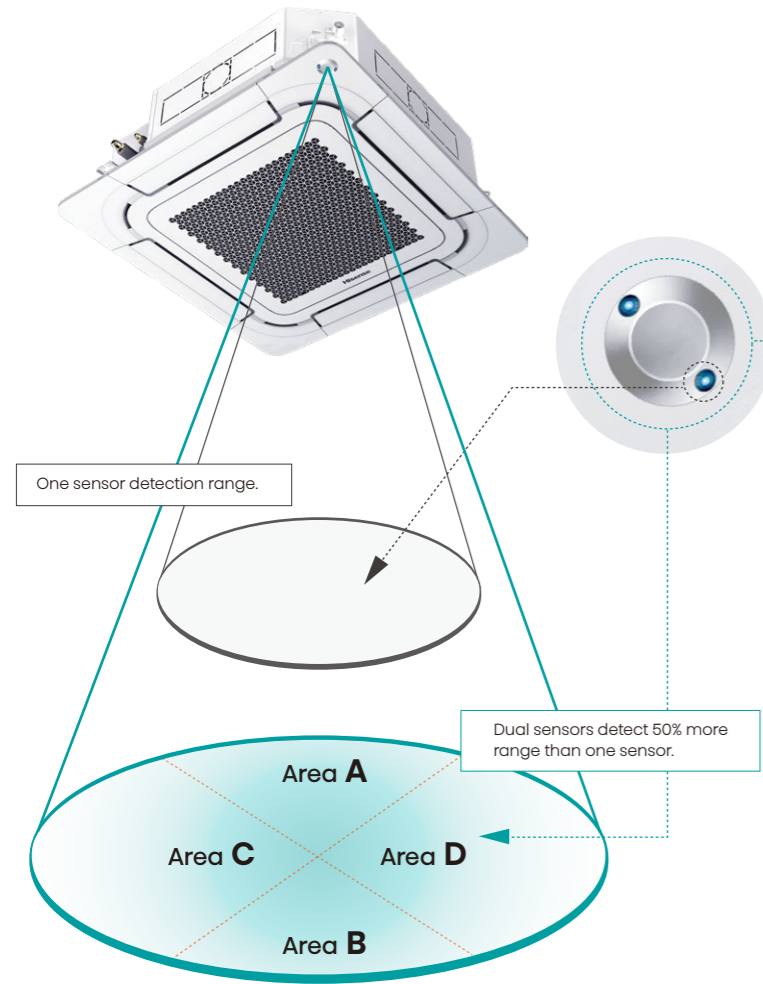

## Thermal infrared sensing imaging

After comprehensive evaluation of detection delay time, sensor accuracy, personal privacy and size, the dual infrared sensor solution was finally adopted.

\* Human detection is not possible for the blind area of the sensor. The detection may sometimes be effected by a heat source, window or some device emitting heat.

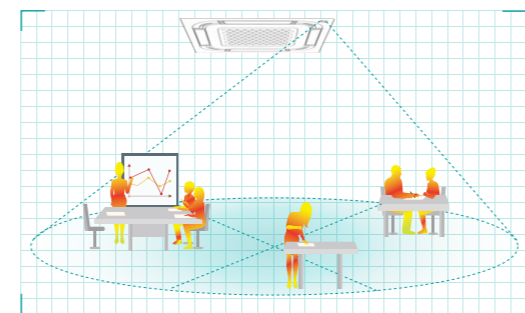
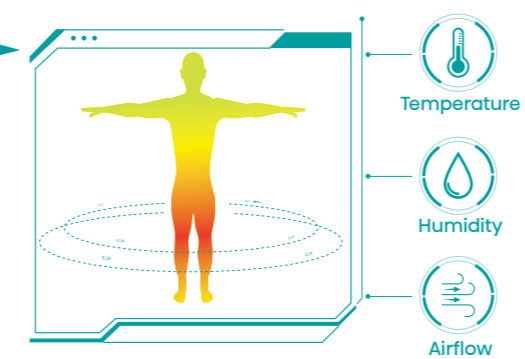

## Independent airflow design

Airflow of 4 areas can be controlled smartly and independently according to the presence of people. In human avoid mode, the airflow of human detected area will come into ceiling airflow, and the airflow of no human detected area just keep the normal airflow.

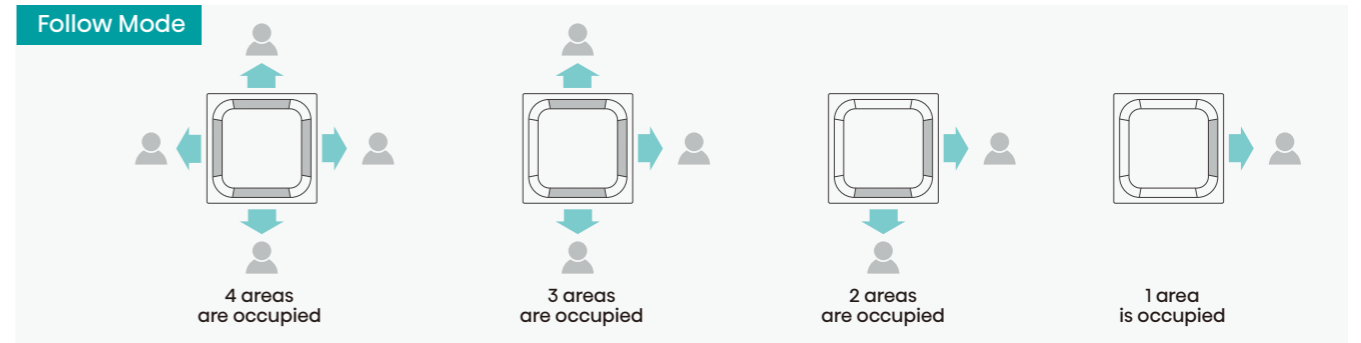
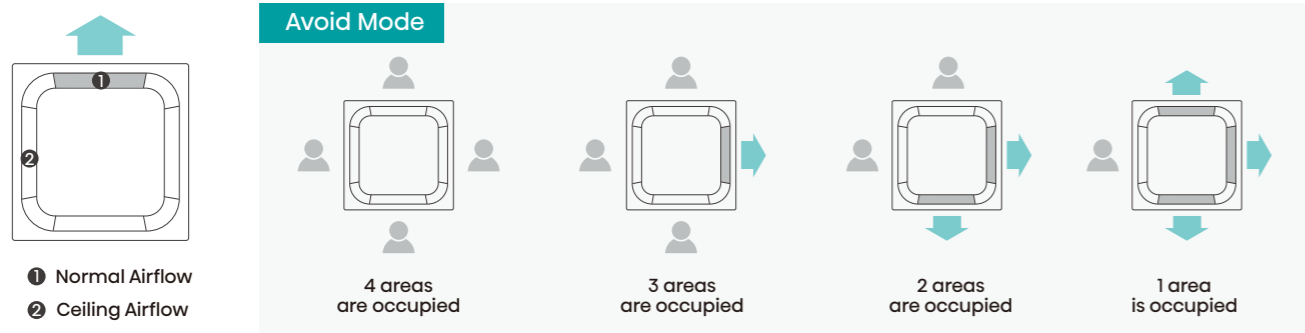

## Saving mode state ( default: ON )

The system will automatically save energy by detecting whether or not people is in the room. And when people return to the room, the system will come back to the setting people leaving.

\* We can change saving mode to ultra-saving mode by field settings.

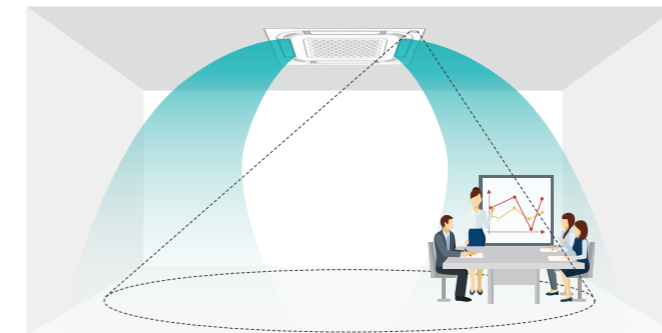
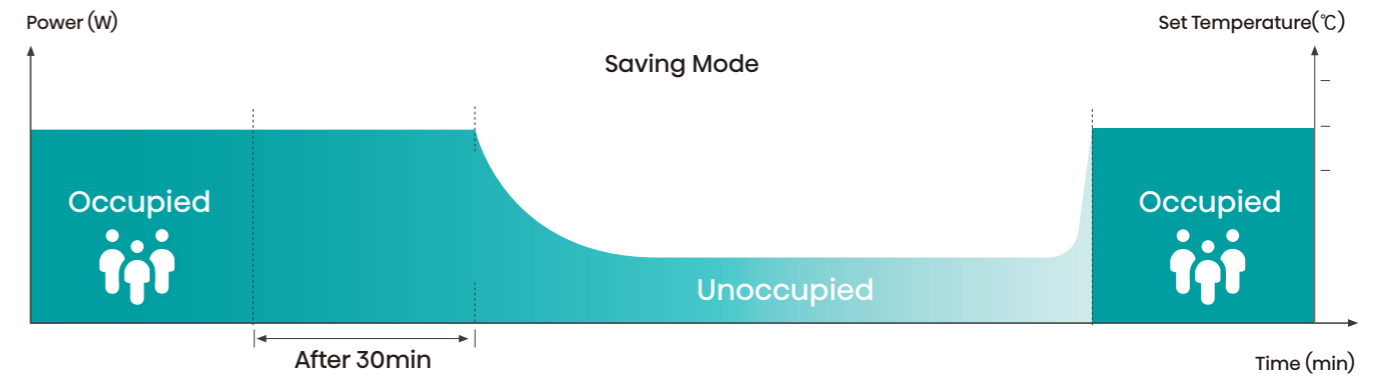

■ Normally For People In The Room.

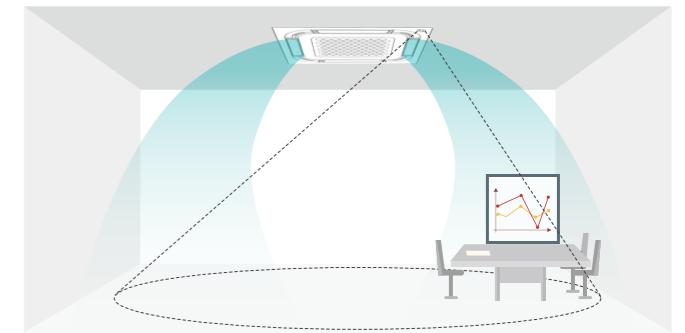

■ Energy Saving for no people in the room.

## Ultra-saving mode state ( default: OFF )

When there are no people in a room, the system stops automatically.

- The system automatically saves energy by detecting whether or not the room is occupied.
- Based on preset user conditions, the system automatically stops operation if the room is unoccupied.

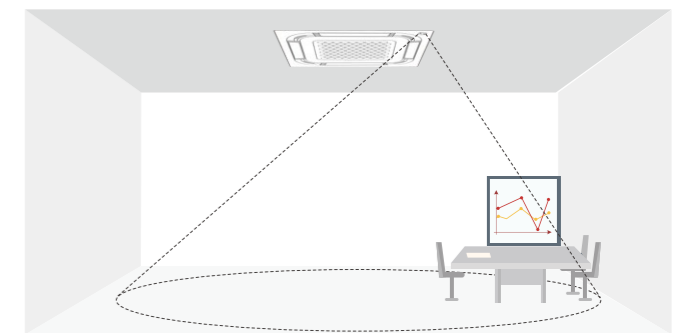

■ Stand by for no people in the room.

## High Efficiency Coil

The cassette adopts a G type design with a larger heat exchange area. Compared with traditional heat exchanger, it is more high-efficient and more power-saving.



## HI-NANO

HI-NANO can effectively prevent bacteria. Release a large number ion stream, kill and remove bacteria and viruses quickly through the recycle indoor air.

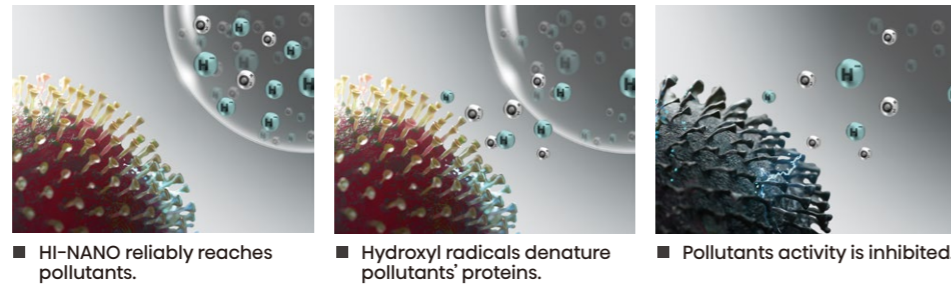

HI-NANO Sterilization Type			
92.6% of HINI	88.54% of E. coli	74.01% of Staphylococcus aureus	60.07% of PM2.5
HI-NANO can remove more than 92.6% of HINI in 2 hours.	HI-NANO can sterilize more than 88.54% of E. coli in 2 hours.	HI-NANO can sterilize more than 74.01% of Staphylococcus aureus in 2 hours.	HI-NANO can effective remove more than 60.07% of PM2.5 in 2 hours.

\* The test result comes from the test of Hisense split air conditioner (model:AST-12UW4RMRCF) by SGS in a 30m³ test chamber.

## PE-QFA-CDH Option

PE-QFA-CD is standard panel.  
PE-QFA-CDH is an optional panel. And this panel is standard with HI-NANO.  
So that HI-NANO can be well installed before shipment.



## Fresh Air Intake

The fresh air intake can introduce the outdoor fresh air into the room to improve the indoor air quality.

\* The fresh air volume cannot exceed 20% of total design air volume.

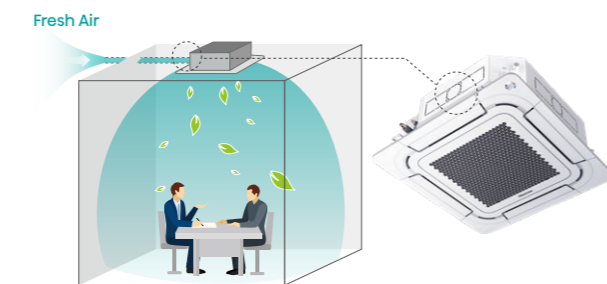

## Ag<sup>+</sup> Healthy Filter

The Ag<sup>+</sup> healthy filter is equipped as standard, which can effectively inhibit the breeding of bacteria and viruses, thereby ensuring a healthy room air supply.

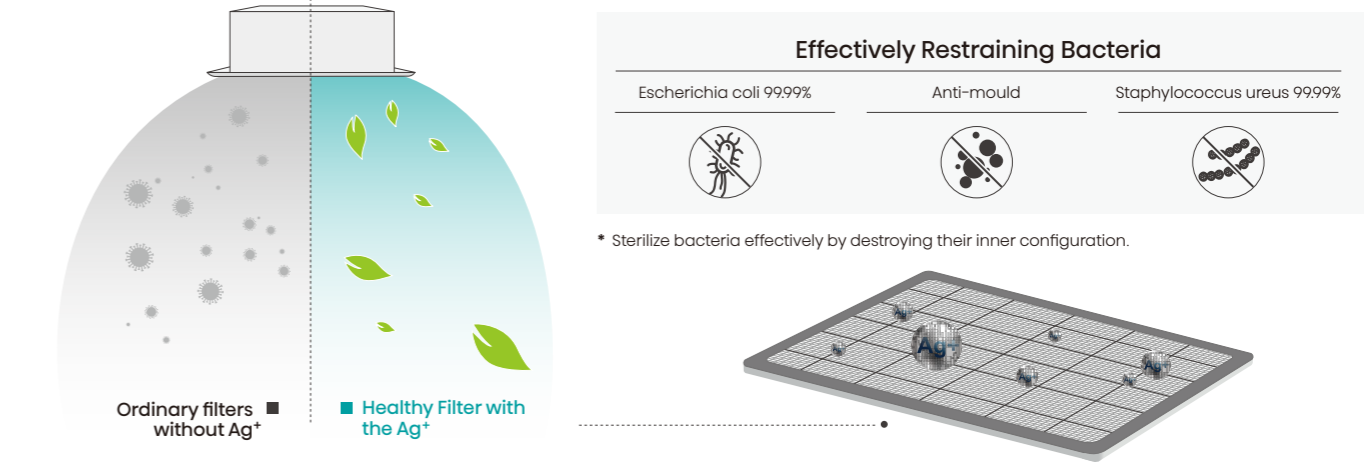

## Filter Easy Cleaning

The filter is water-washable. After the cleaning of filter, the grille can be installed in any direction. The grille has no need to be adjusted in multiple units project thanks to special pattern design of hexagons and triangles.

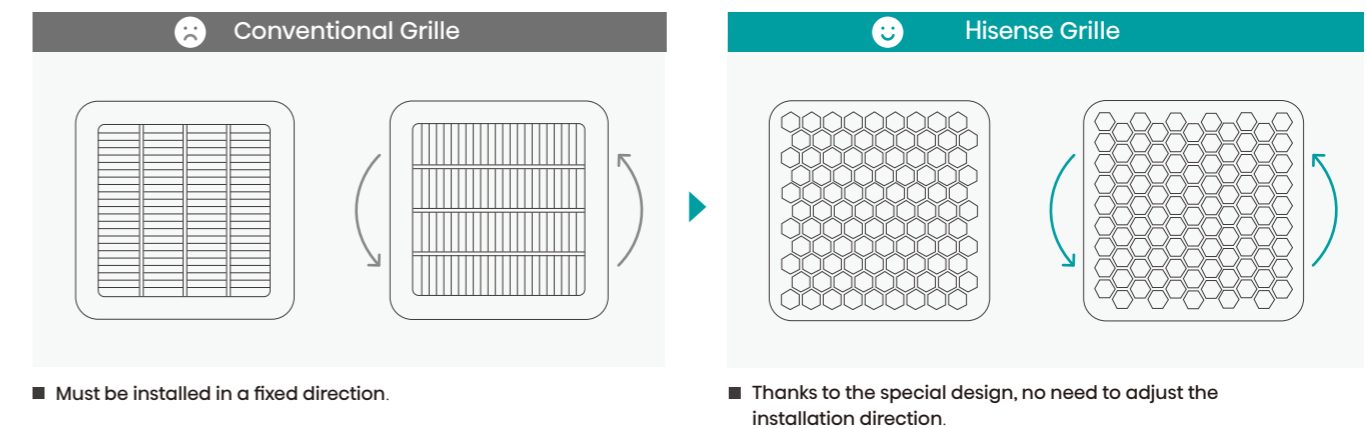

## Hidden Display

Different from traditional light display, temperature on the LED display panel is easily visible; the display is hidden in OFF mode, and the design is simple and neat.

### LED ON



### LED OFF



## Error Code Display

We can identify the Error code through the panel display. When there is an error, E will light up and the error code will flash. It is easier for us to troubleshoot.

### Example: Error code E22

22°C or 22 fault can be distinguished.



## Humidity Control

The humidity sensor is standard for Cassette. In dry mode, the room relative humidity can be displayed by the 888 LED display panel or by the wired controller YXE-E01U(E).

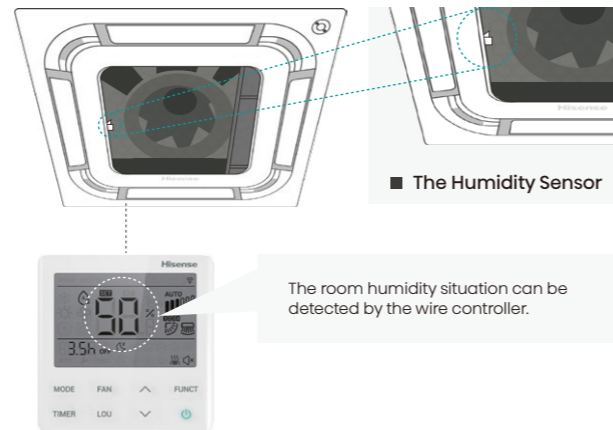

## High Sense Panel

The space dislocation design of triangular and hexagonal can achieve the wind-breaking low noise. And this high sense design can match any decoration style.

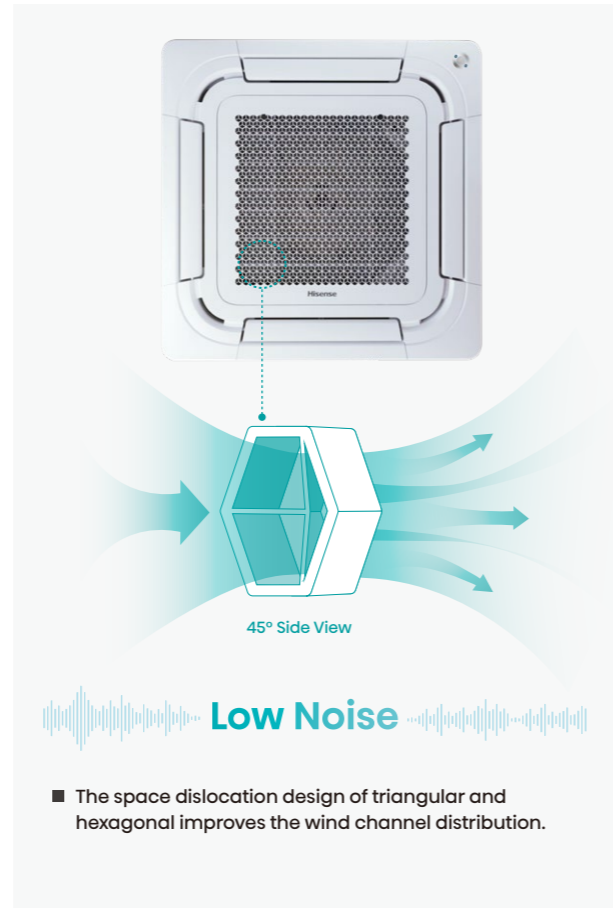

## High Ceiling

When the ceiling is high, the unit parameters can be set by the wired controller to compensate the installation height. Even in spaces with high ceilings, a comfortable airflow is carried down to the floor level.

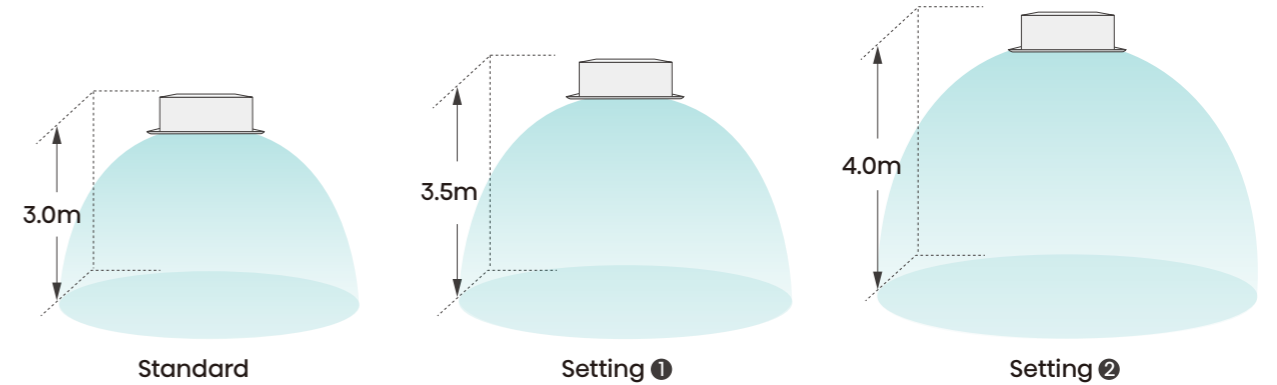

## Compact Design

The compact design with body thickness of only 236mm reduces the ceiling height. The compact design makes the most slim design for high efficiency lineup in class.

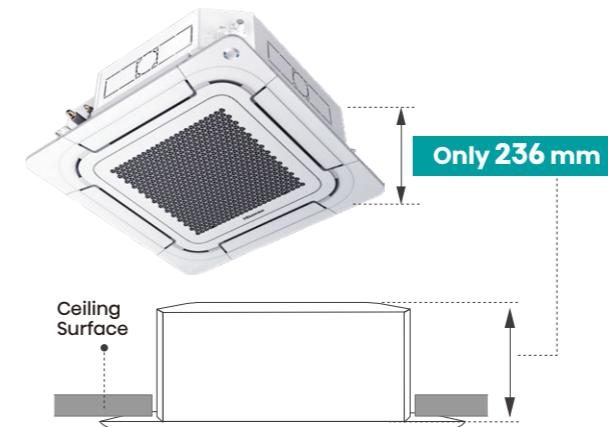

## Inner High Lift Pump

The maximum lift of Hisense high lift pump components can be as high as 1200mm.

\* In order to ensure smooth drainage in long-term operation, the recommended drainage height is <math>\leq 800\text{mm}</math>.

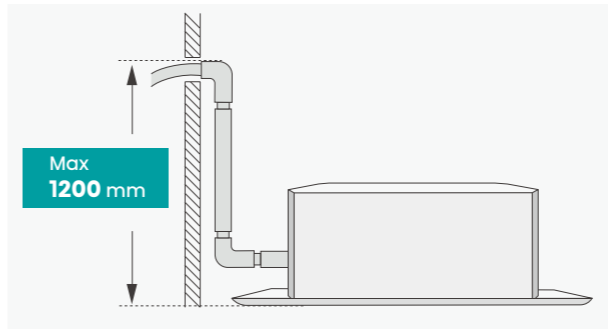

## Branch Discharge Option

In irregular room layouts, branch discharge could come in handy by extending air distribution area to the most awkward corners without additional indoor units.

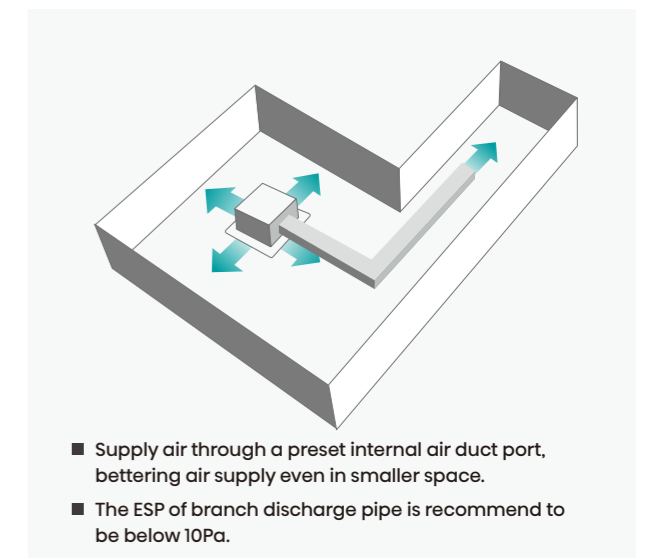

# SLIM DUCT



## Slim Design

Slim duct unit, from 2.5kW to 7.0kW, have the height of only 190mm.

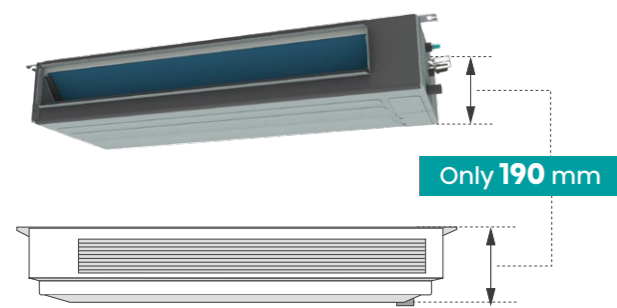

MODEL	W×H×D (mm)
9K	910×190×447
12K	910×190×447
14K	1180×190×447
18K	1180×190×447
24K	1180×190×447

## Inner High Lift Pump

The maximum lift of Hisense high lift pump components can be as high as 1200mm.

\* In order to ensure smooth drainage in long-term operation, the recommended drainage height is ≤800mm.

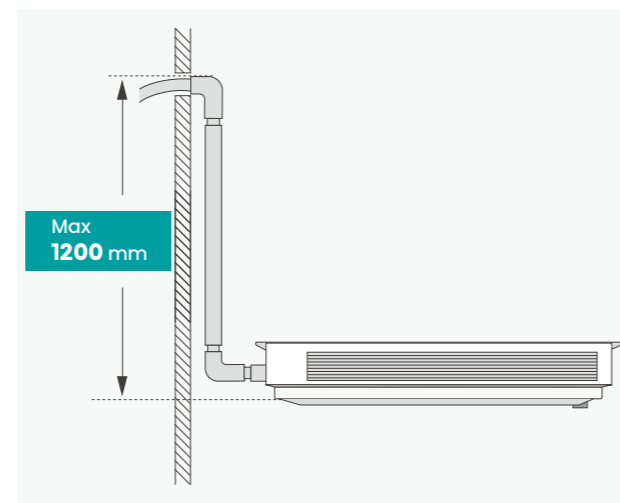

## Float Switch

The float switch can ensure the water always under the safety level, even if the pump failed or the drain is blocked. This is double insurance of no water leakage disaster. Hisense duct units are all standard with float switch. The drain pan of Hisense is big enough for containing all the water returned from the drain pipe in suddenly power off.

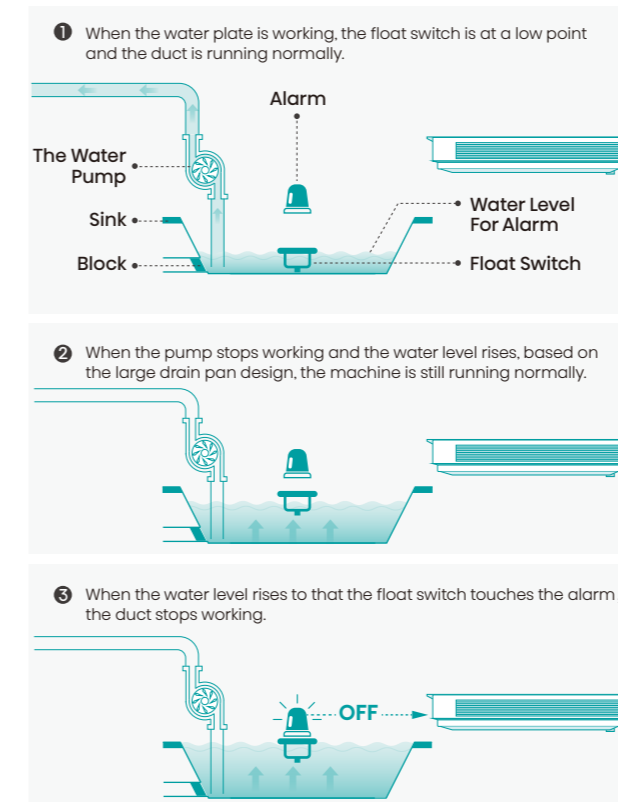

## 1Pa Adjustment

It is possible to adjust the ESP setting via wired controller. And the precision of 1 Pa can give the most accurate ESP setting in class.

\* YXE-C01U1(E) is recommended to set the ESP parameter.(Parameter setting 17→10→from 1 to 250)  
Warning: The slim duct with the capacity of 7.0kW(24K Btu/h) has the max ESP 40Pa. If we have to install the duct unit with a long duct, we have to choose the MSP duct of 7.0kW(24K Btu/h).

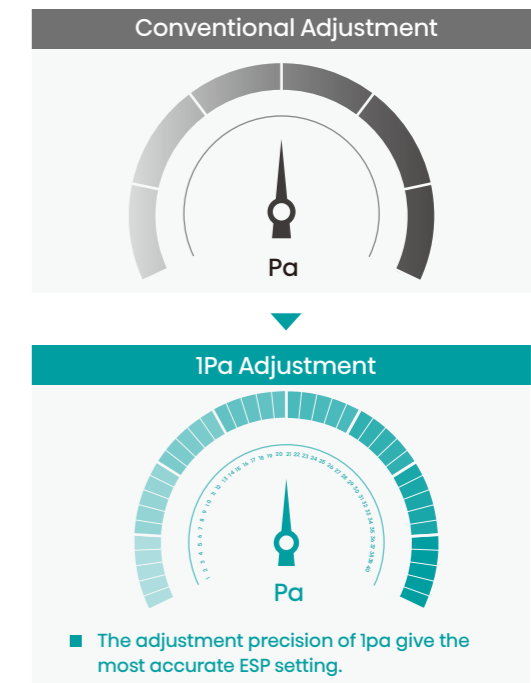

## Easy Installation

Air suction direction can be altered from rear suction to bottom suction. We can install it for free use or for connecting to suction grilles.

\* It is recommended to choose the rear suction because the noise from the rear suction is about 5 dB(A) lower than the bottom suction.

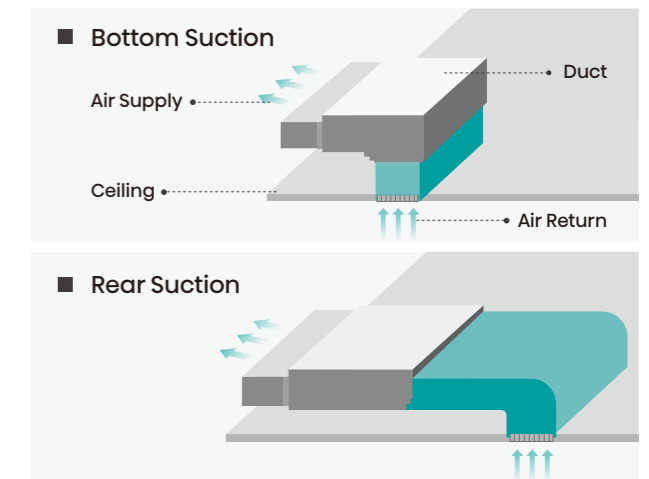

## Filter

Hisense Duct units are all standard with nylon filter. The long-life filter can reduce the replacement and cleaning times. The filter is washable so that the dust can be easily washed off from the filter.

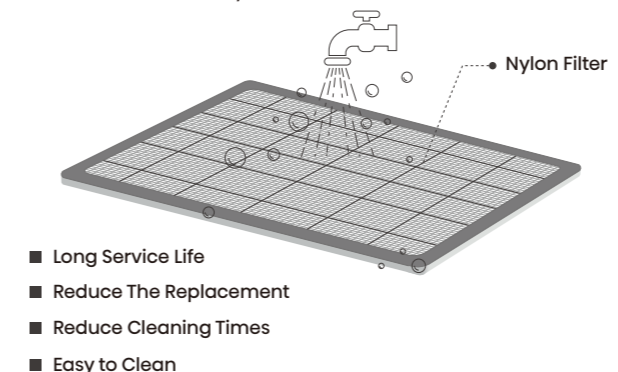

# MSP DUCT

## Slim Design

It is one of the most compact bodies in the MSP range. Installation is possible even in buildings with narrow ceiling and small spaces.

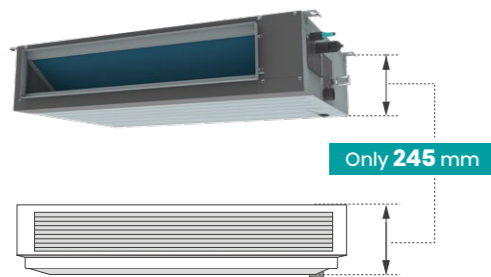

MODEL	W×H×D (mm)
14K	800×245×700
18K	800×245×700
21K	1100×245×700
24K	1100×245×700
30K	1100×245×700
36K	1400×245×700
42K	1400×245×700
48K	1400×245×700

## Inner High Lift Pump

The maximum lift of Hisense high lift pump components can be as high as 1200mm.

\* In order to ensure smooth drainage in long-term operation, the recommended drainage height is ≤800mm.

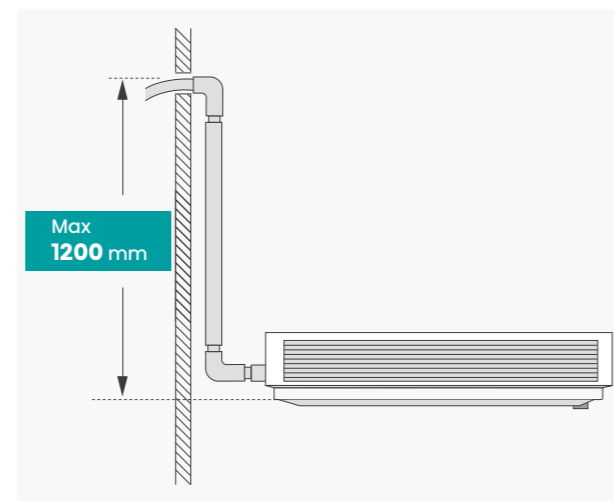

## Float Switch

The float switch can ensure the water always under the safety level, even if the pump failed or the drain is blocked. This is double insurance of no water leakage disaster. Hisense duct units are all standard with float switch. The drain pan of Hisense is big enough for containing all the water returned from the drain pipe in suddenly power off.

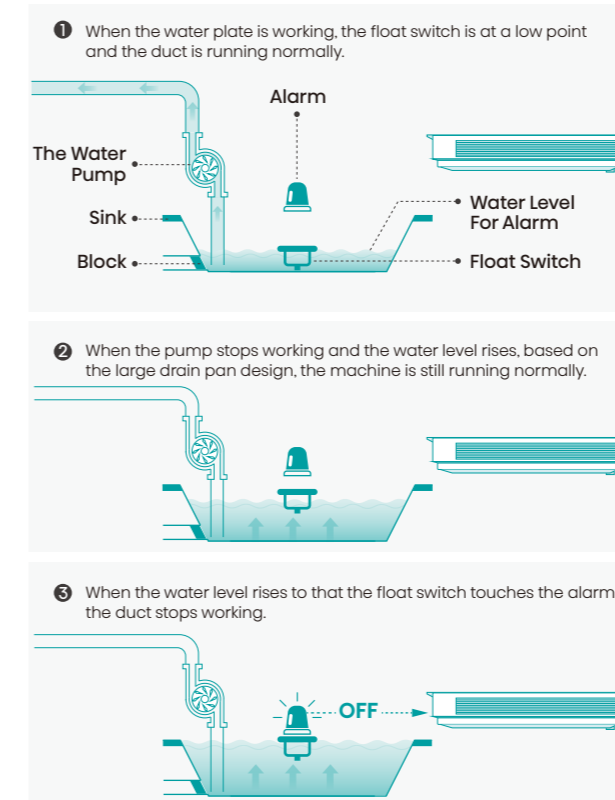

## 1Pa Adjustment

It is possible to adjust the ESP setting via wired controller. And the precision of 1 Pa can give the most accurate ESP setting in class.

\* YXE-C01U1(E) is recommended to set the ESP parameter. (Parameter setting 17 → 10 → from 1 to 250)  
Warning: The slim duct with the capacity of 70kW(24K Btu/h) has the max ESP 40Pa. If we have to install the duct unit with a long duct, we have to choose the MSP duct of 70kW(24K Btu/h).

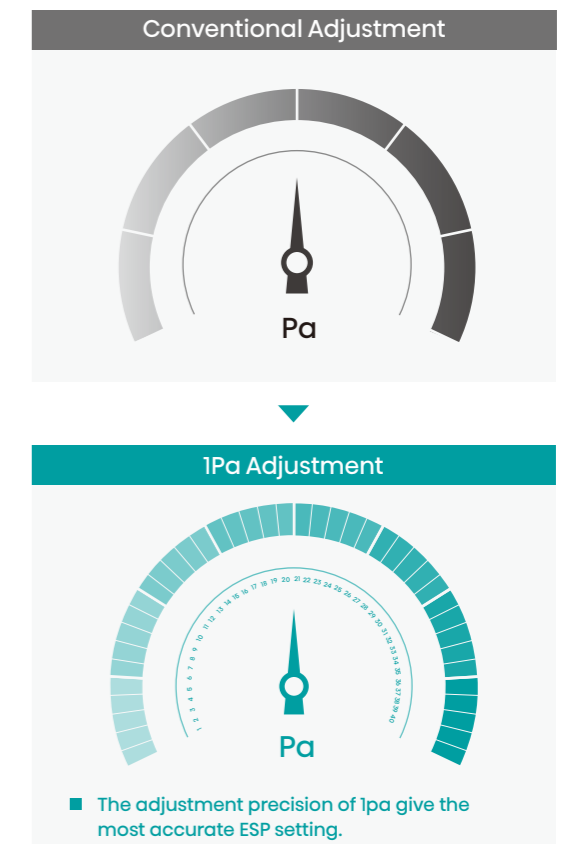

## Filter

Hisense Duct units are all standard with nylon filter. The long-life filter can reduce the replacement and cleaning times. The filter is washable so that the dust can be easily washed off from the filter.

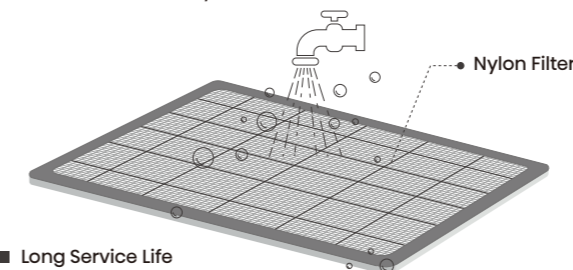

- Long Service Life
- Reduce The Replacement
- Reduce Cleaning Times
- Easy to Clean

## ESP Up to 150Pa

The external static pressure of ESP Duct unit up to a maximum of 150Pa makes it applicable for a wide range of building types.

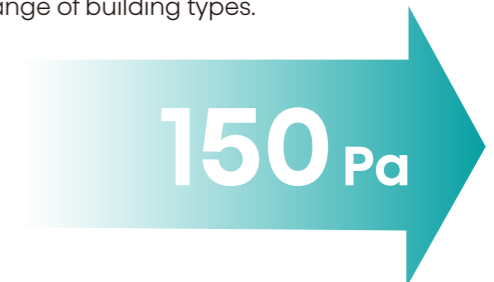

Set to high static pressure for advanced needs such as when using dampers and long ducts.

# HSP DUCT

## Slim Design

It is one of the most compact bodies in the HSP range. Installation is possible even in buildings with narrow ceiling and small spaces.

■ 36K 42K 48K

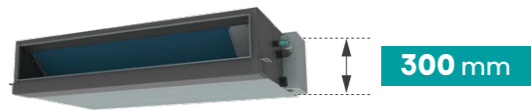

■ 75K 85K

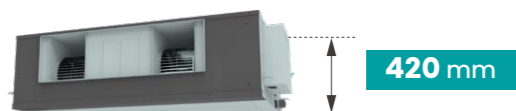

MODEL	W×H×D (mm)
36K	1400×300×800
42K	1400×300×800
48K	1400×300×800
75K	1400×420×858
85K	1400×420×858

## Inner High Lift Pump

The maximum lift of Hisense high lift pump components can be as high as 1200mm.

\* In order to ensure smooth drainage in long-term operation, the recommended drainage height is ≤800mm.

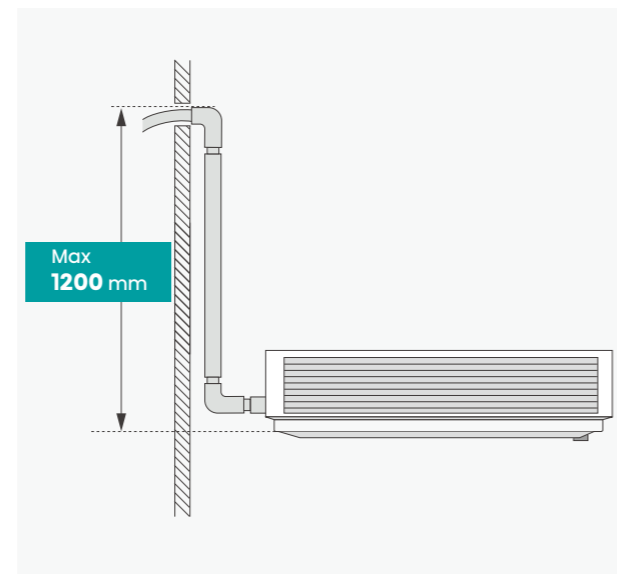

## Float Switch

The float switch can ensure the water always under the safety level, even if the pump failed or the drain is blocked. This is double insurance of no water leakage disaster. Hisense duct units are all standard with float switch. The drain pan of Hisense is big enough for containing all the water returned from the drain pipe in suddenly power off.

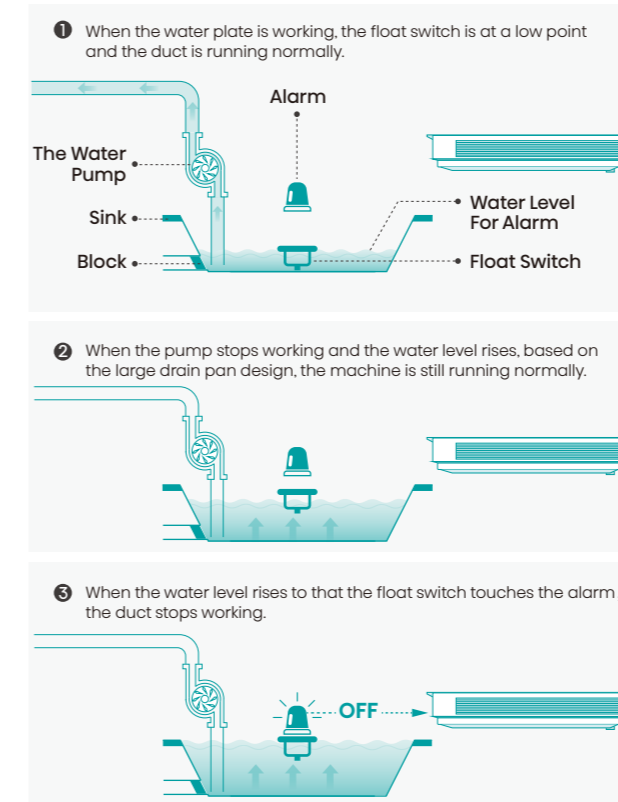

## Filter

Hisense Duct units are all standard with nylon filter. The long-life filter can reduce the replacement and cleaning times. The filter is washable so that the dust can be easily washed off from the filter.

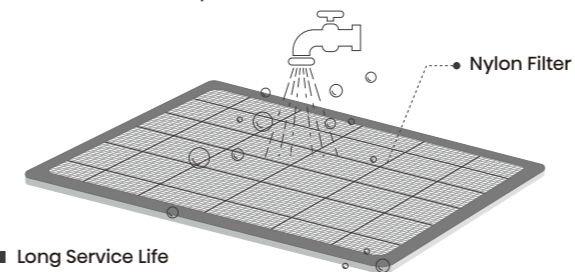

- Long Service Life
- Reduce The Replacement
- Reduce Cleaning Times
- Easy to Clean

## 1Pa Adjustment

It is possible to adjust the ESP setting via wired controller. And the precision of 1 Pa can give the most accurate ESP setting in class.

\* YXE-C01U1(E) is recommended to set the ESP parameter. (Parameter setting 17→10→from 1 to 250)  
Warning: The slim duct with the capacity of 70kW(24K Btu/h) has the max ESP 40Pa. If we have to install the duct unit with a long duct, we have to choose the MSP duct of 70kW(24K Btu/h).

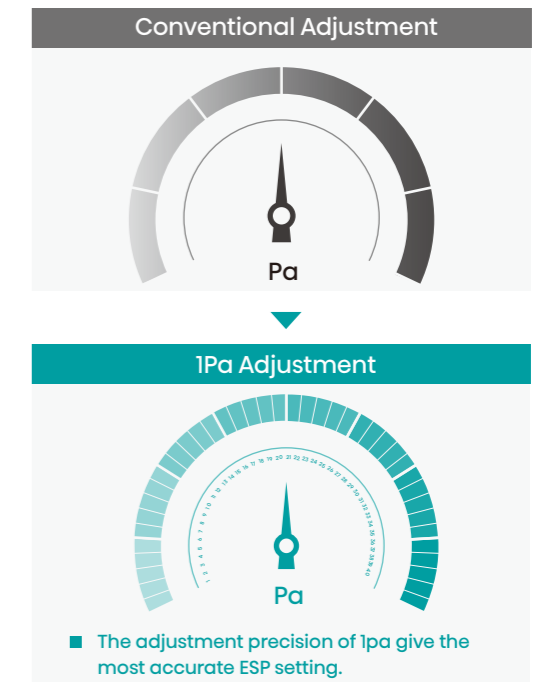

## ESP Up to 250Pa

It can meet different duct requirement and high efficiency and high wind resistance filter requirement.



Set to high static pressure for advanced needs such as when using dampers and long ducts.

MODEL	Max Static Pressure (Pa)
300mm	200
420mm	250

# CEILING SUSPENDED



## Flexible Installation

Ceiling suspended unit adopts a special structure which can meet seat, lifting and inclined installation mode. And piping can be arranged in four directions, left, right, rear and bottom.

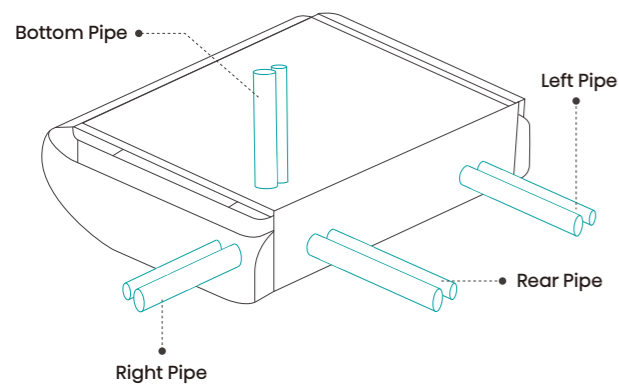

4-direction refrigerant piping offers greater installation flexibility.

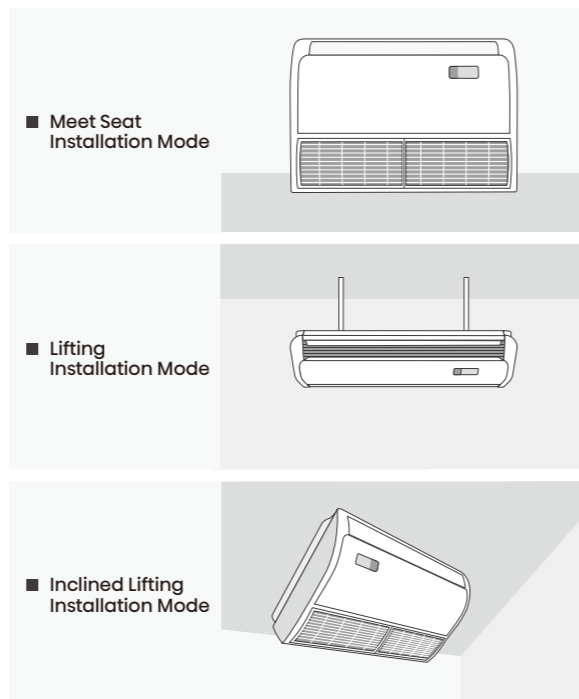

## Sleek Smooth Design

Shiny white cover panel of the unit has an streamlined elegant aesthetic. The bolts and nuts used to secure the unit onto wall or ceiling are designed to be concealed in the unit for a sleek room interior look.

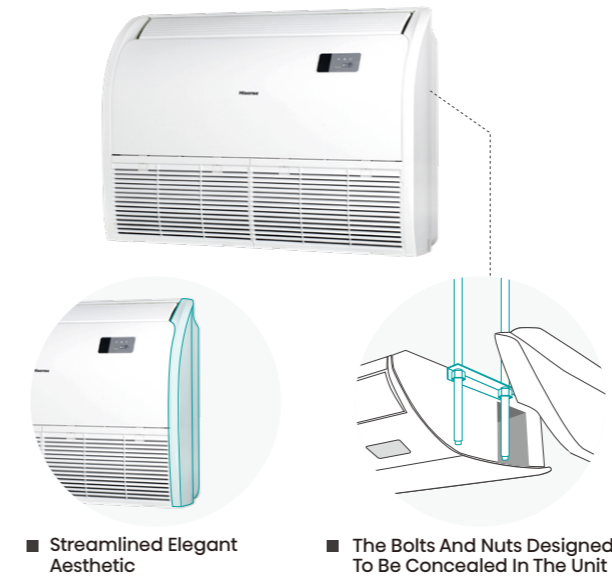

Streamlined Elegant Aesthetic  
The Bolts And Nuts Designed To Be Concealed In The Unit

## Easy Installation

Without the need to access the internal parts, just opening the side panels can adjust the ceiling or wall mounting height. Service manholes are unnecessary due to easy design of electric box.

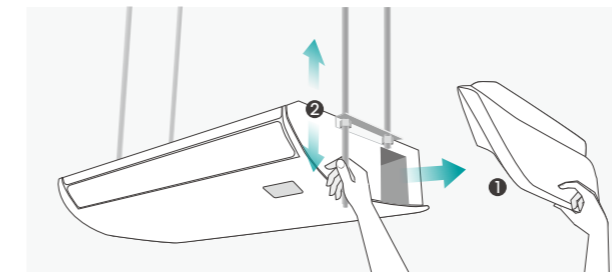

1 Opening The Side Panels  
2 Adjust The Ceiling Or Wall Mounting Height

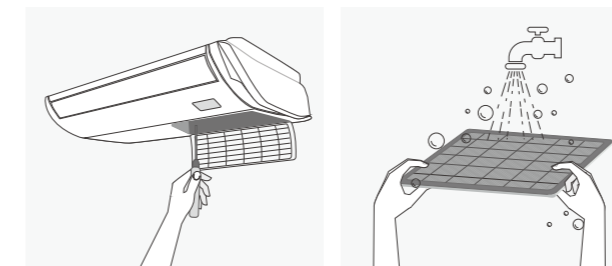

Easy To Repair  
Filter Easy To Clean

## 4D Airflow

The horizontal and vertical airflow can provide better comfort. Up to 90° airflow in horizontal direction. Up to 130° airflow in vertical direction.

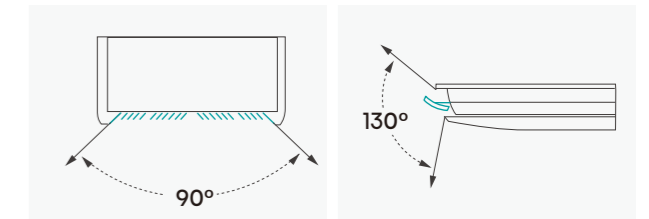

## ON/OFF Button

We can start the unit by pressing the emergency use bottom when the controller is not available. And it is very convenient for floor seated installation.

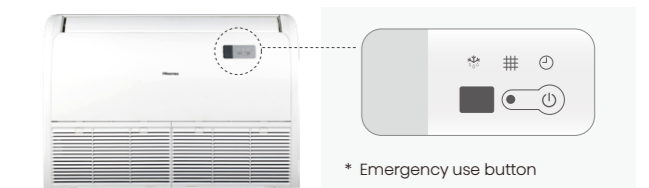

\* Emergency use button

## Airflow 15m Distance

The airflow can be up to 15m distance. People can enjoy comfortable airflow even in large spaces.



Large Air Volume And Fast Cooling

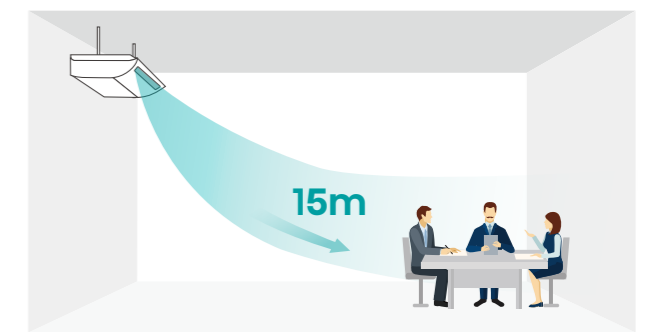

Long-distance Air Supply Up To 15m

# CONSOLE



## Dual Vane Design

The unique dual vane can be completely sealed when the unit is off, and can rotate independently when the unit is on. The console unit can give a comfortable airflow distribution.

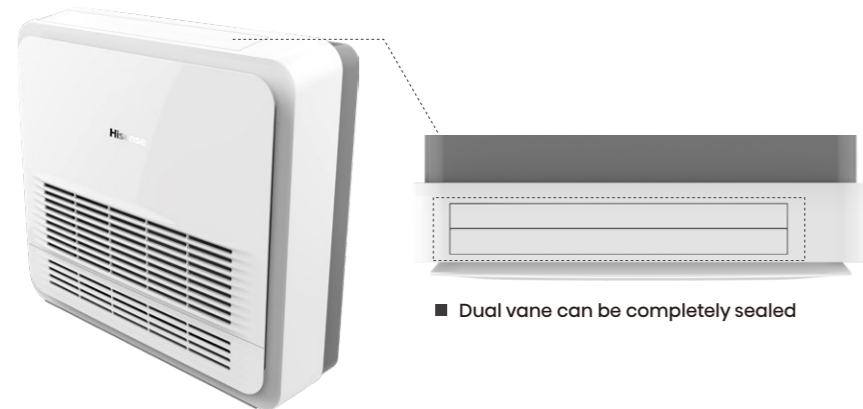

■ Dual vane can be completely sealed

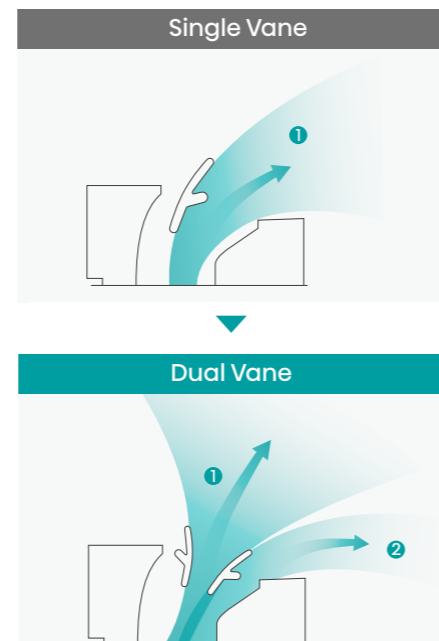

## Various Airflow

Various airflow of top air-out, bottom air-out, top & bottom air-out make the air distribution and temperature more comfortable.

Switch Setting	Air Flow	
	Cooling	Heating

### Changing air flow DIP switch

Change the air flow DIP switch to ON to limit the air flow direction.

1. Remove the front grille.
2. Switch the DIP switch on right side of the panel to ON.

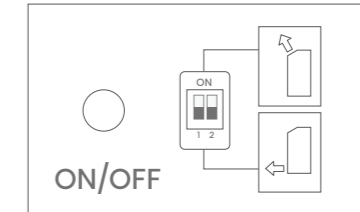

Note: Air conditioner automatically decides the appropriate blowing pattern.

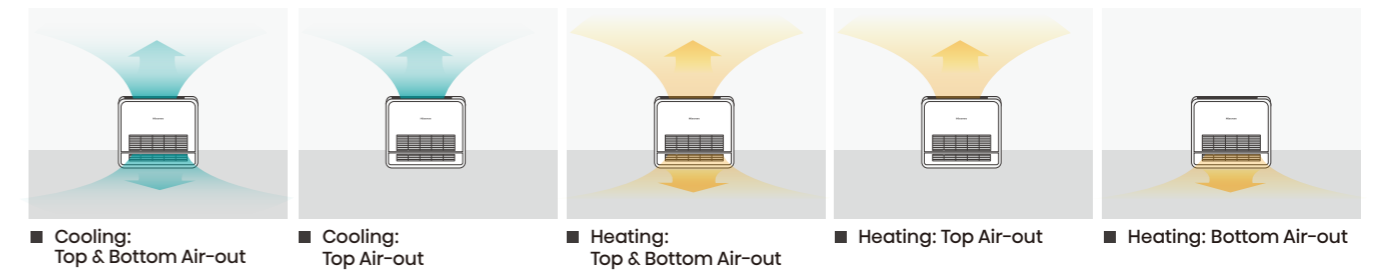

■ Cooling: Top & Bottom Air-out

■ Cooling: Top Air-out

■ Heating: Top & Bottom Air-out

■ Heating: Top Air-out

■ Heating: Bottom Air-out

## HI-NANO

HI-NANO can effectively prevent bacteria. Release a large number ion stream, kill and remove bacteria and viruses quickly through the recycle indoor air.

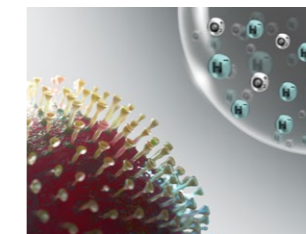

■ HI-NANO reliably reaches pollutants.

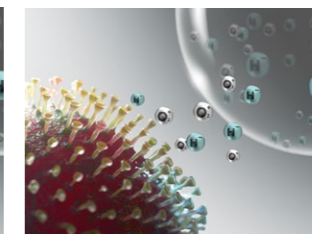

■ Hydroxyl radicals denature pollutants' proteins.

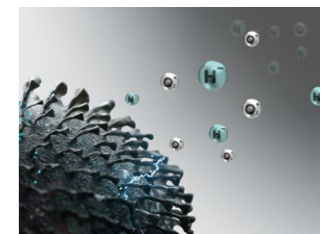

■ Pollutants activity is inhibited.

HI-NANO Sterilization Type			
92.6% of H1N1	88.54% of E. coli	74.01% of Staphylococcus aureus	60.07% of PM2.5
HI-NANO can remove more than 92.6% of H1N1 in 2 hours.	HI-NANO can sterilize more than 88.54% of E. coli in 2 hours.	HI-NANO can sterilize more than 74.01% of Staphylococcus aureus in 2 hours.	HI-NANO can effective remove more than 60.07% of PM2.5 in 2 hours.

\* The test result comes from the test of Hisense split air conditioner (model:AST-12UW4RMRCF) by SGS in a 30m³ test chamber.

## Humidity Control

Anti-condensation smart control automatically works in high humidity conditions to insure no dripping from the indoor unit. The humidity of room will display in drying mode.

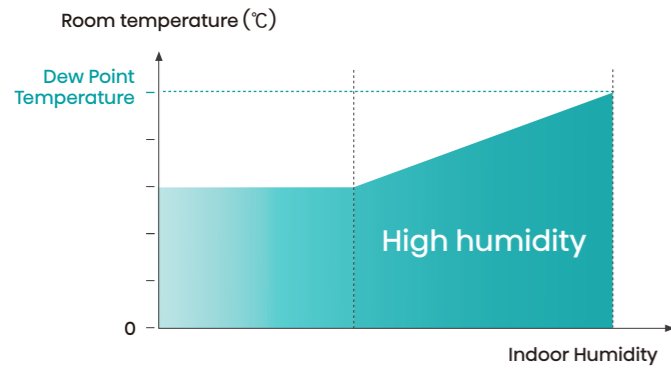

\* Automatic detection, increase the temperature of the outlet when humidity rises, avoid condensing water.

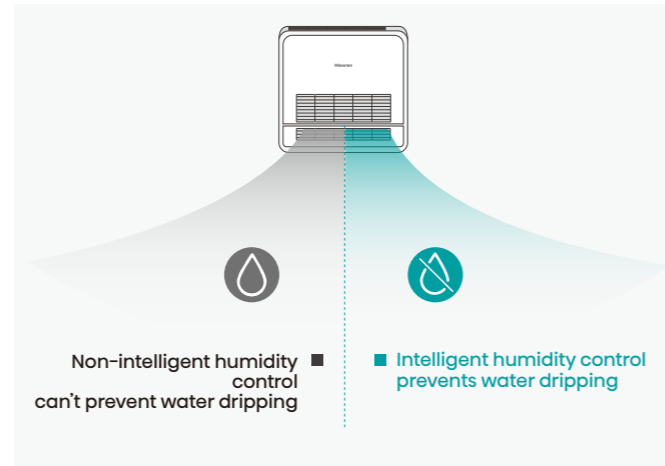

## Flexible Installation

Despite of the suitability of floor installment for console units, it is still available for wall mounting too. For a sleek look, the unit could also be installed semi-concealed or totally concealed to be used as concealed floor units.

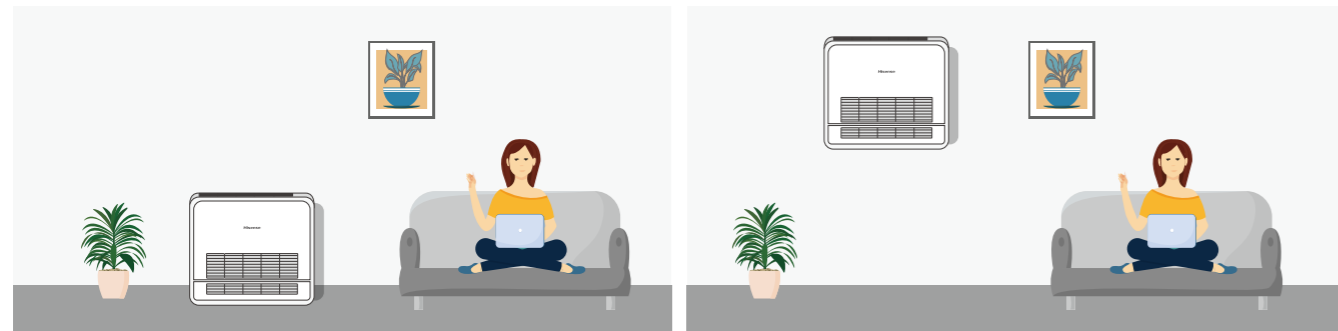

■ Standing On the Floor

■ Hanging On the Wall

## Hidden Installation

For some special project, console unit can be hidden installed or installed in a corner.

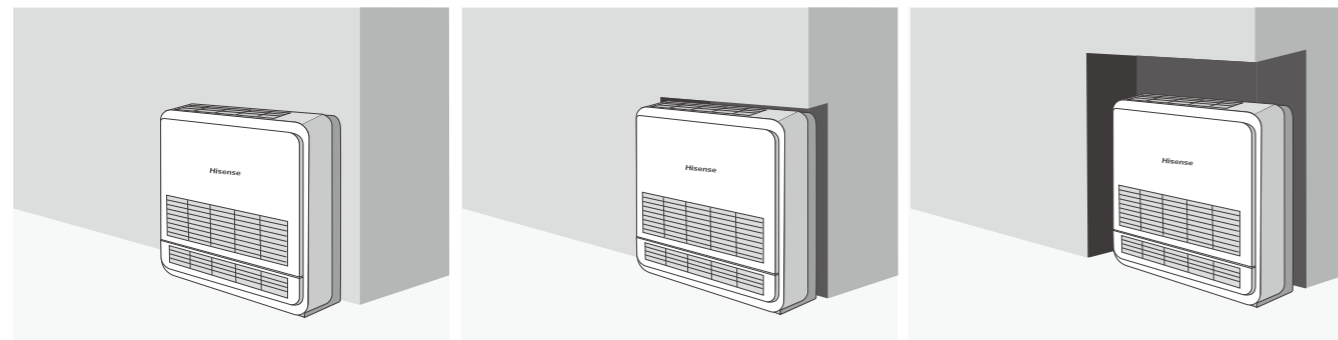

■ Direct Mounted

■ Semi-concealed Into Wall

■ Completely Concealed

## Flexible Piping

Both refrigerant and drainage pipes are freely to connect in any direction including any sides.

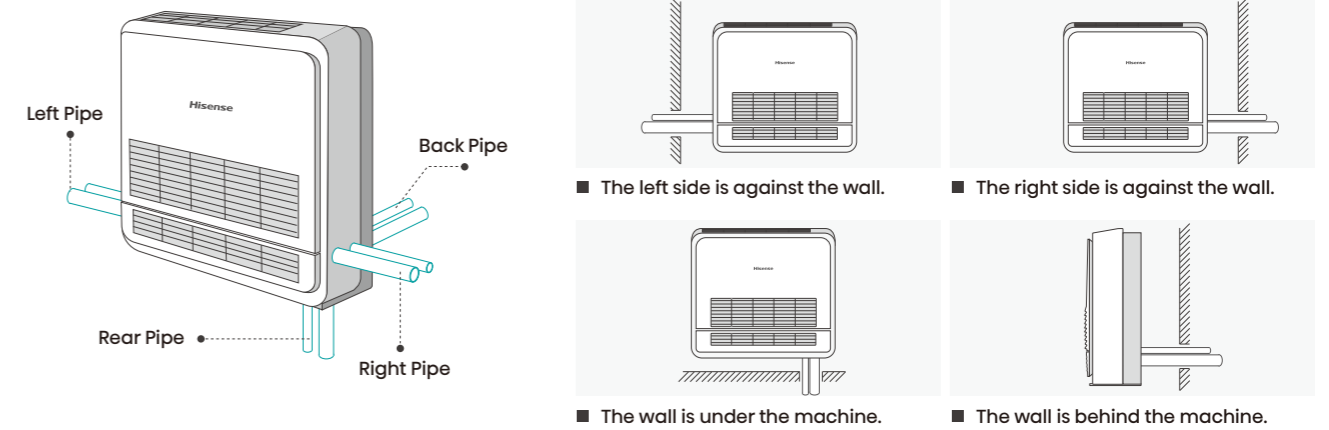

## Effective Heating

The hot airflow blowing from the bottom air-outlet can give an effective heating even with the same heating capacity, namely Foot Warming Effect.

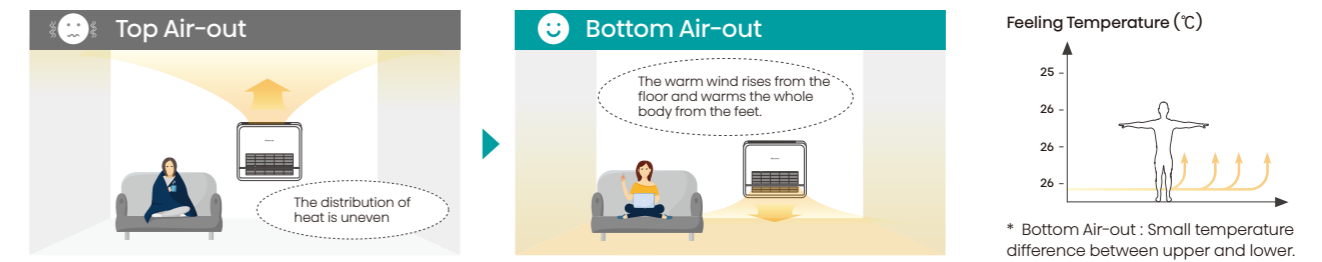

## Hidden Display

888 hidden display gives the precision of control is 0.5°C and the precision of display is 0.1°C. The humidity of room will display in drying mode.

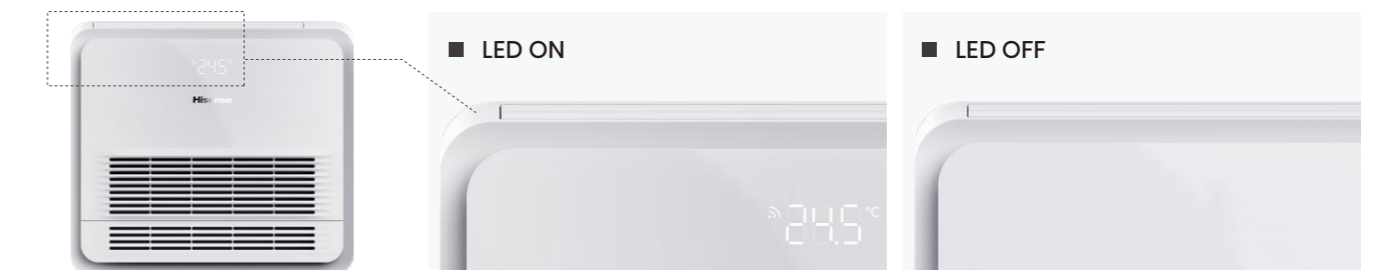

# FLOOR STANDING



## Optional Healthy Filter

There are a variety of healthy filter optional. Acticarbon Filter 4, Silver Ion Filter, 4-in-1 Filter etc.

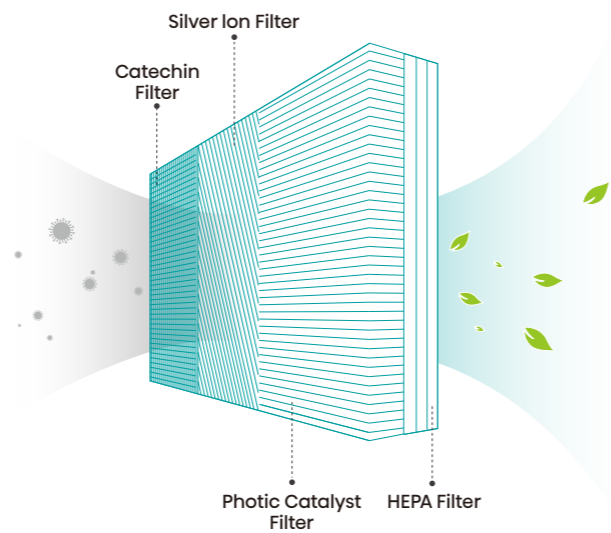

## 18m Long Distance Airflow

To meet the needs of large space, such as living room and meeting room.

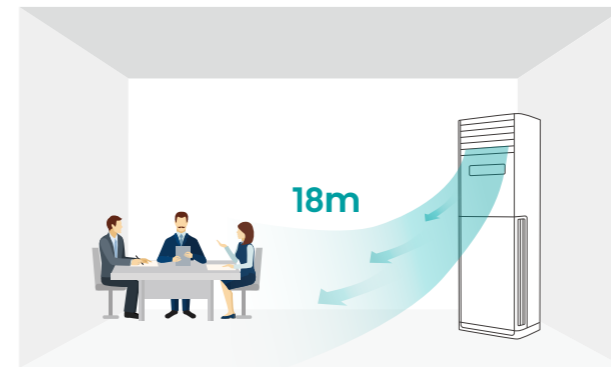

■ Long-distance air supply up to 18m.

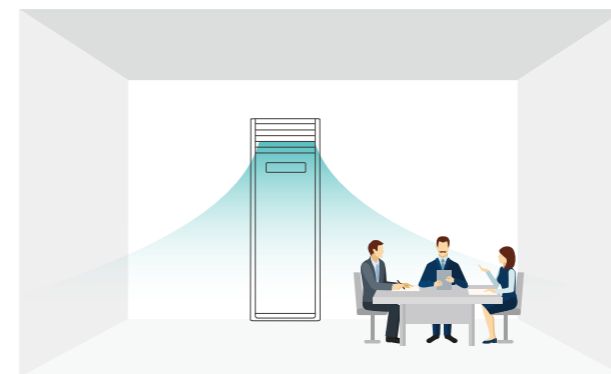

■ Large air volume and fast cooling.

## 4D Air Flow

The air louvers which can swing vertically and horizontally helps to circulate air to every corner of the room.

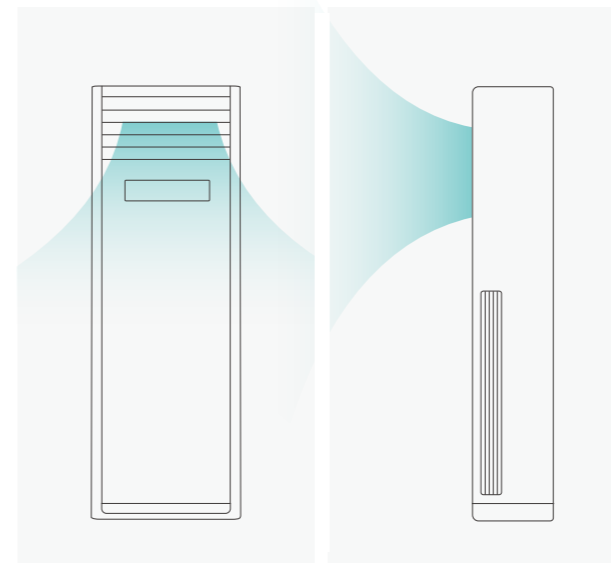

■ Right and left

■ Up and down

## Easy Clean Filter

The filter can be removed and cleaned easily.



■ Removing convenient

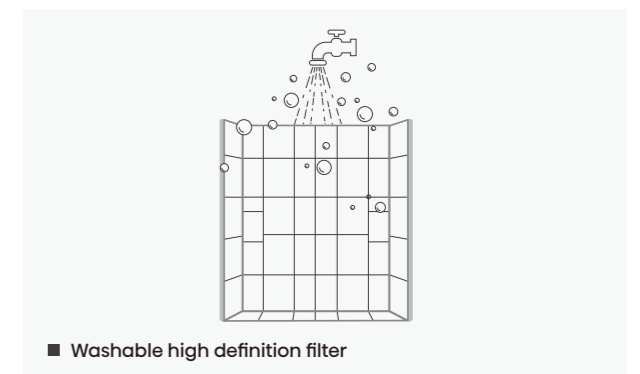

■ Washable high definition filter

## Bottom Lock

Bottom Lock can effectively prevent misoperation of settings.

1. It can lock automatically if idle beyond one minute.
2. Hold the "FAN" button to unlock.
3. The remote controller is still available when the bottom is locked.

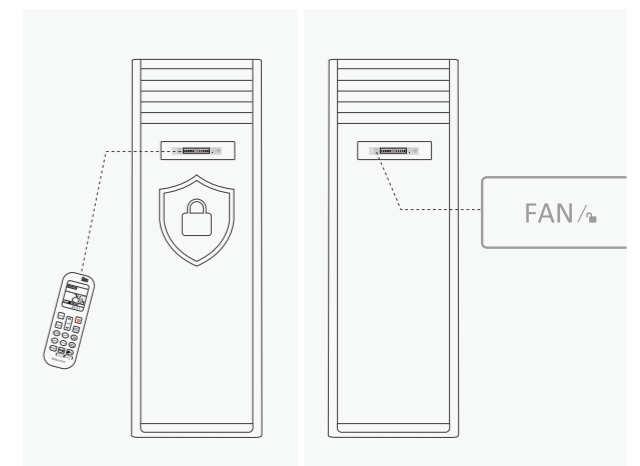

# OUTDOOR UNIT



## High Efficiency

SEER up to 7.50, A++ level;  
Average SCOP up to 4.60, A++ level  
Warmer SCOP up to 5.40, A+++ level  
EER up to 4.41W/W  
COP up to 4.50W/W



## Refrigerant Cooling Technology

Hisense uses refrigerant cooling technology to cool the electrical control box. It overcomes the poor heat dissipation and high ambient temperature issues to maintain efficient operation even at harsh environment.

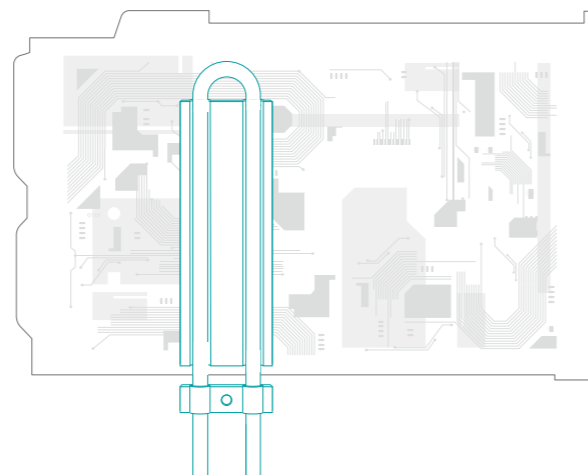

\*This Technology is Only for 75K&85K.

## Inner Stop Valve

The inner stop valve can realize 4 way piping connection (front, rear, right, down), it is more beautiful and easy installation.

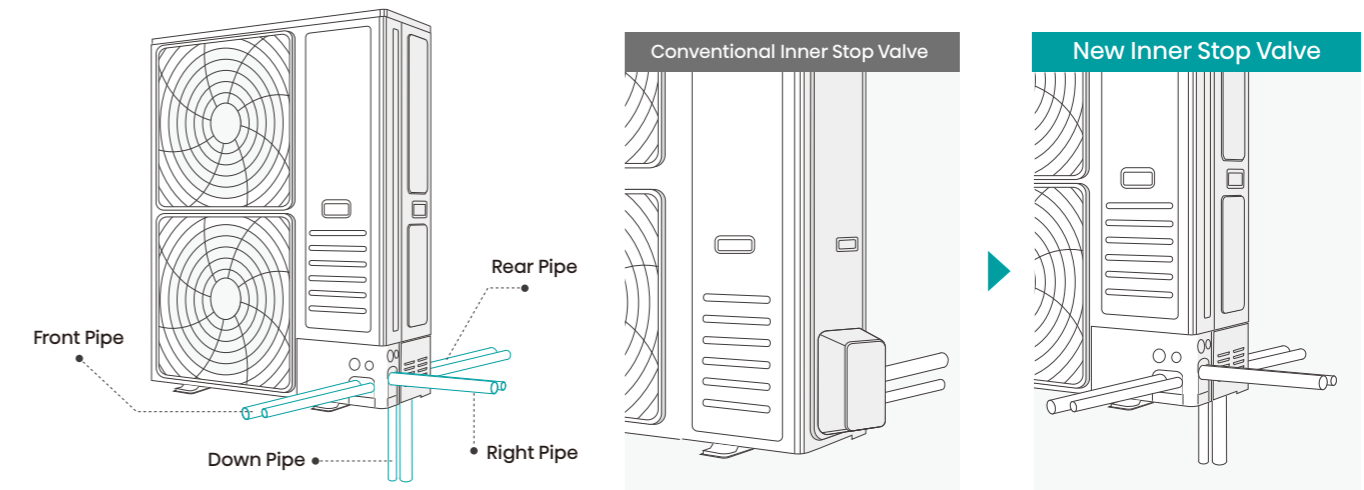

## Full DC

Hisense full DC is DC inverter compressor + DC outdoor fan motor + DC indoor fan motor + EEV. We can ensure the high efficiency not only in full load, but also in part load.

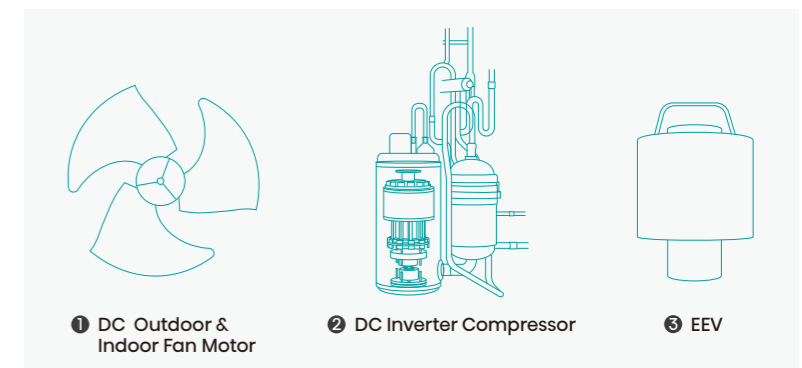
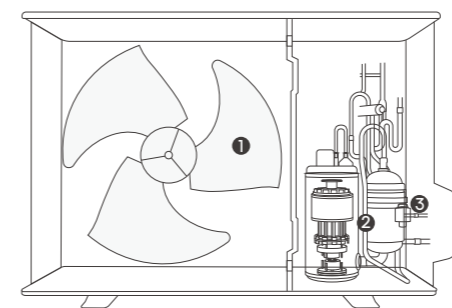

## R32

We take R32 as LCAC refrigerant because it is more environment friendly, more energy efficiency. GWP(Global Warming Potential) of R32 is 675, less than 1/3 of R410a (GWP=2088).

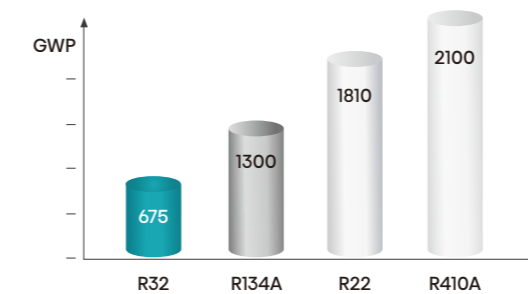

## Faster Vacuum

The double 3-way stop valves, not matter built inside or outside, can help to vacuum fast.

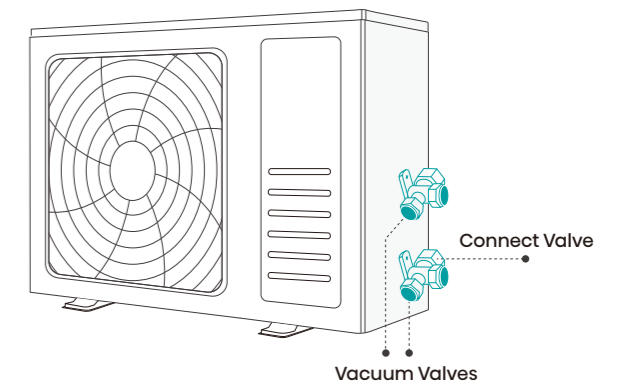

\*This Only for 24K&above.

## Wide Ambient Temperature Range

Cooling: Up to  $-15^{\circ}\text{C}$  ~  $52^{\circ}\text{C}$   
 Heating: Up to  $-20^{\circ}\text{C}$  ~  $24^{\circ}\text{C}$

\* Refer to the temperature range in specs for the specific model.

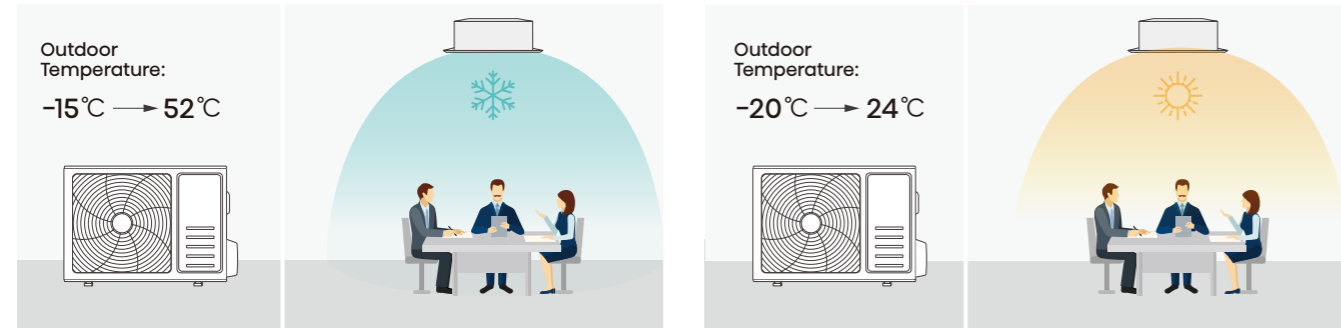

## Hi-Checker

Hi-Checker is a tool to record and monitor the operation of Hisense inverter air conditioners. It can help to provide a fast, efficient, and professional after-sale service.



## Leakage Detectives

The system will send an error code E96 and stop running when the refrigerant leakage value reach a low value, so as to ensure safety operation of the R32 air conditioners.

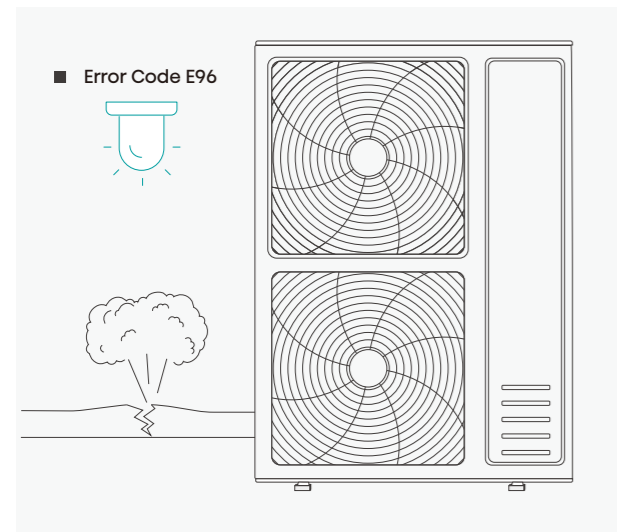

## Twin, Triple, Quadruple

In twin, triple and quadruple system, the LCAC units can be combined like a simplified mini VRF system. In this system, all indoor unit must be the same and operate at the same setting.

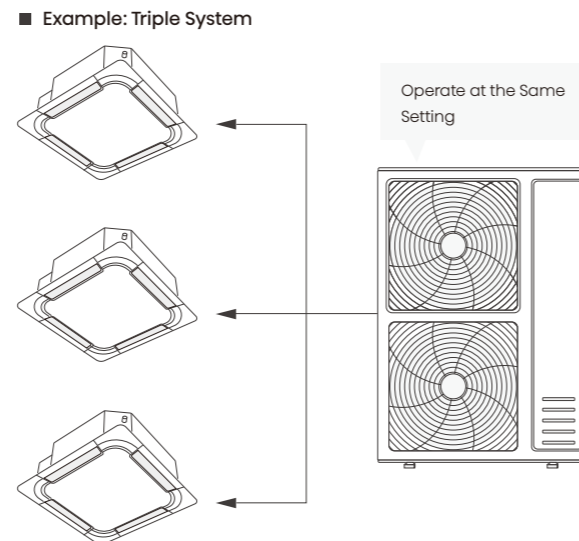

## Bottom E-Heater (Optional)

Auxiliary heating that prevents freezing of the chassis, especially in very low temperatures.

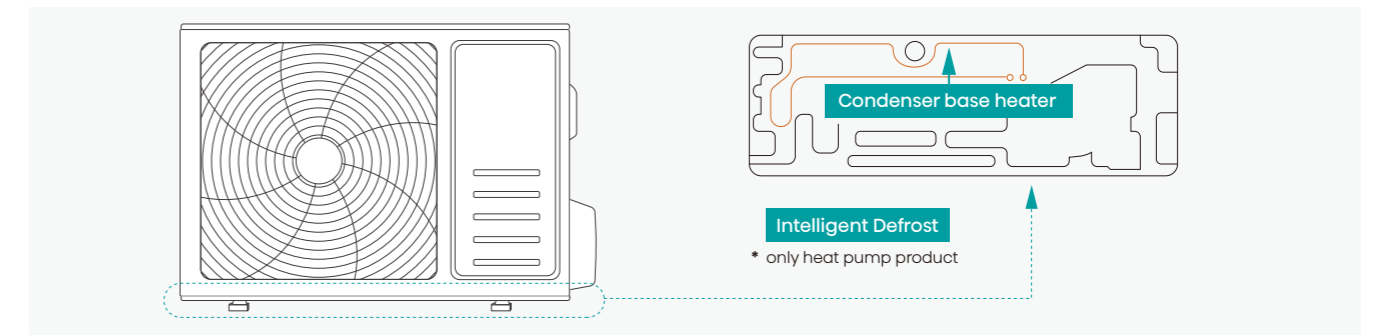

## Long Piping & Large Height Difference

With high installation flexibility, the ACs can be installed in sites with piping of up to 75m and height difference of up to 30m.

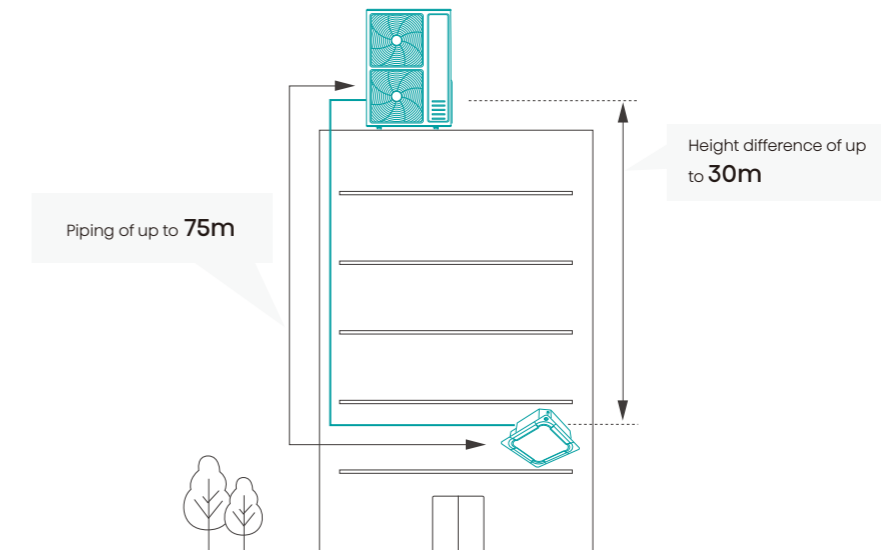

## Refrigerant Pre-charge

No additional charge of refrigerant is needed for pipe length of up to 20 meters, which accounts for 80% of LCAC project.

\* In order to ensure the durable reliability of the product, it is recommended to add the refrigerant according to the relevant instructions; the refrigerant charge is only recommended if the installation is not convenient.

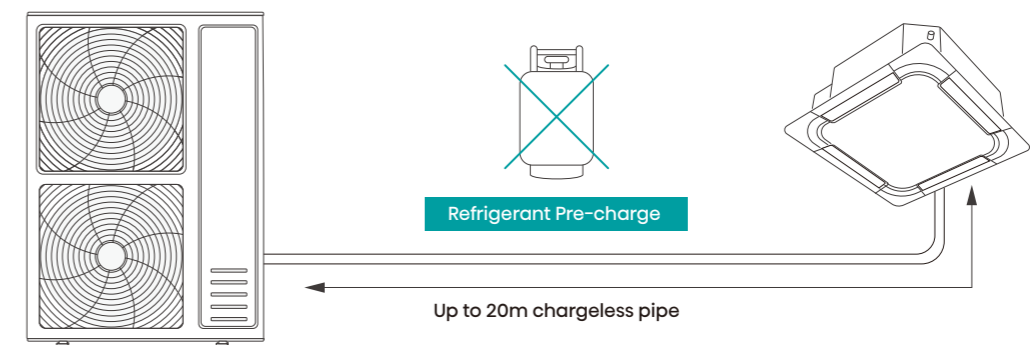

# CARBON NEUTRAL EU 2050

Climate change and environmental degradation are an existential threat to Europe and the world. To overcome these challenges, the European Green Deal will transform the EU into a modern, resource-efficient and competitive economy, ensuring:

- No net emissions of greenhouse gases by 2050.
- Economic growth decoupled from resource use.
- No person and no place left behind.

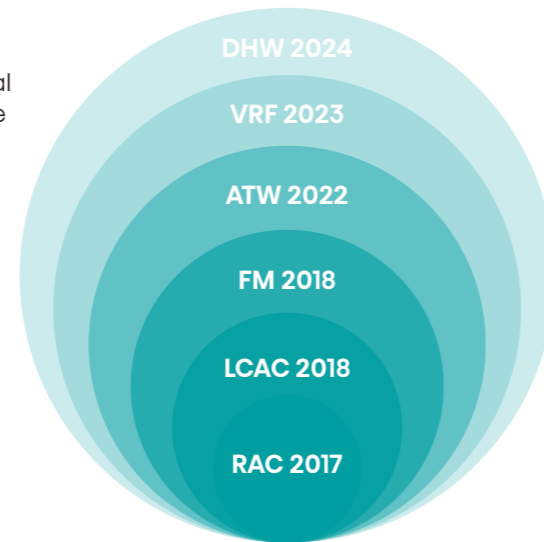

Products And Equipment		Date of prohibition
Self-contained airconditioning equipment and heat pumps, except chillers, that:	a. Single split systems, containing less than 3 kg of fluorinated greenhouse gases listed in Annex I, that contain, or whose functioning relies upon, fluorinated greenhouse gases listed in Annex I with GWP of 750 or more;	2025/1/1
	b. Split air-to-water systems of a rated capacity up to and including 12 kW containing, or whose functioning relies upon, fluorinated greenhouse gases with GWP of 150 or more, except if required to meet safety requirements at the site of operation;	2027/1/1
	c. Split air-to-air systems of a rated capacity up to and including 12 kW containing, or whose functioning relies upon, fluorinated greenhouse gases with GWP of 150 or more, except if required to meet safety requirements at the site of operation;	2029/1/1
	d. Split systems of a rated capacity up to and including 12 kW containing, or whose functioning relies upon, fluorinated greenhouse gases, except if required to meet safety requirements at the site of operation;	2035/1/1
	e. Split systems of a rated capacity of more than 12 kW containing, or whose functioning relies upon, fluorinated greenhouse gases with GWP of 750 or more, except if required to meet safety requirements at the site of operation;	2029/1/1
	f. Split systems of a rated capacity of more than 12 kW containing, or whose functioning relies upon, fluorinated greenhouse gases with GWP of 150 or more, except if required to meet safety requirements at the site of operation.	2033/1/1

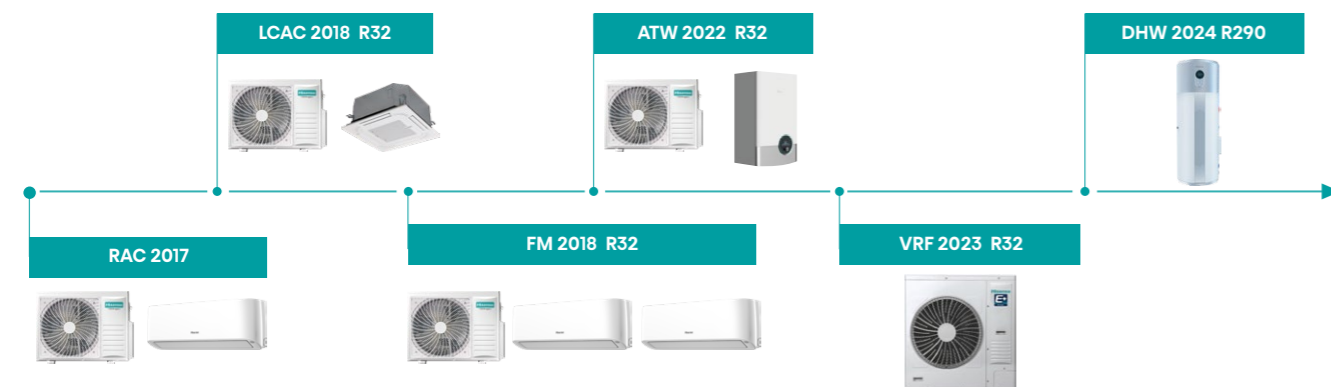

\* Hisense is trying his best to lower CO2 equivalent solutions through innovation.

## Advantages of R32

### Lower global warming potential(GWP):

32.3% of R410A  
26% of R32

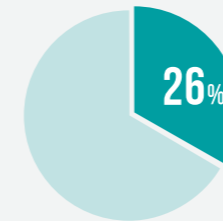

**-74%**  
Down relative global warming impact

### Lower refrigerant charged:

About 20% less than R410A with same capacity and efficiency



**20%**  
Less than R410A

Single component refrigerant, easy to recycle (R410A=50% R32 + 50% R125)



**EASY RECYCLE**

Years	Percentage to calculate the maximum quantity of hydrofluorocarbons to be placed on the market and corresponding quotas
2015	100%
2016-2017	93%
2018-2020	63%
2021-2023	45%
2024-2026	31%
2027-2029	24%
2030	21%



# DEEP COOL

## Solutions For Special Application

Hisense LCAC Turbo Inverter R32 can cool rooms down to 10°C, special application such as wine cellars, ice cream factories, flower shops, supermarkets, grain stores, food storage, food processing, food distribution, lunchrooms, vegetable processing.



- To avoid the growth of bacteria and to keep food safety: Wine cellars, ice cream factories, flower shops, broiler factories.



Food Processing



Ice Cream Factories

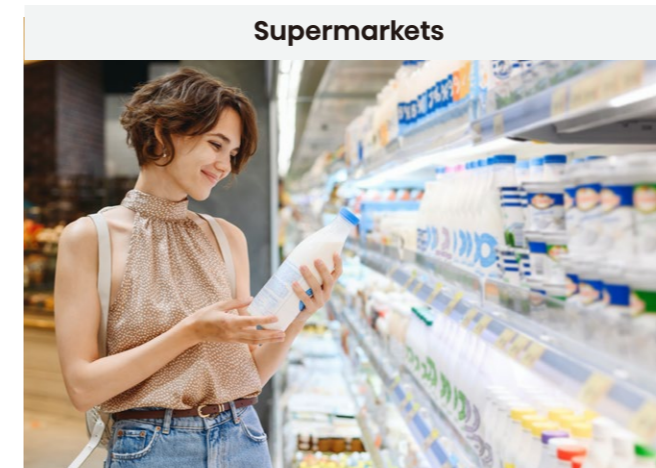

Supermarkets

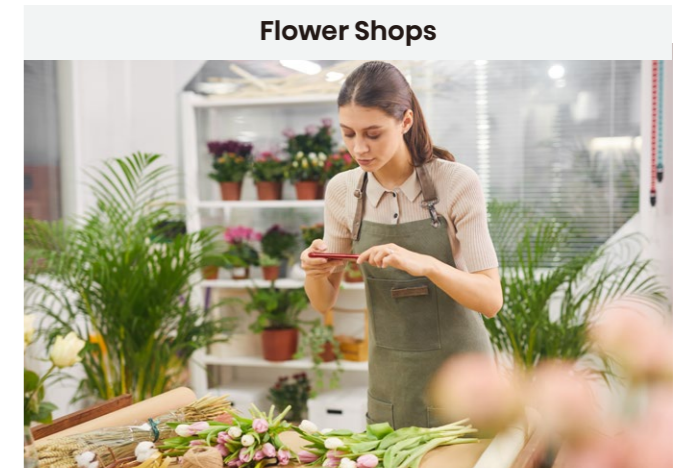

Flower Shops

Cooling Capacity		3.5kW	4.0kW	5.0kW	6.0kW	7.0kW	10.5kW	14.0kW
LCAC ODU		AUW-12U4RS8 	AUW-14U4RJ8 	AUW-18U4RJ8 	AUW-21U4RK8 	AUW-24U4RK8 	AUW-36U4RW8 AUW-36U6RW8 	AUW-48U4RW8 AUW-48U6RW8 
Compact Cassette 600×600		ACT-14UR4RCC8 ACT-18UR4RCC8						
Cassette 900×900		AUC-14UR4RJC8 AUC-18UR4RJC8	ACT-21UR4RJC8 ACT-24UR4RJC8	ACT-21UR4RJC8 ACT-24UR4RJC8	AUC-36UR4RKC8	AUC-36UR4RKC8	AUC-42UR4RKC8 AUC-48UR4RKC8	AUC-60UR4RKC8
Slim Duct 0-50Pa		ADT-14UX4RCL8 ADT-18UX4RCL8	ADT-24UX4RCL8	ADT-24UX4RCL8				
MSP Duct 0-150Pa		ADT-14UX4RGM8 ADT-18UX4RGM8	ADT-21UX4RFM8 ADT-24UX4RFM8 AUD-30UX4RFM8	ADT-21UX4RFM8 ADT-24UX4RFM8 AUD-30UX4RFM8	AUD-36UX4RQM8	AUD-36UX4RQM8	AUD-42UX4RQM8 AUD-48UX4RQM8	
HSP Duct >200Pa					AUD-36UX4REH8	AUD-36UX4REH8	AUD-42UX4REH8 AUD-48UX4REH8	AUD-60UX4REH8
Ceiling Suspended			AVT-21UR4RBB AVT-24UR4RBB	AVT-21UR4RBB AVT-24UR4RBB	AUV-36UR4RC8	AUV-36UR4RC8	AUV-42UR4RC8 AUV-48UR4RC8	AUV-60UR4RC8
Floor Standing			AUF-24UR4RCPA8	AUF-24UR4RCPA8	AUF-36UR4RMPA8	AUF-36UR4RMPA8	AUF-48UR4RMPA8	AUF-60UR4RHPA8

# TWIN, TRIPLE AND QUADRUPLE SYSTEM



With the cooperation of simplified central control system, the LCAC unit can be combined into a simplified mini VRF system. We call them twin, triple, quadruple, quintuple and sextuple system.

\* All indoor units will operate at exactly the same setting in this simplified mini VRF system.

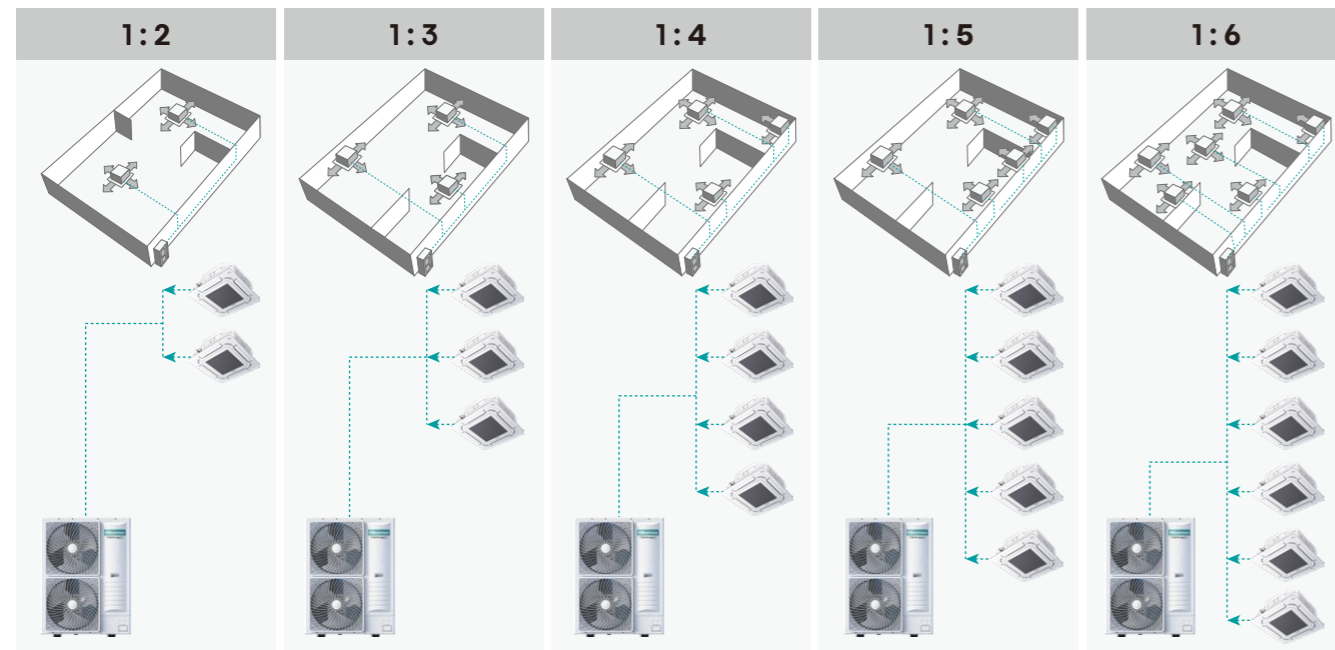

RED: Not available now, On Planning & Developing		Welding-free branch pipe	
1	Pair		/
2	Twin		FQ-3S3110(E)
3	Triple		FQ-3S3110(E)
4	Quadruple, or Double Twin		FQ-6S3110(E)
5	Quintuple		FQ-6S3110(E)
6	Sextuple, or Double Triple		FQ-6S3110(E)
D	Deep Cool		/

Turbo Inverter R32 Combination Table		Outdoor Unit AUW##8															
		09K/1P	12K/1P	14K/1P	18K/1P	21K/1P	24K/1P	36K/1P	36K/3P	42K/1P	42K/3P	48K/1P	48K/3P	60K/3P	75K/3P	85K/3P	
Compact Cassette		09K	1					3	3						6	6	
		12K		1				2	3	3	4	4	4	4	6	6	
		14K		D	1				2	2	3	3	3	3	5	5	
		18K		D		1			2	2	3	3	3	3	5	5	
Cassette		14K			1			2	2	2	2	2	2	3	4	4	
		18K			D	1		2	2	2	2	2	2	3	4	4	
		21K			D	D	1			2	2	2	2	2	3	3	
		24K			D	D		1		2	2	2	2	2	3	3	
		36K					D	D	1	1					2	2	
		42K							D	D	1	1			2	2	
		48K							D	D			1	1	1	2	2
		60K											D	D	1		
Slim Duct		09K	1					3	3						5	5	
		12K		1				2	3	3	3	3	3	4	5	5	
		14K		D	1				2	2	2	2	2	3	4	4	
		18K		D		1			2	2	2	2	2	3	4	4	
		24K			D	D		1			2	2	2	2	3	3	
MSP Duct		14K		D	1			2	2	2	2	2	2	3	4	4	
		18K		D		1		2	2	2	2	2	2	3	4	4	
		21K			D	D	1			2	2	2	2	2	3	3	
		24K			D	D		1		2	2	2	2	2	3	3	
		30K					D	D				2	2	2			
		36K					D	D	1	1					2	2	
		42K							D	D	1	1			2	2	
		48K							D	D			1	1	2	2	
		60K											D	D	1		
HSP Duct		36K				D	D	1	1						2	2	
		42K						D	D	1	1				2	2	
		48K						D	D			1	1		2	2	
		60K										D	D	1			
		75K													1		
		85K														1	
Console		09K	1					3	3						6	6	
		12K		1				2	3	3	4	4	4	4	6	6	
		14K			1				2	2	3	3	3	3	5	5	
		18K				1			2	2	3	3	3	3	5	5	
Ceiling Suspended		21K			D	D	1		2	2	2	2	2	2	3	3	
		24K			D	D		1	2	2	2	2	2	2	3	3	
		36K					D	D	1	1					2	2	
		42K							D	D	1	1			2	2	
		48K							D	D			1	1	1	2	2
		60K											D	D	1		
Floor Standing		24K			D	D		1	2	2	2	2	2	2	3	3	
		36K					D	D	1	1					2	2	
		48K							D	D			1	1	2	2	
		60K									D	D			1	1	

\* Note 1: Pair 2: Twin 3: Triple 4: Quadruple, or Double Twin 5: Quintuple 6: Sextuple, or Double Triple D: Deep Cool

# MULTIZONE

## Smart Control By Multizone

The smart control performed by our systems allows the user to achieve an optimal level of thermal and acoustic comfort as every single zone is controlled independently. We offer numerous possible combinations so that our solutions can be adapted to the needs of the user and the installation.

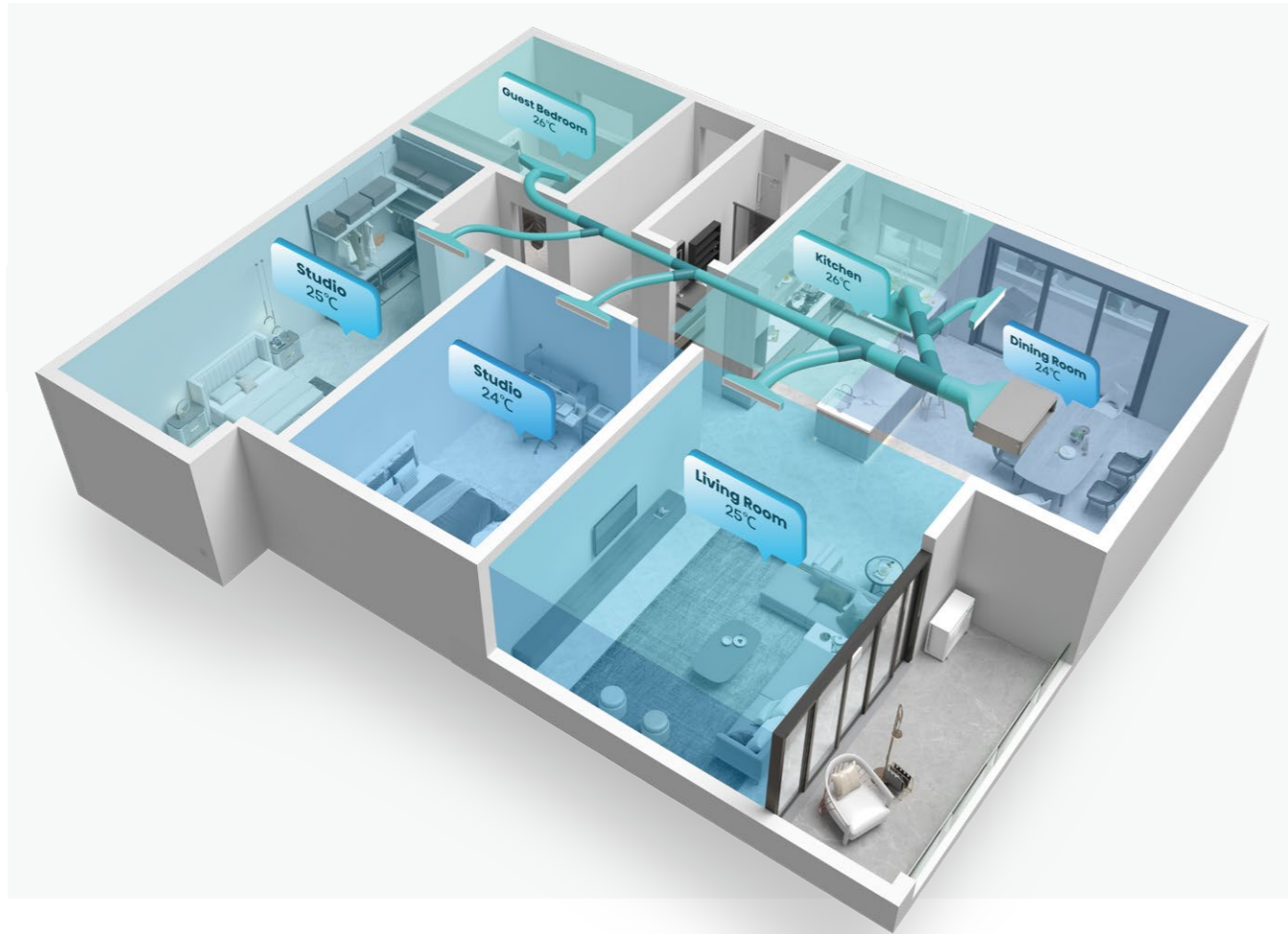

## Adapted Airzone Controller

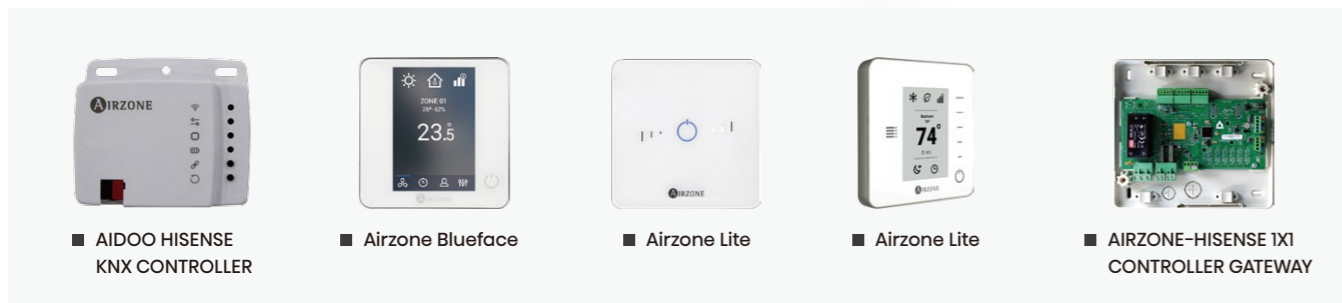

# INTELLIGENT CONTROL

## Connect Life

When the air conditioner is connected to Wi-Fi through the Hisense module, you can control the air conditioner freely through the ConnectLife app anytime and anywhere.







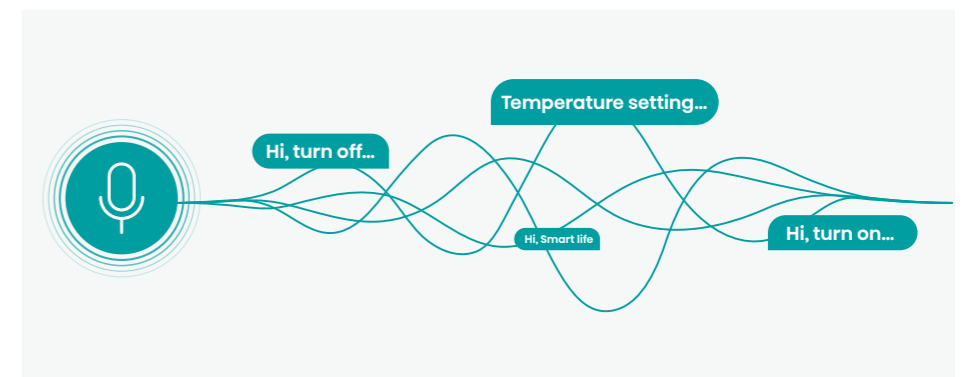

























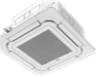
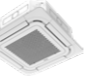

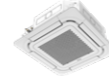
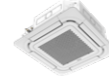
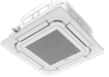
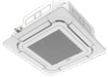









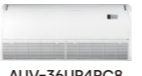
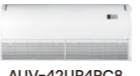















## Voice Command

When the air conditioner is connected to Wi-Fi through the Hisense module, you can control the air conditioner by voice via Amazon or Google speakers, such as turning on the AC, setting mode, and adjusting the temperature, thus freeing your hands.



# LINE UP

Indoor Units	kW	2.0kW	2.5kW	3.5kW	4.0kW	5.0kW	6.0kW	7.1kW	9.0kW	10.5kW	12.5kW	14.0kW	17.5kW	20.0kW	25.0kW	
	Btu/h	7K	9K	12K	14K	18K	21K	24K	30K	36K	42K	48K	60K	75K	85K	
Duct	Slim Duct 50Pa		 ADT-09UX4RBL8	 ADT-12UX4RBL8	 ADT-14UX4RCL8	 ADT-18UX4RCL8		 ADT-24UX4RCL8								
	MSP Duct 150Pa				 ADT-14UX4RGM8	 ADT-18UX4RGM8	 ADT-21UX4RFM8	 ADT-24UX4RFM8	 AUD-30UX4RFM8	 AUD-36UX4RQM8	 AUD-42UX4RQM8	 AUD-48UX4RQM8				
	HSP Duct ≥200Pa										 AUD-36UX4REH8	 AUD-42UX4REH8	 AUD-48UX4REH8	 AUD-60UX4REH8	 AUD-75UX4RPH8	 AUD-85UX4RPH8
Cassette	Compact Round Flow Cassette 600×600		 ACT-09UR4RCC8	 ACT-12UR4RCC8	 ACT-14UR4RCC8	 ACT-18UR4RCC8										
	Round Flow Cassette 900×900				 AUC-14UR4RJC8	 AUC-18UR4RJC8	 ACT-21UR4RJC8	 ACT-24UR4RJC8		 AUC-36UR4RKC8	 AUC-42UR4RKC8	 AUC-48UR4RKC8	 AUC-60UR4RKC8			
Console & Floor Standing	Console Standing		 AKT-09UR4RK8	 AKT-12UR4RK8	 AKT-14UR4RK8	 AKT-18UR4RK8		 AUF-24UR4RCPA8		 AUF-36UR4RMPA8		 AUF-48UR4RMPA8	 AUF-60UR4RHPA8			
Ceiling Suspended	Ceiling Suspended					 AUV-21UR4RB8	 AUV-24UR4RB8			 AUV-36UR4RC8	 AUV-42UR4RC8	 AUV-48UR4RC8	 AUV-60UR4RC8			
Outdoor Units	kW	2.0kW	2.5kW	3.5kW	4.0kW	5.0kW	6.0kW	7.1kW	9.0kW	10.5kW	12.5kW	14.0kW	17.5kW	20.0kW	25.0kW	
	Btu/h	7K	9K	12K	14K	18K	21K	24K	30K	36K	42K	48K	60K	75K	85K	
Turbo Inverter R32	1Ph		 AUW-09U4RS8	 AUW-12U4RS8	 AUW-14U4RJ8	 AUW-18U4RJ8	 AUW-21U4RK8	 AUW-24U4RK8	 AUW-30U4RK8	 AUW-36U4RW8	 AUW-42U4RW8	 AUW-48U4RW8				
	3Ph									 AUW-36U6RW8	 AUW-42U6RW8	 AUW-48U6RW8	 AUW-60U6RW8	 AUW-75U6RZ8	 AUW-85U6RZ8	
Super Inverter R32	1Ph/3Ph				 AUW-14U4RS7	 AUW-18U4RS7	 AUW-21U4RJ7	 AUW-24U4RJ7		 AUW-36U4RK7		 AUW-48U6RQ7				

# Compact Cassette

## Global LCAC Turbo Inverter R32 Inverter Expert

- WiFi Ready
- Compact Design
- Room Card Control
- Fire Leakage Control
- Individual Airflow Control
- High Ceiling
- Fresh Air Intake
- Silver Ion Filter
- Humidity Sensor



EU model(Hisense)				ACT26UR4RCC8	ACT35UR4RCC8	ACT40UR4RCC8	ACT52UR4RCC8
Indoor model				ACT-09UR4RCC8	ACT-12UR4RCC8	ACT-14UR4RCC8	ACT-18UR4RCC8
Seasonal efficiency	Cooling	Pdesignc	W	2600	3500	4100	5000
		SEER	W/W	7.20	7.00	6.70	6.70
		$\eta_{s,c}$	100%	340%	330%	316%	316%
		Energy Efficiency Class	—	A++	A++	A++	A++
	Heating (Average Season)	Pdesignh	W	3000	3000	4000	4000
		SCOP	W/W	4.60	4.60	4.40	4.40
		$\eta_{s,h}$	100%	216%	216%	207%	207%
	Heating (Warmer Season)	Pdesignh	W	3000	3000	4000	4000
		SCOP	W/W	5.35	5.35	5.35	5.35
$\eta_{s,h}$		100%	252%	252%	252%	252%	
Cooling	Capacity	Nominal	Btu/h	8871	11942	13989	17060
		Nominal	W	2600	3500	4100	5000
	Min - Max	W	1300-3600	1300-4200	1500-5000	1500-6000	
	EER	Nominal	W/W	4.19	4.00	4.00	3.67
Heating	Capacity	Nominal	Btu/h	10918	13648	15695	18766
		Nominal	W	3200	4000	4600	5500
	Min - Max	W	1300-4000	1300-5000	1500-6500	1500-7300	
	COP	Nominal	W/W	4.27	4.00	4.00	3.71
Indoor unit	Dimension	W×H×D	mm	570×215×570	570×215×570	570×215×570	570×215×570
	Weight	Net/Gross	kg	15.5/18.5	15.5/18.5	15.5/18.5	15.5/18.5
	Air Volume	Hi/Med/Lo	m³/h	600/500/400	600/500/400	700/600/510	700/600/510
	Sound Level (SPL)	Hi/Med/Lo	dB(A)	38/34/30	38/34/30	42/38/34	42/38/34
	Sound Level (PWL)	Hi	dB(A)	54	54	57	57
	Sound Level (PWL)	Level	—	B	B	C	C
Panel	Model	—	Pa	PE-QEA/LD	PE-QEA/LD	PE-QEA/LD	PE-QEA/LD
	Dimension	W×H×D	Pa	620×40×620	620×40×620	620×40×620	620×40×620
	Weight	Net/Gross	Pa	2.6/4.5	2.6/4.5	2.6/4.5	2.6/4.5

EU model(Hisense)				AUW26U4RS8	AUW35U4RS8	AUW40U4RJ8	AUW52U4RJ8
Outdoor model				AUW-09U4RS8	AUW-12U4RS8	AUW-14U4RJ8	AUW-18U4RJ8
Outdoor unit	Dimension	W×H×D	mm	810×580×280	810×580×280	860×670×310	860×670×310
	Weight	Net/Gross	kg	34/38.5	34/38.5	44/48	44/48
	Sound Level (SPL)	Hi	dB(A)	51	51	53	53
	Sound Level (PWL)	Hi	dB(A)	62	62	64	64
	Sound Level (PWL)	Level	—	C	C	C	C
	Refrigerant	Type	—	—	R32	R32	R32
Amount		kg	—	0.87	0.87	1.20	1.20
TCO2Eq		—	—	0.587	0.587	0.810	0.810
GWP		—	—	675	675	675	675
Refrigerant piping	Liquid/ Gas	mm(inch)	Φ 6.35/Φ 9.52(1/4/3/8)	Φ 6.35/Φ 9.52(1/4/3/8)	Φ 6.35/Φ 12.7(1/4/1/2)	Φ 6.35/Φ 12.7(1/4/1/2)	Φ 6.35/Φ 12.7(1/4/1/2)
	Pipe length	Max. equivalent TI Climate	m	35	35	55	55
	Pipe length	Max. equivalent Full Range	m	30	30	50	50
	Height difference	Max. (OD lower)	m	15	15	30	30
		Max. (OD higher)	m	15	15	30	30
	ADD Refrigerant AMOUNT	g/m	—	15	15	15	15
	PIPE LENGTH FOR ADDITIONAL Refrigerant	m	—	5	5	5	5
Operating Range (Outdoor)	Cooling	C	—	-15-52	-15-52	-15-52	-15-52
	Heating	C	—	-20-24	-20-24	-20-24	-20-24

# Compact Cassette

## Global LCAC Super Inverter R32 Inverter Expert

- WiFi Ready
- Compact Design
- Room Card Control
- Fire Leakage Control
- Individual Airflow Control
- High Ceiling
- Fresh Air Intake
- Silver Ion Filter
- Humidity Sensor



EU model(Hisense)				ACT40UR4RCC8	ACT52UR4RCC8
Indoor model				ACT-14UR4RCC8	ACT-18UR4RCC8
Seasonal efficiency	Cooling	Pdesignc	W	4100	5000
		SEER	W/W	6.64	6.40
		$\eta_{s,c}$	100%	313%	302%
		Energy Efficiency Class	—	A++	A++
	Heating (Average Season)	Pdesignh	W	4000	4000
		SCOP	W/W	4.10	4.10
		$\eta_{s,h}$	100%	192%	192%
	Heating (Warmer Season)	Pdesignh	W	4000	4000
		SCOP	W/W	5.40	5.40
$\eta_{s,h}$		100%	254%	254%	
Cooling	Capacity	Nominal	Btu/h	13989	17060
		Nominal	W	4100	5000
	Min - Max	W	1500-5000	1500-6000	
	EER	Nominal	W/W	3.87	3.40
Heating	Capacity	Nominal	Btu/h	15695	18766
		Nominal	W	4600	5500
	Min - Max	W	1500-5500	1500-6500	
	COP	Nominal	W/W	3.90	3.72
Indoor unit	Dimension	W×H×D	mm	570×215×570	570×215×570
	Weight	Net/Gross	kg	15.5/18.5	15.5/18.5
	Air Volume	Hi/Med/Lo	m³/h	700/600/510	700/600/510
	Sound Level (SPL)	Hi/Med/Lo	dB(A)	42/38/34	42/38/34
	Sound Level (PWL)	Hi	dB(A)	57	57
	Sound Level (PWL)	Level	—	C	C
Panel	Model	—	—	PE-QEA/LD	PE-QEA/LD
	Dimension	W×H×D	mm	620×40×620	620×40×620
	Weight	Net/Gross	kg	2.6/4.5	2.6/4.5

EU model(Hisense)				AUW40U4RS7	AUW52U4RS7
Outdoor model				AUW-14U4RS7	AUW-18U4RS7
Outdoor unit	Dimension	W×H×D	mm	810×580×280	810×580×280
	Weight	Net/Gross	kg	36/40	36/40
	Sound Level (SPL)	Hi	dB(A)	52	52
	Sound Level (PWL)	Hi	dB(A)	63	63
	Sound Level (PWL)	Level	—	C	C
	Refrigerant	Type	—	—	R32
Amount		kg	—	1.08	1.08
TCO2Eq		—	—	0.729	0.729
GWP		—	—	675	675
Refrigerant piping	Liquid/ Gas	mm(inch)	Φ 6.35/Φ 12.7(1/4/1/2)	Φ 6.35/Φ 12.7(1/4/1/2)	Φ 6.35/Φ 12.7(1/4/1/2)
	Pipe length	Max. equivalent TI Climate	m	50	50
	Pipe length	Max. equivalent Full Range	m	40	40
	Height difference	Max. (OD lower)	m	30	30
		Max. (OD higher)	m	30	30
	ADD Refrigerant AMOUNT	g/m	—	15	15
	PIPE LENGTH FOR ADDITIONAL Refrigerant	m	—	5	5
Operating Range (Outdoor)	Cooling	C	—	-15-48	-15-48
	Heating	C	—	-15-24	-15-24

# Round Flow Cassette

## Global LCAC Turbo Inverter R32 Inverter Expert

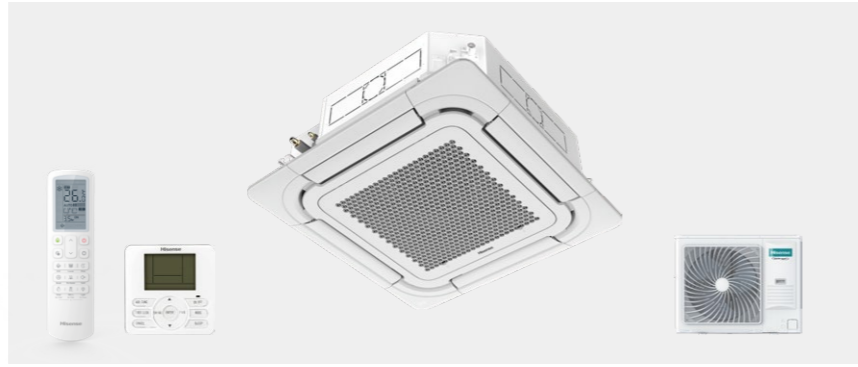

		EU model(Hisense)		ACT40UR4RJC8	ACT52UR4RJC8	ACT60UR4RJC8	ACT71UR4RJC8	AUC105UR4RKC8	AUC105UR4RKC8
		Indoor model		AUC-14UR4RJC8	AUC-18UR4RJC8	ACT-21UR4RJC8	ACT-24UR4RJC8	AUC-36UR4RKC8	AUC-36UR4RKC8
Seasonal efficiency	Cooling	Pdesignc	W	4100	5000	6200	7000	10000	10000
		SEER	W/W	7.30	7.20	7.50	7.10	7.50	7.50
		ηs,c	100%	345%	340%	354%	335%	354%	354%
		Energy Efficiency Class	—	A++	A++	A++	A++	A++	A++
	Heating (Average Season)	Pdesignh	W	4000	4000	5500	5500	8000	8000
		SCOP	W/W	4.60	4.60	4.60	4.60	4.60	4.60
		ηs,h	100%	216%	216%	216%	216%	216%	216%
		Energy Efficiency Class	—	A++	A++	A++	A++	A++	A++
	Heating (Warmer Season)	Pdesignh	W	4000	4000	5500	5500	8000	8000
		SCOP	W/W	5.35	5.35	5.35	5.35	5.40	5.40
		ηs,h	100%	252%	252%	252%	254%	254%	254%
		Energy Efficiency Class	—	A+++	A+++	A+++	A+++	A+++	A+++
Cooling	Capacity	Nominal	Btu/h	13989	17060	21154	23884	34120	34120
		Nominal	W	4100	5000	6200	7000	10000	10000
		Min - Max	W	1500-6000	1500-7000	2000-8000	2000-9000	2700-12000	2700-12000
EER	Nominal	W/W	4.40	4.00	3.90	3.70	3.85	3.85	
Heating	Capacity	Nominal	Btu/h	15695	18766	24908	27296	37532	37532
		Nominal	W	4600	5500	7300	8000	11000	11000
		Min - Max	W	1500-6500	1500-7300	2000-9000	2000-10200	2700-13000	2700-13000
		COP	Nominal	W/W	4.50	4.30	4.00	3.80	3.90
Indoor unit	Dimension	W×H×D	mm	840×236×840	840×236×840	840×236×840	840×236×840	840×236×840	840×236×840
	Weight	Net/Gross	kg	23/28	23/28	23/28	23/28	26/32	26/32
	Air Volume	Hi/Med/Lo	m³/h	1080/930/780	1080/930/780	1200/1000/840	1200/1000/840	1650/1400/1150	1650/1400/1150
	Sound Level (SPL)	Hi/Med/Lo	dB(A)	40/38/37	40/38/37	43/40/37	43/40/37	50/46/42	50/46/42
	Sound Level (PWL)	Hi	dB(A)	52	54	54	54	62	62
Panel	Sound Level (PWL)	Level	—	B	B	B	B	C	C
	Dimension	W×H×D	mm	PE-QFA/CD	PE-QFA/CD	PE-QFA/CD	PE-QFA/CD	PE-QFA/CD	PE-QFA/CD
	Packing	W×H×D	mm	950×50×950	950×50×950	950×50×950	950×50×950	950×50×950	950×50×950
	Weight	Net/Gross	kg	6.5/9	6.5/9	6.5/9	6.5/9	6.5/9.0	6.5/9.0

		EU model(Hisense)		AUW40U4RJ8	AUW52U4RJ8	AUW60U4RK8	AUW71U4RK8	AUW105U4RW8	AUW105U6RW8
		Outdoor model		AUW-14U4RJ8	AUW-18U4RJ8	AUW-21U4RK8	AUW-24U4RK8	AUW-36U4RW8	AUW-36U6RW8
Outdoor unit	Dimension	W×H×D	mm	860×670×310	860×670×310	900×750×340	900×750×340	1100×875×450	1100×875×450
	Weight	Net/Gross	kg	44/48	44/48	53/57	53/57	84/95	84/95
	Sound Level (SPL)	Hi	dB(A)	53	53	56	56	57	57
	Sound Level (PWL)	Hi	dB(A)	64	64	68	68	69	69
	Sound Level (PWL)	Level	—	C	C	D	D	D	D
Refrigerant piping	Refrigerant	Type	—	R32	R32	R32	R32	R32	R32
		Amount	kg	1.20	1.20	1.50	1.50	2.65	2.65
		TCO2Eq	—	0.810	0.810	1.013	1.013	1.789	1.789
		GWP	—	675	675	675	675	675	675
		Liquid/ Gas	mm(inch)	φ6.35/φ12.7(1/4/1/2)	φ6.35/φ12.7(1/4/1/2)	φ9.52/φ15.88(3/8/5/8)	φ9.52/φ15.88(3/8/5/8)	φ9.52/φ15.88(3/8/5/8)	φ9.52/φ15.88(3/8/5/8)
Operating Range (Outdoor)	Pipe length	Max. equivalent TI Climate	m	55	55	70	70	75	75
	Pipe length	Max. equivalent Full Range	m	50	50	50	50	50	50
	Height difference	Max. (OD lower)	m	30	30	30	30	30	30
		Max. (OD higher)	m	30	30	30	30	30	30
	ADD Refrigerant AMOUNT	g/m	15	15	35	35	35	35	
PIPE LENGTH FOR ADDITIONAL Refrigerant	m	5	5	5	5	7.5	7.5		
Operating Range (Outdoor)	Cooling	C	-15-52	-15-52	-15-52	-15-52	-15-52	-15-52	
	Heating	C	-20-24	-20-24	-20-24	-20-24	-20-24	-20-24	

		EU model(Hisense)		AUC125UR4RKC8	AUC125UR4RKC8	AUC140UR4RKC8	AUC140UR4RKC8	AUC175UR4RKC8
		Indoor model		AUC-42UR4RKC8	AUC-42UR4RKC8	AUC-48UR4RKC8	AUC-48UR4RKC8	AUC-60UR4RKC8
Seasonal efficiency	Cooling	Pdesignc	W	12100	12100	13500	13500	16000
		SEER	W/W	7.50	7.50	7.00	7.00	6.10
		ηs,c	100%	297%	297%	277%	277%	241%
		Energy Efficiency Class	—	NA	NA	NA	NA	NA
	Heating (Average Season)	Pdesignh	W	9000	9000	9000	9000	10000
		SCOP	W/W	4.50	4.50	4.50	4.50	4.00
		ηs,h	100%	177%	177%	177%	177%	157%
		Energy Efficiency Class	—	NA	NA	NA	NA	NA
	Heating (Warmer Season)	Pdesignh	W	9000	9000	9000	9000	10000
		SCOP	W/W	5.40	5.40	5.40	5.40	4.90
		ηs,h	100%	213%	213%	213%	213%	193%
		Energy Efficiency Class	—	NA	NA	NA	NA	NA
Cooling	Capacity	Nominal	Btu/h	41285	41285	46062	46062	54592
		Nominal	W	12100	12100	13500	13500	16000
		Min - Max	W	3800-13300	3800-13300	4200-15600	4200-15600	5000-18000
EER	Nominal	W/W	4.01	4.01	3.51	3.51	2.91	
Heating	Capacity	Nominal	Btu/h	46062	46062	54592	54592	59710
		Nominal	W	13500	13500	16000	16000	17500
		Min - Max	W	3300-14500	3300-14500	3600-17200	3600-17200	5000-21000
COP	Nominal	W/W	3.80	3.80	3.44	3.44	2.97	
Indoor unit	Dimension	W×H×D	mm	840×272×840	840×272×840	840×272×840	840×272×840	840×272×840
	Weight	Net/Gross	kg	26/32	26/32	26/32	26/32	26/32
	Air Volume	Hi/Med/Lo	m³/h	2000/1750/1550	2000/1750/1550	2000/1750/1550	2000/1750/1550	2100/1850/1600
	Sound Level (SPL)	Hi/Med/Lo	dB(A)	52/49/46	52/49/46	52/49/46	52/49/46	54/51/48
	Sound Level (PWL)	Hi	dB(A)	64	64	64	64	66
Panel	Sound Level (PWL)	Level	—	—	—	—	—	—
	Dimension	W×H×D	mm	PE-QFA/CD	PE-QFA/CD	PE-QFA/CD	PE-QFA/CD	PE-QFA/CD
	Packing	W×H×D	mm	950×50×950	950×50×950	950×50×950	950×50×950	950×50×950
Weight	Net/Gross	kg	6.5/9.0	6.5/9.0	6.5/9.0	6.5/9.0	6.5/9.0	

		EU model(Hisense)		AUW125U4RW8	AUW125U6RW8	AUW140U4RW8	AUW140U6RW8	AUW175U6RW8
		Outdoor model		AUW-42U4RW8	AUW-42U6RW8	AUW-48U4RW8	AUW-48U6RW8	AUW-60U6RW8
Outdoor unit	Dimension	W×H×D	mm	1100×875×450	1100×875×450	1100×875×450	1100×875×450	1100×875×450
	Weight	Net/Gross	kg	94/105	94/105	94/105	94/105	94/105
	Sound Level (SPL)	Hi	dB(A)	60	60	60	60	62
	Sound Level (PWL)	Hi	dB(A)	73	73	74	74	75
	Sound Level (PWL)	Level	—	—	—	—	—	—
	Refrigerant	Type	—	R32	R32	R32	R32	R32
		Amount	kg	3.20	3.20	3.20	3.20	3.40
		TCO2Eq	—	2.160	2.160	2.160	2.160	2.295
		GWP	—	675	675	675	675	675
	Refrigerant piping	Liquid/ Gas	mm(inch)	φ9.52/φ15.88(3/8/5/8)	φ9.52/φ15.88(3/8/5/8)	φ9.52/φ15.88(3/8/5/8)	φ9.52/φ15.88(3/8/5/8)	φ9.52/φ15.88(3/8/5/8)
Pipe length		Max. equivalent TI Climate	m	75	75	75	75	85
Pipe length		Max. equivalent Full Range	m	60	60	60	60	75
Height difference		Max. (OD lower)	m	30	30	30	30	30
		Max. (OD higher)	m	30	30	30	30	30
ADD Refrigerant AMOUNT		g/m	35	35	35	35	35	
PIPE LENGTH FOR ADDITIONAL Refrigerant	m	7.5	7.5	7.5	7.5	7.5		
Operating Range (Outdoor)	Cooling	C	-15-52	-15-52	-15-52	-15-52	-15-52	
	Heating	C	-20-24	-20-24	-20-24	-20-24	-20-24	

# Round Flow Cassette

## Global LCAC Super Inverter R32 Inverter Expert

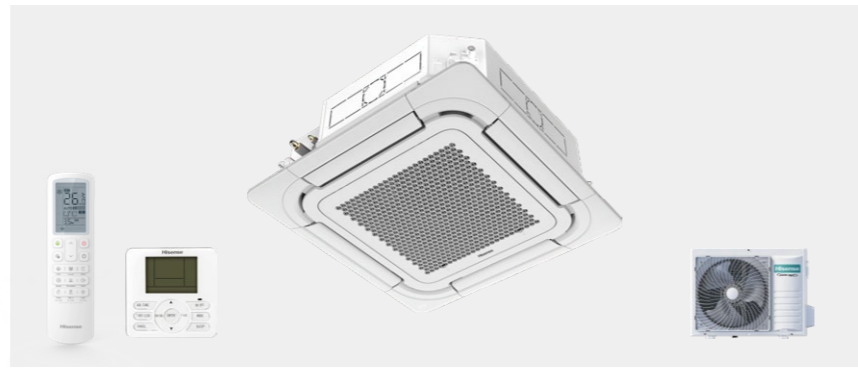

		EU model(Hisense)		ACT40UR4RJC8	ACT52UR4RJC8	ACT60UR4RJC8
		Indoor model		AUC-14UR4RJC8	AUC-18UR4RJC8	ACT-21UR4RJC8
Seasonal efficiency	Cooling	Pdesignc	W	4100	5000	6200
		SEER	W/W	7.20	7.10	7.20
		ηs,c	100%	340%	335%	340%
		Energy Efficiency Class	—	A++(New ERP B)	A+(New ERP B)	A++(New ERP B)
	Heating (Average Season)	Pdesignh	W	4000	4000	5500
		SCOP	W/W	4.40	4.40	4.10
		ηs,h	100%	207%	207%	192%
		Energy Efficiency Class	—	A+(New ERP B)	A+(New ERP B)	A+(New ERP C)
	Heating (Warmer Season)	Pdesignh	W	4000	4000	5500
		SCOP	W/W	5.35	5.35	5.35
		ηs,h	100%	252%	252%	252%
		Energy Efficiency Class	—	A+++ (New ERP A)	A+++ (New ERP A)	A+++ (New ERP A)
Cooling	Capacity	Nominal	Btu/h	13989	17060	21154
		Nominal	W	4100	5000	6200
	EER	Min - Max	W	1500-5000	1500-6000	2000-8000
		Nominal	W/W	4.10	3.70	3.71
Heating	Capacity	Nominal	Btu/h	15695	18766	24908
		Nominal	W	4600	5500	7300
		Min - Max	W	1500-5500	1500-6500	2000-9000
	COP	Nominal	W/W	4.50	4.20	3.80
Indoor unit	Dimension	W×H×D	mm	840×236×840	840×236×840	840×236×840
	Weight	Net/Gross	kg	23/28	23/28	23/28
	Air Volume	Hi/Med/Lo	m³/h	1080/930/780	1080/930/780	1200/1000/840
	Sound Level (SPL)	Hi/Med/Lo	dB(A)	40/38/37	40/38/37	43/40/37
	Sound Level (PWL)	Hi	dB(A)	52	52	54
	Sound Level (PWL)	Level	—	B	B	B
	Panel	Dimension	W×H×D	mm	PE-QFA/CD	PE-QFA/CD
Panel	Packing	W×H×D	mm	950×50×950	950×50×950	950×50×950
	Weight	Net/Gross	kg	6.5/9	6.5/9	6.5/9

		EU model(Hisense)		AUW40U4RS7	AUW52U4RS7	AUW60U4RJ7
		Outdoor model		AUW-14U4RS7	AUW-18U4RS7	AUW-21U4RJ7
Outdoor unit	Dimension	W×H×D	mm	810×580×280	810×580×280	860×670×310
	Weight	Net/Gross	kg	36/40	36/40	44.5/48.5
	Sound Level (SPL)	Hi	dB(A)	52	52	57
	Sound Level (PWL)	Hi	dB(A)	63	63	68
	Sound Level (PWL)	Level	—	C	C	D
	Refrigerant piping	Refrigerant	Type	—	R32	R32
Amount			kg	1.05	1.05	1.50
TCO2Eq			—	0.709	0.709	1.013
GWP			—	675	675	675
Liquid/ Gas			mm(inch)	φ6.35/φ12.7(1/4"1/2)	φ6.35/φ12.7(1/4"1/2)	φ9.52/φ15.88(3/8"5/8)
Operating Range (Outdoor)	Pipe length	Max. equivalent TI Climate	m	50	50	60
		Max. equivalent Full Range	m	40	40	45
		Max. (OD lower)	m	30	30	30
		Max. (OD higher)	m	30	30	30
		ADD Refrigerant AMOUNT	g/m	15	15	35
Operating Range (Outdoor)	PIPE LENGTH FOR ADDITIONAL Refrigerant		m	5	5	5
		Cooling	C	-15~48	-15~48	-15~48
Operating Range (Outdoor)	Heating		C	-15~24	-15~24	-15~24

		EU model(Hisense)		ACT71UR4RJC8	AUC105UR4RKC8
		Indoor model		ACT-24UR4RJC8	AUC-36UR4RKC8
Seasonal efficiency	Cooling	Pdesignc	W	7000	10000
		SEER	W/W	7.00	6.20
		ηs,c	100%	330%	292%
		Energy Efficiency Class	—	A++(New ERP B)	A++(New ERP C)
	Heating (Average Season)	Pdesignh	W	5500	8000
		SCOP	W/W	4.10	4.00
		ηs,h	100%	192%	187%
		Energy Efficiency Class	—	A+(New ERP C)	A+(New ERP C)
	Heating (Warmer Season)	Pdesignh	W	5500	8000
		SCOP	W/W	5.35	5.31
		ηs,h	100%	252%	250%
		Energy Efficiency Class	—	A+++ (New ERP A)	A+++ (New ERP B)
Cooling	Capacity	Nominal	Btu/h	23884	34120
		Nominal	W	7000	10000
	EER	Min - Max	W	2000-8500	2700-12000
		Nominal	W/W	3.40	3.23
Heating	Capacity	Nominal	Btu/h	27296	37532
		Nominal	W	8000	11000
		Min - Max	W	2000-9500	2700-13000
	COP	Nominal	W/W	3.72	3.72
Indoor unit	Dimension	W×H×D	mm	840×236×840	840×236×840
	Weight	Net/Gross	kg	23/28	26/32
	Air Volume	Hi/Med/Lo	m³/h	1200/1000/840	1650/1400/1150
	Sound Level (SPL)	Hi/Med/Lo	dB(A)	43/40/37	50/46/42
Panel	Sound Level (PWL)	Hi	dB(A)	54	62
	Sound Level (PWL)	Level	—	B	C
	Dimension	W×H×D	mm	PE-QFA/CD	PE-QFA/CD
	Packing	W×H×D	mm	950×50×950	950×50×950
Panel	Weight	Net/Gross	kg	6.5/9	6.5/9.0

		EU model(Hisense)		AUW71U4RJ7	AUW105U4RK7	
		Outdoor model		AUW-24U4RJ7	AUW-36U4RK7	
Outdoor unit	Dimension	W×H×D	mm	860×670×310	900×750×340	
	Weight	Net/Gross	kg	44.5/48.5	58/61	
	Sound Level (SPL)	Hi	dB(A)	57	58	
	Sound Level (PWL)	Hi	dB(A)	68	69	
	Sound Level (PWL)	Level	—	D	D	
	Refrigerant	Refrigerant	Type	—	R32	R32
			Amount	kg	1.50	1.80
			TCO2Eq	—	1.013	1.215
Refrigerant piping	GWP		—	675	675	
		Liquid/ Gas	mm(inch)	φ9.52/φ15.88(3/8"5/8)	φ9.52/φ15.88(3/8"5/8)	
		Pipe length	Max. equivalent TI Climate	m	60	65
		Pipe length	Max. equivalent Full Range	m	45	50
		Height difference	Max. (OD lower)	m	30	30
			Max. (OD higher)	m	30	30
		ADD Refrigerant AMOUNT	g/m	35	35	
		PIPE LENGTH FOR ADDITIONAL Refrigerant	m	5	5	
Operating Range (Outdoor)	Cooling	C	-15~48	-15~48		
	Heating	C	-15~24	-15~24		

# Slim Duct

## Global LCAC Turbo Inverter R32 Inverter Expert

- WIFI Ready
- ON/OFF Function
- Room Card Control
- Fire Leakage Control
- Water Level Switch
- Built-in Drain Pump
- Slim
- 1 Pa Adjust Precision
- Easy Installation



		EU model(Hisense)		ADT26UX4RBL8	ADT35UX4RBL8	ADT40UX4RCL8	ADT52UX4RCL8	
		Indoor model		ADT-09UX4RBL8	ADT-12UX4RBL8	ADT-14UX4RCL8	ADT-18UX4RCL8	
Seasonal efficiency	Cooling	Pdesignc	W	2600	3500	4100	5000	
		SEER	W/W	7.20	7.00	7.00	7.00	
		ηs,c	100%	340%	330%	330%	330%	
		Energy Efficiency Class	—	A++	A++	A++	A++	
	Heating (Average Season)	Pdesignh	W	3000	3000	4000	4000	
		SCOP	W/W	4.30	4.30	4.60	4.60	
		ηs,h	100%	202%	202%	216%	216%	
		Energy Efficiency Class	—	A+	A+	A++	A++	
	Heating (Warmer Season)	Pdesignh	W	3000	3000	4000	4000	
		SCOP	W/W	5.35	5.35	5.35	5.35	
		ηs,h	100%	252%	252%	252%	252%	
		Energy Efficiency Class	—	A+++	A+++	A+++	A+++	
Cooling	Capacity	Nominal	Btu/h	8871	11942	13989	17060	
		Nominal	W	2600	3500	4100	5000	
		Min - Max	W	1300-3600	1300-4200	1500-6000	1500-7000	
Heating	Capacity	Nominal	Btu/h	10918	13648	15695	18766	
		Nominal	W	3200	4000	4600	5500	
		Min - Max	W	1300-4000	1300-5000	1500-6500	1500-7300	
Indoor unit	COP	Nominal	W/W	4.31	4.00	4.30	4.15	
		Dimension	W×H×D	mm	910×190×447	910×190×447	1180×190×447	1180×190×447
		Weight	Net/Gross	kg	18.0/21.5	18.0/21.5	24.5/29.5	24.5/29.5
	Air Volume	Hi/Med/Lo	m³/h	600/484/400	600/484/400	900/840/780	900/840/780	
		Sound Level (SPL)	Hi/Med/Lo	dB(A)	36/33/30	36/33/30	41/37/33	41/37/33
		Sound Level (PWL)	Hi	dB(A)	53	53	57	57
	Sound Level (PWL)	Level	—	B	B	C	C	
		External Static Pressure	Rated	Pa	25+10	25+10	25+10	25+10
			Before Shipment	Pa	35	35	35	35
	Range		Pa	0-50	0-50	0-50	0-50	

		EU model(Hisense)		AUW26U4RS8	AUW35U4RS8	AUW40U4RJ8	AUW52U4RJ8
		Outdoor model		AUW-09U4RS8	AUW-12U4RS8	AUW-14U4RJ8	AUW-18U4RJ8
Outdoor unit	Dimension	W×H×D	mm	810×580×280	810×580×280	860×670×310	860×670×310
	Weight	Net/Gross	kg	34/38.5	34/38.5	44/48	44/48
	Sound Level (SPL)	Hi	dB(A)	51	51	53	53
	Sound Level (PWL)	Hi	dB(A)	62	62	64	64
	Sound Level (PWL)	Level	—	C	C	C	C
	Refrigerant	Type	—	R32	R32	R32	R32
		Amount	kg	0.87	0.87	1.20	1.20
TCO2Eq		—	0.587	0.587	0.810	0.810	
GWP		—	675	675	675	675	
Refrigerant piping	Liquid/ Gas	mm(inch)	φ6.35/φ9.52(1/4'3/8)	φ6.35/φ9.52(1/4'3/8)	φ6.35/φ12.7(1/4'1/2)	φ6.35/φ12.7(1/4'1/2)	
	Pipe length	Max. equivalent TI Climate	m	35	35	55	55
	Pipe length	Max. equivalent Full Range	m	30	30	50	50
	Height difference	Max. (OD lower)	m	15	15	30	30
		Max. (OD higher)	m	15	15	30	30
	ADD Refrigerant AMOUNT	g/m	15	15	15	15	
	PIPE LENGTH FOR ADDITIONAL Refrigerant	m	5	5	5	5	
Operating Range (Outdoor)	Cooling	C	-15-52	-15-52	-15-52	-15-52	
	Heating	C	-20-24	-20-24	-20-24	-20-24	

# Slim Duct

## Global LCAC Super Inverter R32 Inverter Expert

- WIFI Ready
- ON/OFF Function
- Room Card Control
- Fire Leakage Control
- Water Level Switch
- Built-in Drain Pump
- Slim
- 1 Pa Adjust Precision
- Easy Installation



		EU model(Hisense)		ADT40UX4RCL8	ADT52UX4RCL8	ADT71UX4RCL8	
		Indoor model		ADT-14UX4RCL8	ADT-18UX4RCL8	ADT-24UX4RCL8	
Seasonal efficiency	Cooling	Pdesignc	W	4100	5000	7000	
		SEER	W/W	6.64	7.00	6.30	
		ηs,c	100%	313%	330%	297%	
		Energy Efficiency Class	—	A++	A++	A++	
	Heating (Average Season)	Pdesignh	W	4000	4000	5500	
		SCOP	W/W	4.30	4.30	4.10	
		ηs,h	100%	202%	202%	192%	
		Energy Efficiency Class	—	A+	A+	A+	
	Heating (Warmer Season)	Pdesignh	W	4000	4000	5500	
		SCOP	W/W	5.40	5.40	5.40	
		ηs,h	100%	254%	254%	254%	
		Energy Efficiency Class	—	A+++	A+++	A+++	
Cooling	Capacity	Nominal	Btu/h	13989	17060	23884	
		Nominal	W	4100	5000	7000	
		Min - Max	W	1500-5000	1500-6000	2000-8500	
Heating	Capacity	Nominal	Btu/h	15695	18766	27296	
		Nominal	W	4600	5500	8000	
		Min - Max	W	1500-5500	1500-6500	2000-9500	
Indoor unit	COP	Nominal	W/W	4.10	3.79	3.33	
		Dimension	W×H×D	mm	1180×190×447	1180×190×447	1180×190×447
		Weight	Net/Gross	kg	24.5/29.5	24.5/29.5	24.5/29.5
	Air Volume	Hi/Med/Lo	m³/h	900/840/780	900/840/780	1000/900/800	
		Sound Level (SPL)	Hi/Med/Lo	dB(A)	41/37/33	41/37/33	42/38/34
		Sound Level (PWL)	Hi	dB(A)	57	57	58
	Sound Level (PWL)	Level	—	C	C	C	
		External Static Pressure	Rated	Pa	25+10	25+10	25+10
			Before Shipment	Pa	35	35	35
	Range		Pa	0-50	0-50	0-50	

		EU model(Hisense)		AUW40U4RS7	AUW52U4RS7	AUW71U4RJ7
		Outdoor model		AUW-14U4RS7	AUW-18U4RS7	AUW-24U4RJ7
Outdoor unit	Dimension	W×H×D	mm	810×580×280	810×580×280	860×670×310
	Weight	Net/Gross	kg	36/40	36/40	44.5/48.5
	Sound Level (SPL)	Hi	dB(A)	52	52	57
	Sound Level (PWL)	Hi	dB(A)	63	63	68
	Sound Level (PWL)	Level	—	C	C	D
	Refrigerant	Type	—	R32	R32	R32
		Amount	kg	1.08	1.08	1.50
TCO2Eq		—	0.729	0.729	1.013	
GWP		—	675	675	675	
Refrigerant piping	Liquid/ Gas	mm(inch)	φ6.35/φ12.7(1/4'1/2)	φ6.35/φ12.7(1/4'1/2)	φ6.35/φ15.88(3/8'5/8)	
	Pipe length	Max. equivalent TI Climate	m	50	50	60
	Pipe length	Max. equivalent Full Range	m	40	40	45
	Height difference	Max. (OD lower)	m	30	30	30
		Max. (OD higher)	m	30	30	30
	ADD Refrigerant AMOUNT	g/m	15	15	35	
	PIPE LENGTH FOR ADDITIONAL Refrigerant	m	5	5	5	
Operating Range (Outdoor)	Cooling	C	-15-48	-15-48	-15-48	
	Heating	C	-15-24	-15-24	-15-24	

# MSP Duct

## Global LCAC Turbo Inverter R32 Inverter Expert

- WIFI Ready
- ON/OFF Function
- Room Card Control
- Fire Leakage Control
- Water Level Switch
- Built-in Drain Pump
- Slim
- 1 Pa Adjust Precision
- Easy Installation



		EU model(Hisense)		ADT40UX4RGM8	ADT52UX4RGM8	ADT60UX4RFM8	ADT71UX4RFM8	AUD90UX4RFM8
		Indoor model		ADT-14UX4RGM8	ADT-18UX4RGM8	ADT-21UX4RFM8	ADT-24UX4RFM8	AUD-30UX4RFM8
Seasonal efficiency	Cooling	Pdesignc	W	4100	5000	6200	7000	8800
		SEER	W/W	7.20	7.10	7.50	7.30	6.80
		ηs,c	100%	340%	335%	354%	345%	321%
		Energy Efficiency Class	—	A++	A++	A++	A++	A++
	Heating (Average Season)	Pdesignh	W	4000	4000	5500	5500	5500
		SCOP	W/W	4.60	4.60	4.60	4.60	4.40
		ηs,h	100%	216%	216%	216%	216%	207%
		Energy Efficiency Class	—	A++	A++	A++	A++	A+
	Heating (Warmer Season)	Pdesignh	W	4000	4000	5500	5500	5500
		SCOP	W/W	5.50	5.50	5.40	5.40	5.40
		ηs,h	100%	259%	259%	254%	254%	254%
		Energy Efficiency Class	—	A+++	A+++	A++	A++	A++
Cooling	Capacity	Nominal	Btu/h	13989	17060	21154	23884	30026
		Nominal	W	4100	5000	6200	7000	8800
		Min - Max	W	1500-6000	1500-7000	2000-8000	2000-9000	2000-10000
EER	Nominal	W/W	4.10	4.00	4.13	4.00	3.31	
Heating	Capacity	Nominal	Btu/h	15695	18766	24908	27296	32414
		Nominal	W	4600	5500	7300	8000	9500
		Min - Max	W	1500-6500	1500-7300	2000-9000	2000-10200	2000-10500
		Nominal	W/W	4.18	4.10	4.17	4.06	3.73
Indoor unit	Dimension	W×H×D	mm	800×245×700	800×245×700	1100×245×700	1100×245×700	1100×245×700
	Weight	Net/Gross	kg	26.5/31	26.5/31	33.5/38.5	33.5/38.5	33.5/38.5
	Air Volume	Hi/Med/Lo	m³/h	900/800/700	900/800/700	1250/1120/1000	1250/1120/1000	1250/1120/1000
	Sound Level (SPL)	Hi/Med/Lo	dB(A)	37/34/32	37/34/32	35/33/31	35/33/31	37/35/33
	Sound Level (PWL)	Hi	dB(A)	54	54	54	54	56
	Sound Level (PWL)	Level	—	B	B	B	B	C
	External Static Pressure	Rated	Pa	25+10	25+10	25+10	25+10	37+10
		Before Shipment	Pa	100	100	100	100	100
		Range	Pa	0-150	0-150	0-150	0-150	0-150

		EU model(Hisense)		AUW40U4RJ8	AUW52U4RJ8	AUW60U4RK8	AUW71U4RK8	AUW90U4RK8	
		Outdoor model		AUW-14U4RJ8	AUW-18U4RJ8	AUW-21U4RK8	AUW-24U4RK8	AUW-30U4RK8	
Outdoor unit	Dimension	W×H×D	mm	860×670×310	860×670×310	900×750×340	900×750×340	900×750×340	
	Weight	Net/Gross	kg	44/48	44/48	53/57	53/57	53/57	
	Sound Level (SPL)	Hi	dB(A)	53	53	56	56	56	
	Sound Level (PWL)	Hi	dB(A)	64	64	68	68	68	
	Sound Level (PWL)	Level	—	C	C	D	D	D	
	Refrigerant	Type	—	R32	R32	R32	R32	R32	R32
		Amount	kg	1.20	1.20	1.5	1.5	1.5	
		TCO2Eq	—	0.810	0.810	1.013	1.013	1.013	
GWP		—	675	675	675	675	675		
Refrigerant piping	Liquid/ Gas	mm(inch)	Φ6.35/Φ12.7(1/4"/1/2")	Φ6.35/Φ12.7(1/4"/1/2")	Φ9.52/Φ15.88(3/8"/5/8")	Φ9.52/Φ15.88(3/8"/5/8")	Φ9.52/Φ15.88(3/8"/5/8")		
	Pipe length	Max. equivalent TI Climate	m	55	55	70	70	70	
	Pipe length	Max. equivalent Full Range	m	50	50	50	50	50	
	Height difference	Max. (OD lower)	m	30	30	30	30	30	
		Max. (OD higher)	m	30	30	30	30	30	
	ADD Refrigerant AMOUNT	g/m	15	15	35	35	35		
	PIPE LENGTH FOR ADDITIONAL Refrigerant	m	5	5	5	5	5		
Operating Range (Outdoor)	Cooling	C	-15-52	-15-52	-15-52	-15-52	-15-52		
	Heating	C	-20-24	-20-24	-15-24	-15-24	-15-24		

# MSP Duct

## Global LCAC Turbo Inverter R32 Inverter Expert

- WIFI Ready
- ON/OFF Function
- Room Card Control
- Fire Leakage Control
- Water Level Switch
- Built-in Drain Pump
- Slim
- 1 Pa Adjust Precision
- Easy Installation



		EU model(Hisense)		AUD105UX4RQM8	AUD105UX4RQM8	AUD125UX4RQM8	AUD125UX4RQM8	AUD140UX4RQM8	AUD140UX4RQM8
		Indoor model		AUD-36UX4RQM8	AUD-36UX4RQM8	AUD-42UX4RQM8	AUD-42UX4RQM8	AUD-48UX4RQM8	AUD-48UX4RQM8
Seasonal efficiency	Cooling	Pdesignc	W	10000	10000	12100	12100	13500	13500
		SEER	W/W	7.10	7.10	7.10	7.10	6.85	6.85
		ηs,c	100%	281%	281%	281%	281%	271%	271%
		Energy Efficiency Class	—	A++	A++	NA	NA	NA	NA
	Heating (Average Season)	Pdesignh	W	8000	8000	9000	9000	9000	9000
		SCOP	W/W	4.40	4.40	4.50	4.50	4.50	4.50
		ηs,h	100%	173%	173%	177%	177%	177%	177%
		Energy Efficiency Class	—	A+	A+	NA	NA	NA	NA
	Heating (Warmer Season)	Pdesignh	W	8000	8000	9000	9000	9000	9000
		SCOP	W/W	5.40	5.40	5.40	5.40	5.40	5.40
		ηs,h	100%	254%	254%	254%	254%	254%	254%
		Energy Efficiency Class	—	A+++	A+++	A+++	A+++	A+++	A+++
Cooling	Capacity	Nominal	Btu/h	34120	34120	41285	41285	46062	46062
		Nominal	W	10000	10000	12100	12100	13500	13500
		Min - Max	W	2000-12000	2000-12000	5000-18000	5000-18000	5000-18000	5000-18000
EER	Nominal	W/W	3.80	3.80	3.81	3.81	3.51	3.51	
Heating	Capacity	Nominal	Btu/h	37532	37532	46062	46062	54592	54592
		Nominal	W	11000	11000	13500	13500	16000	16000
		Min - Max	W	2700-13000	2700-13000	5000-21000	5000-21000	5000-21000	5000-21000
		Nominal	W/W	4.10	4.10	4.01	4.01	3.72	3.72
Indoor unit	Dimension	W×H×D	mm	1400×245×700	1400×245×700	1400×245×700	1400×245×700	1400×245×700	1400×245×700
	Weight	Net/Gross	kg	43.0/49.0	43.0/49.0	43.0/49.0	43.0/49.0	43.0/49.0	43.0/49.0
	Air Volume	Hi/Med/Lo	m³/h	1800/1600/1350	1800/1600/1350	2300/2000/1750	2300/2000/1750	2300/2000/1750	2300/2000/1750
	Sound Level (SPL)	Hi/Med/Lo	dB(A)	42/39/36	42/39/36	46/43/40	46/43/40	46/43/40	46/43/40
	Sound Level (PWL)	Hi	dB(A)	60	60	64	64	64	64
	Sound Level (PWL)	Level	—	C	C	—	—	—	—
	External Static Pressure	Rated	Pa	37+10	37+10	50+10	50+10	50+10	50+10
		Before Shipment	Pa	100	100	100	100	100	100
		Range	Pa	0-150	0-150	0-150	0-150	0-150	0-150

		EU model(Hisense)		AUW105U4RW8	AUW105U6RW8	AUW125U4RW8	AUW125U6RW8	AUW140U4RW8	AUW140U6RW8	
		Outdoor model		AUW-36U4RW8	AUW-36U6RW8	AUW-42U4RW8	AUW-42U6RW8	AUW-48U4RW8	AUW-48U6RW8	
Outdoor unit	Dimension	W×H×D	mm	1100×875×450	900×1170×320	1100×875×450	1100×875×450	1100×875×450	1100×875×450	
	Weight	Net/Gross	kg	84/95	81/90	94/105	94/105	94/105	94/105	
	Sound Level (SPL)	Hi	dB(A)	57	57	60	60	60	60	
	Sound Level (PWL)	Hi	dB(A)	69	68	73	73	74	74	
	Sound Level (PWL)	Level	—	D	D	—	—	—	—	
	Refrigerant	Type	—	R32	R32	R32	R32	R32	R32	R32
		Amount	kg	2.65	2.65	3.20	3.20	3.20	3.20	
		TCO2Eq	—	1.789	1.789	2.160	2.160	2.160	2.160	
GWP		—	675	675	675	675	675	675		
Refrigerant piping	Liquid/ Gas	mm(inch)	Φ9.52/Φ15.88(3/8"/5/8")	Φ9.52/Φ15.88(3/8"/5/8")	Φ9.52/Φ15.88(3/8"/5/8")	Φ9.52/Φ15.88(3/8"/5/8")	Φ9.52/Φ15.88(3/8"/5/8")			
	Pipe length	Max. equivalent TI Climate	m	75	75	75	75	75		
	Pipe length	Max. equivalent Full Range	m	50	50	60	60	60		
	Height difference	Max. (OD lower)	m	30	30	30	30	30		
		Max. (OD higher)	m	30	30	30	30	30		
	ADD Refrigerant AMOUNT	g/m	35	35	35	35	35			
	PIPE LENGTH FOR ADDITIONAL Refrigerant	m	7.5	7.5	7.5	7.5	7.5			
Operating Range (Outdoor)	Cooling	C	-15-52	-15-52	-15-52	-15-52	-15-52			
	Heating	C	-20-24	-20-24	-20-24	-20-24	-20-24			

# MSP Duct

## Global LCAC Super Inverter R32 Inverter Expert

- WIFI Ready
- ON/OFF Function
- Room Card Control
- Fire Leakage Control
- Water Level Switch
- Built-in Drain Pump
- Slim
- 1 Pa Adjust Precision
- Easy Installation



EU model(Hisense)				ADT52UX4RGM8	AUD105UX4RQM8
Indoor model				ADT-18UX4RGM8	AUD-36UX4RQM8
Seasonal efficiency	Cooling	Pdesignc	W	5000	10000
		SEER	W/W	6.10	6.40
		ηs,c	100%	287%	253%
		Energy Efficiency Class	—	A++	A++
	Heating (Average Season)	Pdesignh	W	4000	7400
		SCOP	W/W	4.10	4.00
		ηs,h	100%	192%	157%
		Energy Efficiency Class	—	A+	A+
	Heating (Warmer Season)	Pdesignh	W	4000	7400
		SCOP	W/W	5.40	5.40
		ηs,h	100%	254%	254%
		Energy Efficiency Class	—	A+++	A+++
Cooling	Capacity	Nominal	Btu/h	17060	34120
		Nominal	W	5000	10000
		Min - Max	W	1500-7000	2000-12000
EER	Nominal	W/W	3.23	3.30	
Heating	Capacity	Nominal	Btu/h	18766	37532
		Nominal	W	5500	11000
		Min - Max	W	1500-7300	2700-13000
		COP	Nominal	W/W	3.71
Indoor unit	Dimension	W×H×D	mm	800×245×700	1400×245×700
	Weight	Net/Gross	kg	26.5/31	43.0/49.0
	Air Volume	Hi/Med/Lo	m³/h	900/800/700	1800/1600/1350
	Sound Level (SPL)	Hi/Med/Lo	dB(A)	37/34/32	42/39/36
	Sound Level (PWL)	Hi	dB(A)	54	59
	Sound Level (PWL)	Level	—	B	C
	External Static Pressure	Rated	Pa	25+10	37+10
		Before Shipment	Pa	100	100
Range		Pa	0-150	0-160	

EU model(Hisense)				AUW52U4RS7	AUW105U4RK7
Outdoor model				AUW-18U4RS7	AUW-36U4RK7
Outdoor unit	Dimension	W×H×D	mm	810×580×280	1100×875×450
	Weight	Net/Gross	kg	36/40	84.0/95.0
	Sound Level (SPL)	Hi	dB(A)	52	—
	Sound Level (PWL)	Hi	dB(A)	63	69
	Sound Level (PWL)	Level	—	C	D
	Refrigerant	Type	—	R32	R32
Amount		kg	1.05	2.65	
TCO2Eq		—	0.709	1.789	
GWP		—	675	675	
Refrigerant piping	Liquid/ Gas	mm(inch)	φ6.35/φ12.7(1/4"/1/2")	φ9.52/φ15.88(3/8"/5/8")	
	Pipe length	Max. equivalent TI Climate	m	50	65
		Max. equivalent Full Range	m	40	50
	Height difference	Max. (OD lower)	m	30	30
		Max. (OD higher)	m	30	30
	ADD Refrigerant AMOUNT	g/m	15	35	
	PIPE LENGTH FOR ADDITIONAL Refrigerant	m	5	7.5	
Operating Range (Outdoor)	Cooling	C	-15-48	-15-48	
	Heating	C	-15-24	-15-24	

# HSP Duct

## Global LCAC Turbo Inverter R32 Inverter Expert

- WIFI Ready
- ON/OFF Function
- Room Card Control
- Fire Leakage Control
- Water Level Switch
- Built-in Drain Pump
- Slim
- 1 Pa Adjust Precision
- Easy Installation

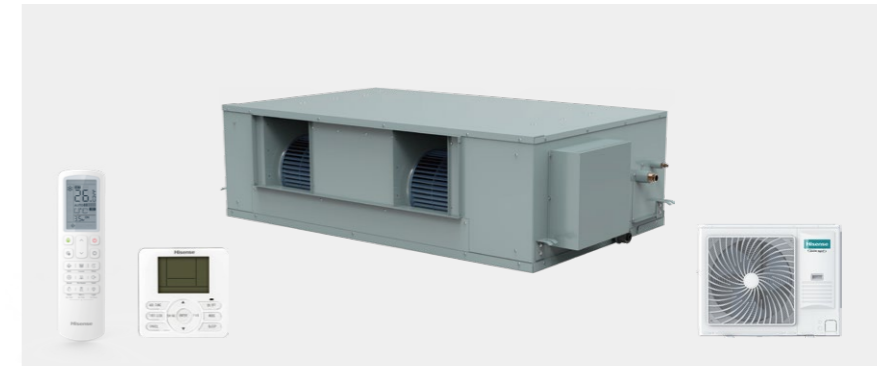

EU model(Hisense)				AUD105UX4REH8	AUD105UX4REH8	AUD125UX4REH8	AUD125UX4REH8
Indoor model				AUD-36UX4REH8	AUD-36UX4REH8	AUD-42UX4REH8	AUD-42UX4REH8
Seasonal efficiency	Cooling	Pdesignc	W	10000	10000	12100	12100
		SEER	W/W	7.10	7.10	7.50	7.50
		ηs,c	100%	335%	335%	297%	297%
		Energy Efficiency Class	—	A++	A++	NA	NA
	Heating (Average Season)	Pdesignh	W	8000	8000	9000	9000
		SCOP	W/W	4.40	4.40	4.50	4.50
		ηs,h	100%	207%	207%	177%	177%
		Energy Efficiency Class	—	A+	A+	NA	NA
	Heating (Warmer Season)	Pdesignh	W	8000	8000	9000	9000
		SCOP	W/W	5.40	5.40	5.40	5.40
		ηs,h	100%	254%	254%	213%	213%
		Energy Efficiency Class	—	A+++	A+++	NA	NA
Cooling	Capacity	Nominal	Btu/h	34120	34120	41285	41285
		Nominal	W	10000	10000	12100	12100
		Min - Max	W	2700-12000	2700-12000	3900-13200	3900-13200
EER	Nominal	W/W	3.70	3.80	3.90	3.90	
Heating	Capacity	Nominal	Btu/h	37532	37532	46062	46062
		Nominal	W	11000	11000	13500	13500
		Min - Max	W	2700-13000	2700-13000	3400-14400	3400-14400
		COP	Nominal	W/W	4.00	4.00	4.01
Indoor unit	Dimension	W×H×D	mm	1400×300×800	1400×300×800	1400×300×800	1400×300×800
	Weight	Net/Gross	kg	51/57	51/57	51/57	51/57
	Air Volume	Hi/Med/Lo	m³/h	2000/1800/1600	2000/1800/1600	2400/2200/1900	2400/2200/1900
	Sound Level (SPL)	Hi/Med/Lo	dB(A)	42/39/36	42/39/36	43/40/37	43/40/37
	Sound Level (PWL)	Hi	dB(A)	59	59	63	63
	Sound Level (PWL)	Level	—	C	C	—	—
	External Static Pressure	Rated	Pa	37+10	37+10	50+10	50+10
		Before Shipment	Pa	100	100	100	100
Range		Pa	0-200	0-200	0-200	0-200	

EU model(Hisense)				AUW105U4RW8	AUW105U6RW8	AUW125U4RW8	AUW125U6RW8
Outdoor model				AUW-36U4RW8	AUW-36U6RW8	AUW-42U4RW8	AUW-42U6RW8
Outdoor unit	Dimension	W×H×D	mm	1100×875×450	1100×875×450	1100×875×450	1100×875×450
	Weight	Net/Gross	kg	84/95	81/90	94/105	94/105
	Sound Level (SPL)	Hi	dB(A)	57	57	60	60
	Sound Level (PWL)	Hi	dB(A)	69	68	73	73
	Sound Level (PWL)	Level	—	D	D	—	—
	Refrigerant	Type	—	R32	R32	R32	R32
Amount		kg	2.65	2.65	3.20	3.20	
TCO2Eq		—	1.789	1.789	2.160	2.160	
GWP		—	675	675	675	675	
Refrigerant piping	Liquid/ Gas	mm(inch)	φ9.52/φ15.88(3/8"/5/8")	φ9.52/φ15.88(3/8"/5/8")	φ9.52/φ15.88(3/8"/5/8")	φ9.52/φ15.88(3/8"/5/8")	
	Pipe length	Max. equivalent TI Climate	m	75	75	75	75
		Max. equivalent Full Range	m	50	50	60	60
	Height difference	Max. (OD lower)	m	30	30	30	30
		Max. (OD higher)	m	30	30	30	30
	ADD Refrigerant AMOUNT	g/m	35	35	35	35	
	PIPE LENGTH FOR ADDITIONAL Refrigerant	m	7.5	7.5	7.5	7.5	
Operating Range (Outdoor)	Cooling	C	-15-52	-15-52	-15-52	-15-52	
	Heating	C	-20-24	-20-24	-20-24	-20-24	

		EU model(Hisense)		AUD140UX4REH8	AUD140UX4REH8	AUD175UX4REH8	AUD200UX4RPH8	AUD250UX4RPH8
		Indoor model		AUD-48UX4REH8	AUD-48UX4REH8	AUD-60UX4REH8	AUD-75UX4RPH8	AUD-85UX4RPH8
Seasonal efficiency	Cooling	Pdesignc	W	13500	13500	16000	19000	23000
		SEER	W/W	7.00	7.00	6.10	6.00	5.82
		ηs,c	100%	277%	277%	241%	237%	230%
		Energy Efficiency Class	—	NA	NA	NA	NA	NA
	Heating (Average Season)	Pdesignh	W	9000	9000	10000	17000	17000
		SCOP	W/W	4.50	4.50	4.00	3.90	3.90
		ηs,h	100%	177%	177%	157%	153%	153%
		Energy Efficiency Class	—	NA	NA	NA	NA	NA
	Heating (Warmer Season)	Pdesignh	W	9000	9000	10000	17000	17000
SCOP		W/W	5.40	5.40	5.20	4.90	4.90	
ηs,h		100%	213%	213%	205%	193%	193%	
	Energy Efficiency Class	—	NA	NA	NA	NA	NA	
Cooling	Capacity	Nominal	Btu/h	46062	46062	54592	64828	78476
		Nominal	W	13500	13500	16000	19000	23000
		Min - Max	W	4300-15500	4300-15500	5000-18000	7000-23500	7500-24500
EER	Nominal	W/W	3.51	3.51	3.00	3.00	2.35	
Heating	Capacity	Nominal	Btu/h	54592	54592	58004	75064	85300
		Nominal	W	16000	16000	17000	22000	25000
		Min - Max	W	3700-17100	3700-17100	5000-21000	6000-25000	6500-27500
COP	Nominal	W/W	3.72	3.72	3.71	3.75	3.45	
Indoor unit	Dimension	W×H×D	mm	1400×300×800	1400×300×800	1400×300×800	1400×420×858	1400×420×858
	Weight	Net/Gross	kg	51/57	51/57	51/57	84/93.5	84/93.5
	Air Volume	Hi/Med/Lo	m³/h	2400/2200/1900	2400/2200/1900	2500/2250/1900	4400/3900/3400	4400/3900/3400
	Sound Level (SPL)	Hi/Med/Lo	dB(A)	43/40/37	43/40/37	46/41/37	58/55/52	58/55/52
	Sound Level (PWL)	Hi	dB(A)	64	64	65	81	81
	Sound Level (PWL)	Level	—	—	—	—	—	—
	External Static Pressure	Rated	Pa	50+10	50+10	50+10	50+10	62+10
		Before Shipment	Pa	100	100	100	150	150
		Range	Pa	0-200	0-200	0-200	0-250	0-250

		EU model(Hisense)		AUW140U4RW8	AUW140U6RW8	AUW175U6RW8	AUW200U6RZ8	AUW250U6RZ8
		Outdoor model		AUW-48U4RW8	AUW-48U6RW8	AUW-60U6RW8	AUW-75U6RZ8	AUW-85U6RZ8
Outdoor unit	Dimension	W×H×D	mm	1100×875×450	1100×875×450	1100×875×450	1100×1650×390	1100×1650×390
	Weight	Net/Gross	kg	94/105	94/105	94/105	140/157	140/157
	Sound Level (SPL)	Hi	dB(A)	60	60	62	61	61
	Sound Level (PWL)	Hi	dB(A)	74	74	75	76	76
	Sound Level (PWL)	Level	—	—	—	—	—	—
	Refrigerant	Type	—	R32	R32	R32	R32	R32
Amount		kg	3.20	3.20	3.40	4.60	4.60	
TCO2Eq		—	2.160	2.160	2.295	3.105	3.105	
GWP		—	675	675	675	675	675	
Refrigerant piping	Liquid/ Gas	mm(inch)	φ9.52/φ15.88(3/8/5/8)	φ9.52/φ15.88(3/8/5/8)	φ9.52/φ15.88(3/8/5/8)	φ9.52/φ22.22(3/8/7/8)	φ9.52/φ22.22(3/8/7/8)	
	Pipe length	Max. equivalent TI Climate	m	75	75	85	100	
	Pipe length	Max. equivalent Full Range	m	60	60	75	75	
	Height difference	Max. (OD lower)	m	30	30	30	30	
		Max. (OD higher)	m	30	30	30	30	
	ADD Refrigerant AMOUNT	g/m	35	35	35	35		
PIPE LENGTH FOR ADDITIONAL Refrigerant	m	7.5	7.5	7.5	7.5			
Operating Range (Outdoor)	Cooling	°C	-15-52	-15-52	-15-52	-15-50	-15-50	
	Heating	°C	-20-24	-20-24	-20-24	-20-24	-20-24	

## HSP Duct

## Global LCAC Super Inverter R32 Inverter Expert

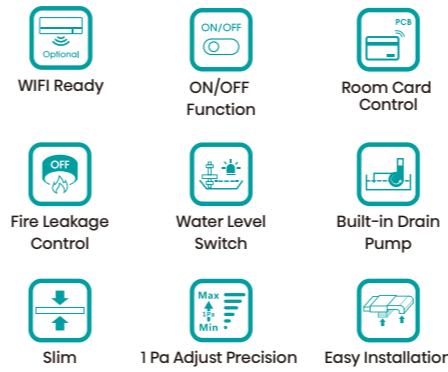

		EU model(Hisense)		AUD105UX4REH8
		Indoor model		AUD-36UX4REH8
Seasonal efficiency	Cooling	Pdesignc	W	10000
		SEER	W/W	6.10
		ηs,c	100%	287%
		Energy Efficiency Class	—	A++
	Heating (Average Season)	Pdesignh	W	8000
		SCOP	W/W	4.00
		ηs,h	100%	187%
		Energy Efficiency Class	—	A+
	Heating (Warmer Season)	Pdesignh	W	8000
SCOP		W/W	5.35	
ηs,h		100%	252%	
	Energy Efficiency Class	—	A+++	
Cooling	Capacity	Nominal	Btu/h	34120
		Nominal	W	10000
		Min - Max	W	2700-12000
EER	Nominal	W/W	3.30	
Heating	Capacity	Nominal	Btu/h	37532
		Nominal	W	11000
		Min - Max	W	2700-13000
COP	Nominal	W/W	3.75	
Indoor unit	Dimension	W×H×D	mm	1400×300×800
	Weight	Net/Gross	kg	53/59
	Air Volume	Hi/Med/Lo	m³/h	2000/1800/1600
	Sound Level (SPL)	Hi/Med/Lo	dB(A)	42/39/36
	Sound Level (PWL)	Hi	dB(A)	59
	Sound Level (PWL)	Level	—	C
	External Static Pressure	Rated	Pa	50+10
		Before Shipment	Pa	100
		Range	Pa	0-200

		EU model(Hisense)		AUW105U4RK7
		Outdoor model		AUW-36U4RK7
Outdoor unit	Dimension	W×H×D	mm	900×750×340
	Weight	Net/Gross	kg	55/59
	Sound Level (SPL)	Hi	dB(A)	58
	Sound Level (PWL)	Hi	dB(A)	69
	Sound Level (PWL)	Level	—	D
	Refrigerant	Type	—	R32
Amount		kg	1.80	
TCO2Eq		—	1.215	
GWP		—	675	
Refrigerant piping	Liquid/ Gas	mm(inch)	φ9.52/φ15.88(3/8/5/8)	
	Pipe length	Max. equivalent TI Climate	m	65
	Pipe length	Max. equivalent Full Range	m	50
	Height difference	Max. (OD lower)	m	30
		Max. (OD higher)	m	30
	ADD Refrigerant AMOUNT	g/m	35	
PIPE LENGTH FOR ADDITIONAL Refrigerant	m	5		
Operating Range (Outdoor)	Cooling	°C	-15-48	
	Heating	°C	-15-24	

# Ceiling Suspended

## Global LCAC Turbo Inverter R32 Inverter Expert

- WIFI Ready
- ON/OFF Function
- Emergency Use
- Anti-bacteria Fin
- Multiple Installation Types
- High Ceiling
- Easy Cleaning Filter
- Silver Ion Filter
- I Feel



EU model(Hisense)				AUV105UR4RC8	AUV105UR4RC8	AUV125UR4RC8	AUV125UR4RC8
Indoor model				AUV-36UR4RC8	AUV-36UR4RC8	AUV-42UR4RC8	AUV-42UR4RC8
Seasonal efficiency	Cooling	Pdesignc	W	9500	9500	12100	12100
		SEER	W/W	6.80	6.80	6.50	6.50
		ηs,c	100%	321%	321%	257%	257%
		Energy Efficiency Class	—	A++	A++	NA	NA
	Heating (Average Season)	Pdesignh	W	8000	8000	9000	9000
		SCOP	W/W	4.30	4.30	4.40	4.40
		ηs,h	100%	202%	202%	173%	173%
		Energy Efficiency Class	—	A+	A+	NA	NA
	Heating (Warmer Season)	Pdesignh	W	8000	8000	9000	9000
		SCOP	W/W	5.40	5.40	5.40	5.40
		ηs,h	100%	254%	254%	213%	213%
		Energy Efficiency Class	—	A+++	A+++	NA	NA
Cooling	Capacity	Nominal	Btu/h	32414	32414	41285	41285
		Nominal	W	9500	9500	12100	12100
	EER	Min - Max	W	2700-12000	2700-12000	3800-13300	3800-13300
		Nominal	W/W	3.65	3.61	3.61	3.61
Heating	Capacity	Nominal	Btu/h	37532	37532	46062	46062
		Nominal	W	11000	11000	13500	13500
		Min - Max	W	2700-13000	2700-13000	3300-14500	3300-14500
	COP	Nominal	W/W	3.73	3.73	3.71	3.71
Indoor unit	Dimension	W×H×D	mm	1580×680×230	1580×680×230	1580×680×230	1580×680×230
	Weight	Net/Gross	kg	46/54	46/54	46/54	46/54
	Air Volume	Hi/Med/Lo	m³/h	1700/1500/1300	1700/1500/1300	2200/1900/1600	2200/1900/1600
	Sound Level (SPL)	Hi/Med/Lo	dB(A)	56/51/48	56/51/48	56/51/48	56/51/48
	Sound Level (PWL)	Hi	dB(A)	65	65	71	71
	Sound Level (PWL)	Level	—	D	D	—	—

EU model(Hisense)				AUW105U4RW8	AUW105U6RW8	AUW125U4RW8	AUW125U6RW8
Outdoor model				AUW-36U4RW8	AUW-36U6RW8	AUW-42U4RW8	AUW-42U6RW8
Outdoor unit	Dimension	W×H×D	mm	1100×875×450	900×1170×320	1100×875×450	1100×875×450
	Weight	Net/Gross	kg	84/95	81/90	94/105	94/105
	Sound Level (SPL)	Hi	dB(A)	57	57	60	60
	Sound Level (PWL)	Hi	dB(A)	69	68	73	73
	Sound Level (PWL)	Level	—	D	D	—	—
	Refrigerant	Refrigerant	Type	—	R32	R32	R32
Amount			kg	2.65	2.65	3.20	3.20
TCO2Eq			—	1.789	1.789	2.160	2.160
GWP			—	675	675	675	675
Liquid/ Gas			mm(inch)	φ9.52/φ15.88(3/8"/5/8")	φ9.52/φ15.88(3/8"/5/8")	φ9.52/φ15.88(3/8"/5/8")	φ9.52/φ15.88(3/8"/5/8")
Refrigerant piping	Pipe length	Max. equivalent TI Climate	m	75	75	75	75
	Pipe length	Max. equivalent Full Range	m	50	50	60	60
		Max. (OD lower)	m	30	30	30	30
	Height difference	Max. (OD lower)	m	30	30	30	30
		Max. (OD higher)	m	30	30	30	30
	ADD Refrigerant AMOUNT	g/m	35	35	35	35	
	PIPE LENGTH FOR ADDITIONAL Refrigerant	m	7.5	7.5	7.5	7.5	
Operating Range (Outdoor)	Cooling	C	-15-52	-15-52	-15-52	-15-52	
	Heating	C	-20-24	-20-24	-20-24	-20-24	

# Ceiling Suspended

## Global LCAC Turbo Inverter R32 Inverter Expert

- WIFI Ready
- ON/OFF Function
- Emergency Use
- Anti-bacteria Fin
- Multiple Installation Types
- High Ceiling
- Easy Cleaning Filter
- Silver Ion Filter
- I Feel



EU model(Hisense)				AUV140UR4RC8	AUV140UR4RC8	AUV175UR4RC8
Indoor model				AUV-48UR4RC8	AUV-48UR4RC8	AUV-60UR4RC8
Seasonal efficiency	Cooling	Pdesignc	W	13500	13500	16000
		SEER	W/W	6.40	6.40	5.80
		ηs,c	100%	253%	253%	229%
		Energy Efficiency Class	—	NA	NA	NA
	Heating (Average Season)	Pdesignh	W	9000	9000	10000
		SCOP	W/W	4.40	4.40	3.80
		ηs,h	100%	173%	173%	149%
		Energy Efficiency Class	—	NA	NA	NA
	Heating (Warmer Season)	Pdesignh	W	9000	9000	10000
		SCOP	W/W	5.40	5.40	5.10
		ηs,h	100%	213%	213%	201%
		Energy Efficiency Class	—	NA	NA	NA
Cooling	Capacity	Nominal	Btu/h	46062	46062	54592
		Nominal	W	13500	13500	16000
		Min - Max	W	4400-15400	4400-15400	5000-18000
	EER	Nominal	W/W	3.21	3.21	2.65
Heating	Capacity	Nominal	Btu/h	54592	54592	59710
		Nominal	W	16000	16000	17500
		Min - Max	W	3800-17000	3800-17000	5000-21000
	COP	Nominal	W/W	3.30	3.30	3.30
Indoor unit	Dimension	W×H×D	mm	1580×680×230	1580×680×230	1580×680×230
	Weight	Net/Gross	kg	46/54	46/54	46/54
	Air Volume	Hi/Med/Lo	m³/h	2200/1900/1600	2200/1900/1600	2300/2000/1700
	Sound Level (SPL)	Hi/Med/Lo	dB(A)	56/51/48	56/51/48	57/52/49
	Sound Level (PWL)	Hi	dB(A)	71	71	72
	Sound Level (PWL)	Level	—	—	—	—

EU model(Hisense)				AUW140U4RW8	AUW140U6RW8	AUW175U6RW8
Outdoor model				AUW-48U4RW8	AUW-48U6RW8	AUW-60U6RW8
Outdoor unit	Dimension	W×H×D	mm	1100×875×450	1100×875×450	1100×875×450
	Weight	Net/Gross	kg	94/105	94/105	94/105
	Sound Level (SPL)	Hi	dB(A)	60	60	62
	Sound Level (PWL)	Hi	dB(A)	74	74	75
	Sound Level (PWL)	Level	—	—	—	—
	Refrigerant	Refrigerant	Type	—	R32	R32
Amount			kg	3.20	3.20	3.40
TCO2Eq			—	2.160	2.160	2.295
GWP			—	675	675	675
Liquid/ Gas			mm(inch)	φ9.52/φ15.88(3/8"/5/8")	φ9.52/φ15.88(3/8"/5/8")	φ9.52/φ15.88(3/8"/5/8")
Refrigerant piping	Pipe length	Max. equivalent TI Climate	m	75	75	85
	Pipe length	Max. equivalent Full Range	m	60	60	75
		Max. (OD lower)	m	30	30	30
	Height difference	Max. (OD lower)	m	30	30	30
		Max. (OD higher)	m	30	30	30
	ADD Refrigerant AMOUNT	g/m	35	35	35	
	PIPE LENGTH FOR ADDITIONAL Refrigerant	m	7.5	7.5	7.5	
Operating Range (Outdoor)	Cooling	C	-15-52	-15-52	-15-52	
	Heating	C	-20-24	-20-24	-20-24	

# Ceiling Suspended

## Global LCAC Super Inverter R32 Inverter Expert

- WIFI Ready
- ON/OFF Function
- Emergency Use
- Anti-bacteria Fin
- Multiple Installation Types
- High Ceiling
- Easy Cleaning Filter
- Silver Ion Filter
- I Feel

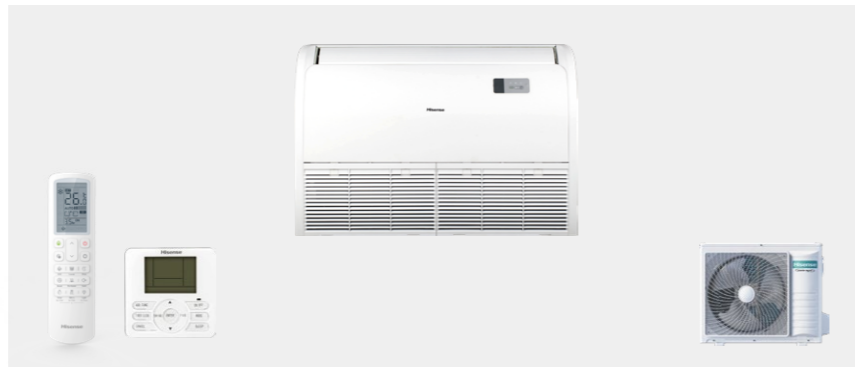

		EU model(Hisense)		AVT60UR4RB8	AVT71UR4RB8	AUV105UR4RC8
		Indoor model		AVT-21UR4RB8	AVT-24UR4RB8	AUV-36UR4RC8
Seasonal efficiency	Cooling	Pdesignc	W	6200	7000	9500
		SEER	W/W	6.70	6.30	6.10
		ηs,c	100%	316%	297%	287%
		Energy Efficiency Class	—	A++	A++	A++
	Heating (Average Season)	Pdesignh	W	5500	5500	8000
		SCOP	W/W	4.20	4.20	4.00
		ηs,h	100%	197%	197%	187%
		Energy Efficiency Class	—	A+	A+	A+
	Heating (Warmer Season)	Pdesignh	W	5500	5500	8000
		SCOP	W/W	5.35	5.35	5.31
		ηs,h	100%	252%	252%	250%
		Energy Efficiency Class	—	A+++	A+++	A+++
Cooling	Capacity	Nominal	Btu/h	21154	23884	32414
		Nominal	W	6200	7000	9500
	EER	Min - Max	W	2000-8000	2000-8500	2700-12000
		Nominal	W/W	3.41	3.24	2.85
Heating	Capacity	Nominal	Btu/h	24908	27296	37532
		Nominal	W	7300	8000	11000
	COP	Min - Max	W	2000-9000	2000-9500	2700-13000
		Nominal	W/W	3.80	3.72	3.40
Indoor unit	Dimension	W×H×D	mm	1285×680×230	1285×680×230	1580×680×230
	Weight	Net/Gross	kg	37/44	37/44	46/54
	Air Volume	Hi/Med/Lo	m³/h	1400/1200/1000	1400/1200/1000	1700/1500/1300
	Sound Level (SPL)	Hi/Med/Lo	dB(A)	50/46/42	50/46/42	56/51/48
	Sound Level (PWL)	Hi	dB(A)	62	62	65
	Sound Level (PWL)	Level	—	C	C	D

		EU model(Hisense)		AUW60U4RJ7	AUW71U4RJ7	AUW105U4RK7
		Outdoor model		AUW-21U4RJ7	AUW-24U4RJ7	AUW-36U4RK7
Outdoor unit	Dimension	W×H×D	mm	860×670×310	860×670×310	900×750×340
	Weight	Net/Gross	kg	44.5/48.5	44.5/48.5	55/59
	Sound Level (SPL)	Hi	dB(A)	57	57	58
	Sound Level (PWL)	Hi	dB(A)	68	68	69
	Sound Level (PWL)	Level	—	D	D	D
Refrigerant piping	Refrigerant	Type	—	R32	R32	R32
		Amount	kg	1.50	1.50	1.80
		TCO2Eq	—	1.013	1.013	1.215
	Liquid/ Gas	Amount	kg	1.50	1.50	1.80
		TCO2Eq	—	1.013	1.013	1.215
Operating Range (Outdoor)	Pipe length	Max. equivalent TI Climate	m	60	60	65
		Max. equivalent Full Range	m	45	45	50
	Height difference	Max. (OD lower)	m	30	30	30
		Max. (OD higher)	m	30	30	30
	ADD Refrigerant AMOUNT	g/m	35	35	35	
	PIPE LENGTH FOR ADDITIONAL Refrigerant	m	5	5	5	
	Operating Range (Outdoor)	Cooling	C	-15-48	-15-48	-15-48
Heating		C	-15-24	-15-24	-15-24	

# Console

## Global LCAC Turbo Inverter R32 Inverter Expert

- WIFI Ready
- ON/OFF Function
- Room Card Control
- Fire Leakage Control
- Up/ down Outlet
- Wired Controller
- Fours Directions For Pipeline
- Universal Unit
- HI-NANO

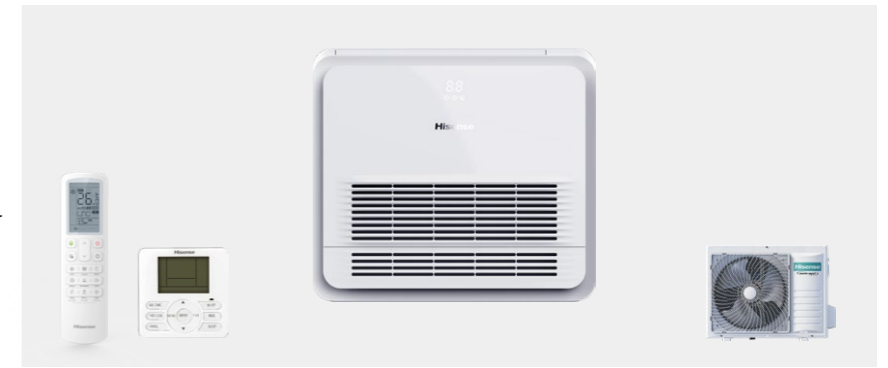

		EU model(Hisense)		AKT26UR4RK8	AKT35UR4RK8	AKT40UR4RK8	AKT52UR4RK8
		Indoor model		AKT-09UR4RK8	AKT-12UR4RK8	AKT-14UR4RK8	AKT-18UR4RK8
Seasonal efficiency	Cooling	Pdesignc	W	2600	3500	4100	4900
		SEER	W/W	7.10	7.00	7.00	7.00
		ηs,c	100%	335%	335%	330%	330%
		Energy Efficiency Class	—	A++	A++	A++	A++
	Heating (Average Season)	Pdesignh	W	3000	3000	3500	3500
		SCOP	W/W	4.35	4.35	4.40	4.40
		ηs,h	100%	204%	204%	207%	207%
		Energy Efficiency Class	—	A+	A+	A+	A+
	Heating (Warmer Season)	Pdesignh	W	3000	3000	3500	3500
		SCOP	W/W	5.35	5.35	5.35	5.35
		ηs,h	100%	252%	252%	252%	252%
		Energy Efficiency Class	—	A+++	A+++	A+++	A+++
Cooling	Capacity	Nominal	Btu/h	8871	11942	13989	16719
		Nominal	W	2600	3500	4100	4900
	EER	Min - Max	W	1300-3600	1300-4200	1500-6000	1500-6000
		Nominal	W/W	4.13	3.68	4.00	3.75
Heating	Capacity	Nominal	Btu/h	10918	13648	15354	17060
		Nominal	W	3200	4000	4500	5000
	COP	Min - Max	W	1300-4000	1300-5000	1500-6500	1500-7100
		Nominal	W/W	4.00	3.78	3.71	3.50
Indoor unit	Dimension	W×H×D	mm	700×630×220	700×630×220	700×630×220	700×630×220
	Weight	Net/Gross	kg	15/19	15/19	15/19	15/19
	Air Volume	Hi/Med/Lo	m³/h	600/510/440	600/510/440	700/600/470	700/600/470
	Sound Level (SPL)	Hi/Med/Lo	dB(A)	40/35/33	40/35/33	44/40/35	44/40/35
	Sound Level (PWL)	Hi	dB(A)	56	56	59	59
	Sound Level (PWL)	Level	—	C	C	C	C

		EU model(Hisense)		AUW26U4RS8	AUW35U4RS8	AUW40U4RJ8	AUW52U4RJ8
		Outdoor model		AUW-09U4RS8	AUW-12U4RS8	AUW-14U4RJ8	AUW-18U4RJ8
Outdoor unit	Dimension	W×H×D	mm	810×580×280	810×580×280	860×670×310	860×670×310
	Weight	Net/Gross	kg	34/38.5	34/38.5	44/48	44/48
	Sound Level (SPL)	Hi	dB(A)	51	51	49	49
	Sound Level (PWL)	Hi	dB(A)	62	62	64	64
	Sound Level (PWL)	Level	—	C	C	C	C
Refrigerant piping	Refrigerant	Type	—	R32	R32	R32	R32
		Amount	kg	0.87	0.87	1.20	1.20
		TCO2Eq	—	0.587	0.587	0.810	0.810
	Liquid/ Gas	Amount	kg	0.87	0.87	1.20	1.20
		TCO2Eq	—	0.587	0.587	0.810	0.810
Operating Range (Outdoor)	Pipe length	Max. equivalent TI Climate	m	35	35	55	55
		Max. equivalent Full Range	m	30	30	50	50
	Height difference	Max. (OD lower)	m	15	15	30	30
		Max. (OD higher)	m	15	15	30	30
	ADD Refrigerant AMOUNT	g/m	15	15	15	15	
	PIPE LENGTH FOR ADDITIONAL Refrigerant	m	5	5	5	5	
	Operating Range (Outdoor)	Cooling	C	-15-52	-15-52	-15-52	-15-52
Heating		C	-20-24	-20-24	-20-24	-20-24	

# Console

## Global LCAC Super Inverter R32 Inverter Expert

- WIFI Ready
- ON/OFF Function
- Room Card Control
- Fire Leakage Control
- Up/ down Outlet
- Wired Controller
- Fours Directions For Pipeline
- Universal Unit
- HI-NANO



EU model(Hisense)				AKT40UR4RK8	AKT52UR4RK8
Indoor model				AKT-14UR4RK8	AKT-18UR4RK8
Seasonal efficiency	Cooling	Pdesignc	W	4100	4900
		SEER	W/W	6.64	6.50
		ηs,c	100%	313%	307%
		Energy Efficiency Class	—	A++	A++
	Heating (Average Season)	Pdesignh	W	3500	3500
		SCOP	W/W	4.10	4.10
		ηs,h	100%	192%	192%
		Energy Efficiency Class	—	A+	A+
	Heating (Warmer Season)	Pdesignh	W	3500	3500
		SCOP	W/W	5.40	5.40
		ηs,h	100%	254%	254%
		Energy Efficiency Class	—	A+++	A+++
Cooling	Capacity	Nominal	Btu/h	13989	16719
		Nominal	W	4100	4900
	EER	Min - Max	W	1500-5000	1500-6000
		Nominal	W/W	3.80	3.31
Heating	Capacity	Nominal	Btu/h	15354	18766
		Nominal	W	4500	5500
	COP	Min - Max	W	1500-5500	1500-6500
		Nominal	W/W	3.54	3.50
Indoor unit	Dimension	W×H×D	mm	700×630×220	700×630×220
	Weight	Net/Gross	kg	15/19	15/19
	Air Volume	Hi/Med/Lo	m³/h	700/600/470	700/600/470
	Sound Level (SPL)	Hi/Med/Lo	dB(A)	44/40/35	44/40/35
	Sound Level (PWL)	Hi	dB(A)	59	59
	Sound Level (PWL)	Level	—	C	C

EU model(Hisense)				AUW40U4RS7	AUW52U4RS7
Outdoor model				AUW-14U4RS7	AUW-18U4RS7
Outdoor unit	Dimension	W×H×D	mm	810×580×280	810×580×280
	Weight	Net/Gross	kg	36/40	36/40
	Sound Level (SPL)	Hi	dB(A)	52	52
	Sound Level (PWL)	Hi	dB(A)	63	63
	Sound Level (PWL)	Level	—	C	C
	Refrigerant	Refrigerant	Type	—	R32
Amount			kg	1.08	1.08
TCO2Eq			—	0.729	0.729
GWP			—	675	675
Refrigerant piping	Liquid/ Gas	mm(inch)	φ6.35/φ12.7(1/4"/1/2")	φ6.35/φ12.7(1/4"/1/2")	
	Pipe length	Max. equivalent TI Climate	m	50	50
	Pipe length	Max. equivalent Full Range	m	40	40
	Height difference	Max. (OD lower)	m	30	30
		Max. (OD higher)	m	30	30
	ADD Refrigerant AMOUNT	g/m	15	15	
	PIPE LENGTH FOR ADDITIONAL Refrigerant	m	5	5	
Operating Range (Outdoor)	Cooling	C	-15~-48	-15~-48	
	Heating	C	-15~-24	-15~-24	

# Floor Standing

## Global LCAC Turbo Inverter R32 Inverter Expert

- Optional Healthy Filter
- 18m Long Distance Airflow
- Easy Clean Filter
- 4D Air Flow
- Bottom Lock
- Room Card Control
- ON/OFF Function
- WIFI Ready
- I Feel



EU model(Hisense)				AUF71UR4RCPA8	AUF105UR4RMPA8	AUF140UR4RMPA8	AUF175UR4RHPA8
Indoor model				AUF-24UR4RCPA8	AUF-36UR4RMPA8	AUF-48UR4RMPA8	AUF-60UR4RHPA8
Seasonal efficiency	Cooling	Pdesignc	W	7000	10000	13500	16000
		SEER	W/W	6.30	6.20	6.20	6.50
		ηs,c	100%	297%	292%	245%	257%
		Energy Efficiency Class	—	A++	A++	NA	NA
	Heating (Average Season)	Pdesignh	W	5500	7400	8500	10000
		SCOP	W/W	4.10	4.00	4.00	4.10
		ηs,h	100%	192%	187%	157%	161%
		Energy Efficiency Class	—	A+	A+	NA	NA
	Heating (Warmer Season)	Pdesignh	W	5500	7400	8500	10000
		SCOP	W/W	5.1	5.20	5.10	5.40
		ηs,h	100%	240%	245%	201%	213%
		Energy Efficiency Class	—	A+++	A+++	NA	NA
Cooling	Capacity	Nominal	Btu/h	23884	34120	46062	54592
		Nominal	W	7000	10000	13500	16000
	EER	Min - Max	W	2000-8500	3000-12000	3300-14500	5000-18000
		Nominal	W/W	3.21	3.21	2.90	3.00
Heating	Capacity	Nominal	Btu/h	27296	37532	49474	59710
		Nominal	W	8000	11000	14500	17500
	COP	Min - Max	W	2000-9500	3000-11800	3000-15000	5000-21000
		Nominal	W/W	3.72	3.72	3.54	3.80
Indoor unit	Dimension	W×H×D	mm	500×1760×280	580×1870×380	580×1870×380	665×1928×415
	Weight	Net/Gross	kg	31/38	50/61	50/61	57.5/70.5
	Air Volume	Hi/Med/Lo	m³/h	1240/1120/1000	1700/1550/1350	1750/1500/1300	2600/2400/2200
	Sound Level (SPL)	Hi/Med/Lo	dB(A)	49/46/43	51/48/45	52/46/44	56/54/52
	Sound Level (PWL)	Hi	dB(A)	61	61	63	70
	Sound Level (PWL)	Level	—	C	C	—	—

EU model(Hisense)				AUW71U4RJ7	AUW105U4RK7	AUW140U6RQ7	AUW175U6RW8
Outdoor model				AUW-24U4RJ7	AUW-36U4RK7	AUW-48U6RQ7	AUW-60U6RW8
Outdoor unit	Dimension	W×H×D	mm	860×670×310	900×750×340	975×835×360	1100×875×450
	Weight	Net/Gross	kg	44.5/48.5	58/61	75.5/84.5	94/105
	Sound Level (SPL)	Hi	dB(A)	57	58	61	62
	Sound Level (PWL)	Hi	dB(A)	68	69	75	75
	Sound Level (PWL)	Level	—	D	D	—	—
	Refrigerant	Refrigerant	Type	—	R32	R32	R32
Amount			kg	1.50	1.80	2.70	3.40
TCO2Eq			—	1.013	1.215	1.823	2.295
GWP			—	675	675	675	675
Refrigerant piping	Liquid/ Gas	mm(inch)	φ9.52/φ15.88(3/8"/5/8")	φ9.52/φ15.88(3/8"/5/8")	φ9.52/φ15.88(3/8"/5/8")	φ9.52/φ15.88(3/8"/5/8")	
	Pipe length	Max. equivalent TI Climate	m	60	65	65	85
	Pipe length	Max. equivalent Full Range	m	45	50	50	75
	Height difference	Max. (OD lower)	m	30	30	30	30
		Max. (OD higher)	m	30	30	30	30
	ADD Refrigerant AMOUNT	g/m	35	35	35	35	
	PIPE LENGTH FOR ADDITIONAL Refrigerant	m	5	5	7.5	7.5	
Operating Range (Outdoor)	Cooling	C	-15~-48	-15~-48	-15~-48	-15~-52	
	Heating	C	-15~-24	-15~-24	-15~-24	-20~-24	

# FUNCTIONS OVERVIEW



Function List	No.	EU Model(Hisense)				
		ACT26UR4RCC8	ACT35UR4RCC8	ACT40UR4RCC8	ACT52UR4RCC8	
		Factory Model				
		ACT-09UR4RCC8	ACT-12UR4RCC8	ACT-14UR4RCC8	ACT-18UR4RCC8	
Basic	1	Auto	●	●	●	●
	2	Cool	●	●	●	●
	3	Dry	●	●	●	●
	4	Fan	●	●	●	●
	5	Hot	●	●	●	●
Comfort	6	Anti-cold Air	●	●	●	●
	7	Auto Swing	●	●	●	●
	8	Faster Cooling	-	-	-	-
	9	Front Desk Control	-	-	-	-
	10	Louver Position Memory	-	-	-	-
	11	Multi Zoning	●	●	●	●
	12	Round Flow	●	●	●	●
	13	Sleep Mode	●	●	●	●
Efficiency	14	All DC (Full DC)	●	●	●	●
	15	Moter Hi-smart	●	●	●	●
	16	Timer-24h	●	●	●	●
Flexible	17	Duct Static Pressure Setting	-	-	-	-
	18	Easy Cardboard	●	●	●	●
	19	Easy Cleaning Filter	●	●	●	●
	20	Emergency Use	●	●	●	●
	21	Esp Self-adaptable	-	-	-	-
	22	High Ceiling Application (3m/4m)	●	●	●	●
	23	Long-term Filter	●	●	●	●
Healthy	24	Washable Filter	●	●	●	●
	25	Fresh Air Intake	●	●	●	●
	26	Healthy Drain Pan	-	-	-	-
	27	No Wet Fin	●	●	●	●
	28	Self-cleaning	●	●	●	●
	29	HI-NANO	Optional	Optional	Optional	Optional
Smart	30	0.1C Display/YXE-E0IU(E)	●	●	●	●
	31	8 C Special Heating	Optional	Optional	Optional	Optional
	32	Auto Restart	●	●	●	●
	33	BACnet Gateway	●	●	●	●
	34	C/F exchange	●	●	●	●
	35	Central Control	●	●	●	●
	36	Child Lock	●	●	●	●
	37	Deep Cool/infrastructure Cooling	-	-	●	●
	38	Display Switching	●	●	●	●
	39	Energy Consumption Monitor	●	●	●	●
	40	Error Alarm Port	●	●	●	●
	41	Error Code Display	●	●	●	●
	42	Filter Cleaning Remind	●	●	●	●
	43	Humidity Sensor	●	●	●	●
	44	I Feel	●	●	●	●
	45	Smart Eye	-	-	-	-
	46	Individual Airflow Control	●	●	●	●
	47	KNX Gateway	-	-	-	-
	48	On-Off Fire Alarm	●	●	●	●
	49	On-Off_All On/All Off	●	●	●	●
50	Setpoint Range Set	●	●	●	●	
Stability	51	Temperature Compensation	●	●	●	●
	52	Voice Command	●	●	●	●
	53	Weekly Schedule Timer	●	●	●	●
	54	Wifi Ready	●	●	●	●
	55	Wireless Remote Receive	●	●	●	●
	56	High-lift Pump	●	●	●	●
	57	Inner Pump Standard	●	●	●	●
	58	Modbus Gateway	●	●	●	●
	59	Outer Pump Optional	-	-	-	-
	60	Water Level Switch	●	●	●	●

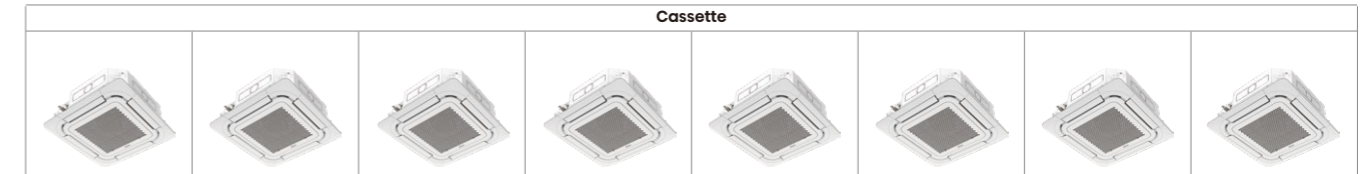

No.	Casette							
	ACT40UR4RJC8 AUC-14UR4RJC8	ACT52UR4RJC8 AUC-18UR4RJC8	ACT60UR4RJC8 ACT-21UR4RJC8	ACT71UR4RJC8 ACT-24UR4RJC8	AUC105UR4RKC8 AUC-36UR4RKC8	AUC125UR4RKC8 AUC-42UR4RKC8	AUC140UR4RKC8 AUC-48UR4RKC8	AUC175UR4RKC8 AUC-60UR4RKC8
1	●	●	●	●	●	●	●	●
2	●	●	●	●	●	●	●	●
3	●	●	●	●	●	●	●	●
4	●	●	●	●	●	●	●	●
5	●	●	●	●	●	●	●	●
6	●	●	●	●	●	●	●	●
7	●	●	●	●	●	●	●	●
8	-	-	-	-	-	-	-	-
9	-	-	-	-	-	-	-	-
10	-	-	-	-	-	-	-	-
11	●	●	●	●	●	●	●	●
12	●	●	●	●	●	●	●	●
13	●	●	●	●	●	●	●	●
14	●	●	●	●	●	●	●	●
15	●	●	●	●	●	●	●	●
16	●	●	●	●	●	●	●	●
17	-	-	-	-	-	-	-	-
18	●	●	●	●	●	●	●	●
19	●	●	●	●	●	●	●	●
20	-	-	-	-	-	-	-	-
21	-	-	-	-	-	-	-	-
22	●	●	●	●	●	●	●	●
23	●	●	●	●	●	●	●	●
24	●	●	●	●	●	●	●	●
25	●	●	●	●	●	●	●	●
26	●	●	●	●	●	●	●	●
27	●	●	●	●	●	●	●	●
28	●	●	●	●	●	●	●	●
29	Optional	Optional	Optional	Optional	Optional	Optional	Optional	Optional
30	●	●	●	●	●	●	●	●
31	Optional	Optional	Optional	Optional	Optional	Optional	Optional	Optional
32	●	●	●	●	●	●	●	●
33	●	●	●	●	●	●	●	●
34	●	●	●	●	●	●	●	●
35	●	●	●	●	●	●	●	●
36	●	●	●	●	●	●	●	●
37	●	●	●	●	●	●	●	●
38	●	●	●	●	●	●	●	●
39	●	●	●	●	●	●	●	●
40	●	●	●	●	●	●	●	●
41	●	●	●	●	●	●	●	●
42	●	●	●	●	●	●	●	●
43	●	●	●	●	●	●	●	●
44	●	●	●	●	●	●	●	●
45	Optional	Optional	Optional	Optional	Optional	Optional	Optional	Optional
46	●	●	●	●	●	●	●	●
47	-	-	-	-	-	-	-	-
48	●	●	●	●	●	●	●	●
49	●	●	●	●	●	●	●	●
50	●	●	●	●	●	●	●	●
51	●	●	●	●	●	●	●	●
52	●	●	●	●	●	●	●	●
53	●	●	●	●	●	●	●	●
54	●	●	●	●	●	●	●	●
55	●	●	●	●	●	●	●	●
56	●	●	●	●	●	●	●	●
57	●	●	●	●	●	●	●	●
58	●	●	●	●	●	●	●	●
59	-	-	-	-	-	-	-	-
60	●	●	●	●	●	●	●	●

# FUNCTIONS OVERVIEW



Function List	No.	EU Model(Hisense)	ADT26UX4RBL8	ADT35UX4RBL8	ADT40UX4RCL8	ADT52UX4RCL8	ADT71UX4RCL8
		Factory Model	ADT-09UX4RBL8	ADT-12UX4RBL8	ADT-14UX4RCL8	ADT-18UX4RCL8	ADT-24UX4RCL8
Basic	1	Auto	●	●	●	●	●
	2	Cool	●	●	●	●	●
	3	Dry	●	●	●	●	●
	4	Fan	●	●	●	●	●
	5	Hot	●	●	●	●	●
Comfort	6	Anti-cold Air	●	●	●	●	●
	7	Auto Swing	-	-	-	-	-
	8	Faster Cooling	-	-	-	-	-
	9	Front Desk Control	●	●	●	●	●
	10	Louver Position Memory	-	-	-	-	-
	11	Multi Zoning	●	●	●	●	●
	12	Round Flow	-	-	-	-	-
	13	Sleep Mode	●	●	●	●	●
Efficiency	14	All DC (Full DC)	●	●	●	●	●
	15	Moter Hi-smart	-	-	-	-	-
	16	Timer-24h	●	●	●	●	●
Flexible	17	Duct Static Pressure Setting	●	●	●	●	●
	18	Easy Cardboard	●	●	●	●	●
	19	Easy Cleaning Filter	●	●	●	●	●
	20	Emergency Use	-	-	-	-	-
	21	Esp Self-adaptable	-	-	-	-	-
	22	High Ceiling Application (3m/4m)	-	-	-	-	-
	23	Long-term Filter	●	●	●	●	●
Healthy	24	Washable Filter	●	●	●	●	●
	25	Fresh Air Intake	●	●	●	●	●
	26	Healthy Drain Pan	●	●	●	●	●
	27	No Wet Fin	●	●	●	●	●
	28	Self-cleaning	●	●	●	●	●
	29	HI-NANO	Optional	Optional	Optional	Optional	Optional
Smart	30	0.1℃ Display/YXE-E0IU(E)	●	●	●	●	●
	31	8℃ Special Heating	Optional	Optional	Optional	Optional	Optional
	32	Auto Restart	●	●	●	●	●
	33	BACnet Gateway	●	●	●	●	●
	34	C/F exchange	●	●	●	●	●
	35	Central Control	●	●	●	●	●
	36	Child Lock	●	●	●	●	●
	37	Deep Cool/infrastructure Cooling	-	-	●	●	●
	38	Display Switching	●	●	●	●	●
	39	Energy Consumption Monitor	●	●	●	●	●
	40	Error Alarm Port	●	●	●	●	●
	41	Error Code Display	●	●	●	●	●
	42	Filter Cleaning Remind	●	●	●	●	●
	43	Humidity Sensor	●	●	●	●	●
	44	I Feel	●	●	●	●	●
	45	Smart Eye	-	-	-	-	-
	46	Individual Airflow Control	-	-	-	-	-
	47	KNX Gateway	-	-	-	-	-
	48	On-Off Fire Alarm	●	●	●	●	●
	49	On-Off_All On/All Off	●	●	●	●	●
	50	Setpoint Range Set	●	●	●	●	●
	51	Temperature Compensation	●	●	●	●	●
	52	Voice Command	●	●	●	●	●
	53	Weekly Schedule Timer	●	●	●	●	●
	54	Wifi Ready	●	●	●	●	●
	55	Wireless Remote Receive	●	●	●	●	●
	Stability	56	High-lift Pump	●	●	●	●
57		Inner Pump Standard	●	●	●	●	●
58		Modbus Gateway	●	●	●	●	●
59		Outer Pump Optional	-	-	-	-	-
60		Water Level Switch	●	●	●	●	●

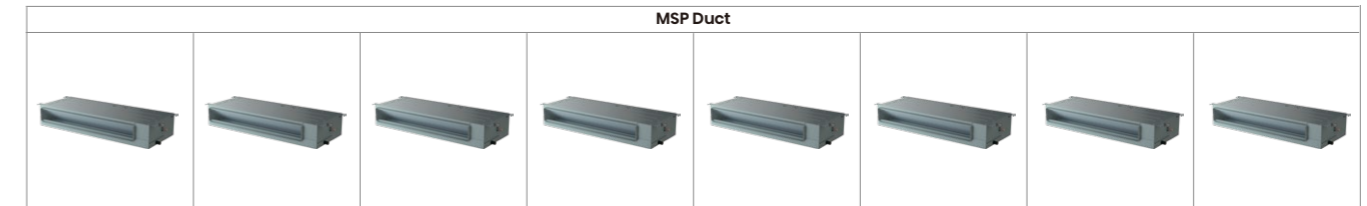

Function List	No.	EU Model(Hisense)	ADT40UX4RGM8	ADT52UX4RGM8	ADT60UX4RFM8	ADT71UX4RFM8	AUD90UX4RFM8	AUD105UX4RQM8	AUD125UX4RQM8	AUD140UX4RQM8
		Factory Model	ADT-14UX4RGM8	ADT-18UX4RGM8	ADT-21UX4RFM8	ADT-24UX4RFM8	AUD-30UX4RFM8	AUD-36UX4RQM8	AUD-42UX4RQM8	AUD-48UX4RQM8
Basic	1	Auto	●	●	●	●	●	●	●	●
	2	Cool	●	●	●	●	●	●	●	●
	3	Dry	●	●	●	●	●	●	●	●
	4	Fan	●	●	●	●	●	●	●	●
	5	Hot	●	●	●	●	●	●	●	●
Comfort	6	Anti-cold Air	●	●	●	●	●	●	●	●
	7	Auto Swing	-	-	-	-	-	-	-	-
	8	Faster Cooling	-	-	-	-	-	-	-	-
	9	Front Desk Control	●	●	●	●	●	●	●	●
	10	Louver Position Memory	-	-	-	-	-	-	-	-
	11	Multi Zoning	●	●	●	●	●	●	●	●
	12	Round Flow	-	-	-	-	-	-	-	-
	13	Sleep Mode	●	●	●	●	●	●	●	●
Efficiency	14	All DC (Full DC)	●	●	●	●	●	●	●	●
	15	Moter Hi-smart	-	-	-	-	-	-	-	-
	16	Timer-24h	●	●	●	●	●	●	●	●
Flexible	17	Duct Static Pressure Setting	●	●	●	●	●	●	●	●
	18	Easy Cardboard	●	●	●	●	●	●	●	●
	19	Easy Cleaning Filter	●	●	●	●	●	●	●	●
	20	Emergency Use	-	-	-	-	-	-	-	-
	21	Esp Self-adaptable	-	-	-	-	-	-	-	-
	22	High Ceiling Application (3m/4m)	-	-	-	-	-	-	-	-
	23	Long-term Filter	●	●	●	●	●	●	●	●
Healthy	24	Washable Filter	●	●	●	●	●	●	●	●
	25	Fresh Air Intake	●	●	●	●	●	●	●	●
	26	Healthy Drain Pan	●	●	●	●	●	●	●	●
	27	No Wet Fin	●	●	●	●	●	●	●	●
	28	Self-cleaning	●	●	●	●	●	●	●	●
	29	HI-NANO	Optional	Optional	Optional	Optional	Optional	Optional	Optional	Optional
Smart	30	0.1℃ Display/YXE-E0IU(E)	●	●	●	●	●	●	●	●
	31	8℃ Special Heating	Optional	Optional	Optional	Optional	Optional	Optional	Optional	Optional
	32	Auto Restart	●	●	●	●	●	●	●	●
	33	BACnet Gateway	●	●	●	●	●	●	●	●
	34	C/F exchange	●	●	●	●	●	●	●	●
	35	Central Control	●	●	●	●	●	●	●	●
	36	Child Lock	●	●	●	●	●	●	●	●
	37	Deep Cool/infrastructure Cooling	-	-	●	●	●	●	●	●
	38	Display Switching	●	●	●	●	●	●	●	●
	39	Energy Consumption Monitor	●	●	●	●	●	●	●	●
	40	Error Alarm Port	●	●	●	●	●	●	●	●
	41	Error Code Display	●	●	●	●	●	●	●	●
	42	Filter Cleaning Remind	●	●	●	●	●	●	●	●
	43	Humidity Sensor	●	●	●	●	●	●	●	●
	44	I Feel	●	●	●	●	●	●	●	●
	45	Smart Eye	-	-	-	-	-	-	-	-
	46	Individual Airflow Control	-	-	-	-	-	-	-	-
	47	KNX Gateway	-	-	-	-	-	-	-	-
	48	On-Off Fire Alarm	●	●	●	●	●	●	●	●
	49	On-Off_All On/All Off	●	●	●	●	●	●	●	●
	50	Setpoint Range Set	●	●	●	●	●	●	●	●
	51	Temperature Compensation	●	●	●	●	●	●	●	●
	52	Voice Command	●	●	●	●	●	●	●	●
	53	Weekly Schedule Timer	●	●	●	●	●	●	●	●
	54	Wifi Ready	●	●	●	●	●	●	●	●
	55	Wireless Remote Receive	●	●	●	●	●	●	●	●
	Stability	56	High-lift Pump	●	●	●	●	●	●	●
57		Inner Pump Standard	●	●	●	●	●	●	●	●
58		Modbus Gateway	●	●	●	●	●	●	●	●
59		Outer Pump Optional	-	-	-	-	-	-	-	-
60		Water Level Switch	●	●	●	●	●	●	●	●

# FUNCTIONS OVERVIEW

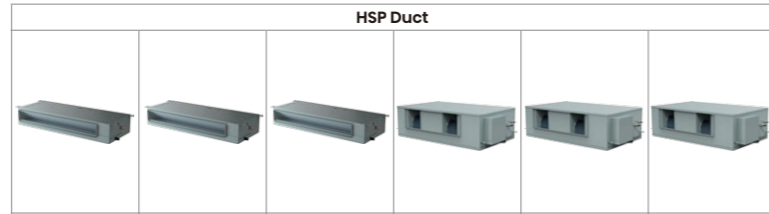

Function List	No.	EU Model(Hisense)		HSP Duct					
		Factory Model	AUD10SUX4REH8	AUD12SUX4REH8	AUD140UX4REH8	AUD175UX4REH8	AUD200UX4RPH8	AUD250UX4RPH8	
Basic	1	Auto	●	●	●	●	●	●	
	2	Cool	●	●	●	●	●	●	
	3	Dry	●	●	●	●	●	●	
	4	Fan	●	●	●	●	●	●	
	5	Hot	●	●	●	●	●	●	
Comfort	6	Anti-cold Air	●	●	●	●	●	●	
	7	Auto Swing	-	-	-	-	-	-	
	8	Faster Cooling	-	-	-	-	-	-	
	9	Front Desk Control	-	-	-	-	-	-	
	10	Louver Position Memory	-	-	-	-	-	-	
	11	Multi Zoning	●	●	●	●	●	●	
	12	Round Flow	-	-	-	-	-	-	
	13	Sleep Mode	●	●	●	●	●	●	
Efficiency	14	All DC (Full DC)	●	●	●	●	●	●	
	15	Moter Hi-smart	●	●	●	●	●	-	
	16	Timer-24h	●	●	●	●	●	●	
Flexible	17	Duct Static Pressure Setting	●	●	●	●	●	●	
	18	Easy Cardboard	●	●	●	●	●	●	
	19	Easy Cleaning Filter	●	●	●	●	●	●	
	20	Emergency Use	-	-	-	-	-	-	
	21	Esp Self-adaptable	-	-	-	-	-	-	
	22	High Ceiling Application (3m/4m)	-	-	-	-	-	-	
	23	Long-term Filter	●	●	●	●	●	●	
	24	Washable Filter	●	●	●	●	●	●	
Healthy	25	Fresh Air Intake	●	●	●	●	●	●	
	26	Healthy Drain Pan	●	●	●	●	●	●	
	27	No Wet Fin	●	●	●	●	●	●	
	28	Self-cleaning	●	●	●	●	●	●	
	29	HI-NANO	Optional	Optional	Optional	Optional	Optional	Optional	
Smart	30	0.1℃ Display/YXE-E01U(E)	●	●	●	●	●	●	
	31	8℃ Special Heating	Optional	Optional	Optional	Optional	Optional	Optional	
	32	Auto Restart	●	●	●	●	●	●	
	33	BACnet Gateway	●	●	●	●	●	●	
	34	C/F exchange	●	●	●	●	●	●	
	35	Central Control	●	●	●	●	●	●	
	36	Child Lock	●	●	●	●	●	●	
	37	Deep Cool/infrastructure Cooling	●	●	●	●	●	●	
	38	Display Switching	●	●	●	●	●	●	
	39	Energy Consumption Monitor	●	●	●	●	●	●	
	40	Error Alarm Port	●	●	●	●	●	●	
	41	Error Code Display	●	●	●	●	●	●	
	42	Filter Cleaning Remind	●	●	●	●	●	●	
	43	Humidity Sensor	●	●	●	●	●	●	
	44	I Feel	●	●	●	●	●	●	
	45	Smart Eye	-	-	-	-	-	-	
	46	Individual Airflow Control	-	-	-	-	-	-	
	47	KNX Gateway	-	-	-	-	-	-	
	48	On-Off Fire Alarm	●	●	●	●	●	●	
	49	On-Off_All On/All Off	●	●	●	●	●	●	
	50	Setpoint Range Set	●	●	●	●	●	●	
	51	Temperature Compensation	●	●	●	●	●	●	
	52	Voice Command	●	●	●	●	●	●	
	53	Weekly Schedule Timer	●	●	●	●	●	●	
	54	Wifi Ready	●	●	●	●	●	●	
	55	Wireless Remote Receive	●	●	●	●	●	●	
	Stability	56	High-lift Pump	●	●	●	●	●	●
57		Inner Pump Standard	●	●	●	●	●	●	
58		Modbus Gateway	●	●	●	●	●	●	
59		Outer Pump Optional	-	-	-	-	-	-	
60		Water Level Switch	●	●	●	●	●	●	

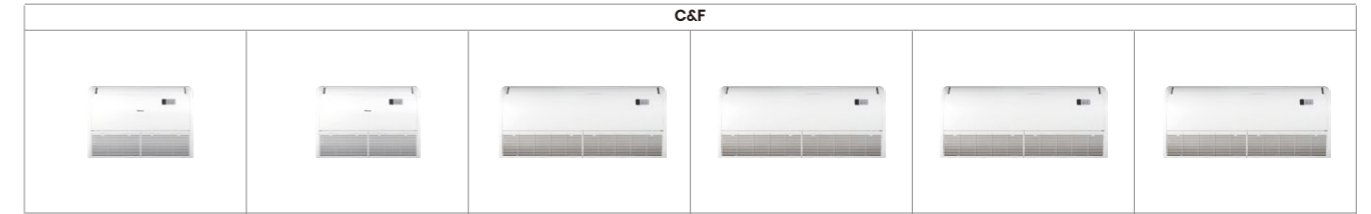

No.	C&F					
	AVT60UR4RB8 AUV-21UR4RB8	AVT71UR4RB8 AUV-24UR4RB8	AUV105UR4RC8 AUV-36UR4RC8	AUV125UR4RC8 AUV-42UR4RC8	AUV140UR4RC8 AUV-48UR4RC8	AUV175UR4RC8 AUV-60UR4RC8
1	●	●	●	●	●	●
2	●	●	●	●	●	●
3	●	●	●	●	●	●
4	●	●	●	●	●	●
5	●	●	●	●	●	●
6	●	●	●	●	●	●
7	●	●	●	●	●	●
8	-	-	-	-	-	-
9	-	-	-	-	-	-
10	●	●	●	●	●	●
11	-	-	-	-	-	-
12	-	-	-	-	-	-
13	●	●	●	●	●	●
14	●	●	●	●	●	●
15	-	-	-	-	-	-
16	●	●	●	●	●	●
17	-	-	-	-	-	-
18	●	●	●	●	●	●
19	●	●	●	●	●	●
20	●	●	●	●	●	●
21	-	-	-	-	-	-
22	●	●	●	●	●	●
23	●	●	●	●	●	●
24	●	●	●	●	●	●
25	●	●	●	●	●	●
26	●	●	●	●	●	●
27	●	●	●	●	●	●
28	●	●	●	●	●	●
29	-	-	-	-	-	-
30	●	●	●	●	●	●
31	Optional	Optional	Optional	Optional	Optional	Optional
32	●	●	●	●	●	●
33	●	●	●	●	●	●
34	●	●	●	●	●	●
35	●	●	●	●	●	●
36	●	●	●	●	●	●
37	●	●	●	●	●	●
38	●	●	●	●	●	●
39	●	●	●	●	●	●
40	●	●	●	●	●	●
41	●	●	●	●	●	●
42	●	●	●	●	●	●
43	-	-	-	-	-	-
44	●	●	●	●	●	●
45	-	-	-	-	-	-
46	-	-	-	-	-	-
47	-	-	-	-	-	-
48	●	●	●	●	●	●
49	●	●	●	●	●	●
50	●	●	●	●	●	●
51	●	●	●	●	●	●
52	●	●	●	●	●	●
53	●	●	●	●	●	●
54	●	●	●	●	●	●
55	●	●	●	●	●	●
56	●	●	●	●	●	●
57	-	-	-	-	-	-
58	●	●	●	●	●	●
59	Optional	Optional	Optional	Optional	Optional	Optional
60	-	-	-	-	-	-

# FUNCTIONS OVERVIEW

Console



Function List	No.	EU Model(Hisense)	AKT26UR4RK8	AKT35UR4RK8	AKT40UR4RK8	AKT52UR4RK8
		Factory Model	AKT-09UR4RK8	AKT-12UR4RK8	AKT-14UR4RK8	AKT-18UR4RK8
Basic	1	Auto	●	●	●	●
	2	Cool	●	●	●	●
	3	Dry	●	●	●	●
	4	Fan	●	●	●	●
	5	Hot	●	●	●	●
Comfort	6	Anti-cold Air	●	●	●	●
	7	Auto Swing	●	●	●	●
	8	Faster Cooling	-	-	-	-
	9	Front Desk Control	-	-	-	-
	10	Louver Position Memory	-	-	-	-
	11	Multi Zoning	-	-	-	-
	12	Round Flow	-	-	-	-
	13	Sleep Mode	●	●	●	●
Efficiency	14	All DC (Full DC)	●	●	●	●
	15	Moter Hi-smart	-	-	-	-
	16	Timer-24h	●	●	●	●
Flexible	17	Duct Static Pressure Setting	-	-	-	-
	18	Easy Cardboard	●	●	●	●
	19	Easy Cleaning Filter	●	●	●	●
	20	Emergency Use	-	-	-	-
	21	Esp Self-adaptable	-	-	-	-
	22	High Ceiling Application (3m/4m)	-	-	-	-
	23	Long-term Filter	-	-	-	-
Healthy	24	Washable Filter	●	●	●	●
	25	Fresh Air Intake	●	●	●	●
	26	Healthy Drain Pan	●	●	●	●
	27	No Wet Fin	●	●	●	●
	28	Self-cleaning	●	●	●	●
	29	HI-NANO	Optional	Optional	Optional	Optional
Smart	30	0.1℃ Display/YXE-E01U(E)	●	●	●	●
	31	8℃ Special Heating	Optional	Optional	Optional	Optional
	32	Auto Restart	●	●	●	●
	33	BACnet Gateway	●	●	●	●
	34	C/F exchange	●	●	●	●
	35	Central Control	●	●	●	●
	36	Child Lock	●	●	●	●
	37	Deep Cool/infrastructure Cooling	-	-	-	-
	38	Display Switching	●	●	●	●
	39	Energy Consumption Monitor	●	●	●	●
	40	Error Alarm Port	●	●	●	●
	41	Error Code Display	●	●	●	●
	42	Filter Cleaning Remind	●	●	●	●
	43	Humidity Sensor	●	●	●	●
	44	I Feel	●	●	●	●
	45	Smart Eye	-	-	-	-
	46	Individual Airflow Control	-	-	-	-
	47	KNX Gateway	-	-	-	-
	48	On-Off Fire Alarm	●	●	●	●
	49	On-Off_All On/All Off	●	●	●	●
	50	Setpoint Range Set	●	●	●	●
	51	Temperature Compensation	●	●	●	●
	52	Voice Command	●	●	●	●
	53	Weekly Schedule Timer	●	●	●	●
	54	Wifi Ready	●	●	●	●
	55	Wireless Remote Receive	●	●	●	●
	Stability	56	High-lift Pump	-	-	-
57		Inner Pump Standard	-	-	-	-
58		Modbus Gateway	●	●	●	●
59		Outer Pump Optional	-	-	-	-
60		Water Level Switch	-	-	-	-

Floor Standing

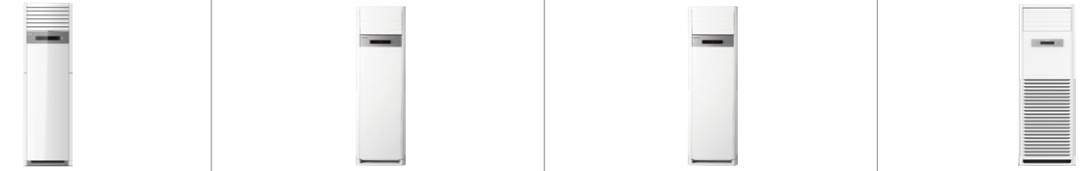

No.	AUF71UR4RCPA8	AUF105UR4RMPA8	AUF140UR4RMPA8	AUF175UR4RHPA8
	AUF-24UR4RCPA8	AUF-36UR4RMPA8	AUF-48UR4RMPA8	AUF-60UR4RHPA8
1	●	●	●	●
2	●	●	●	●
3	●	●	●	●
4	●	●	●	●
5	●	●	●	●
6	●	●	●	●
7	●	●	●	●
8	-	-	-	-
9	-	-	-	-
10	-	-	-	-
11	-	-	-	-
12	-	-	-	-
13	●	●	●	●
14	●	●	●	●
15	●	●	●	●
16	●	●	●	●
17	-	-	-	-
18	-	-	-	-
19	●	●	●	●
20	-	-	-	-
21	-	-	-	-
22	-	-	-	-
23	●	●	●	●
24	●	●	●	●
25	-	-	-	-
26	-	-	-	-
27	●	●	●	●
28	●	●	●	●
29	-	-	-	-
30	●	●	●	●
31	Optional	Optional	Optional	Optional
32	●	●	●	●
33	●	●	●	●
34	●	●	●	●
35	●	●	●	●
36	●	●	●	●
37	●	●	-	●
38	●	●	●	●
39	●	●	●	●
40	●	●	●	●
41	●	●	●	●
42	●	●	●	●
43	-	-	-	-
44	●	●	●	●
45	-	-	-	-
46	-	-	-	-
47	-	-	-	-
48	●	●	●	●
49	●	●	●	●
50	●	●	●	●
51	●	●	●	●
52	●	●	●	●
53	●	●	●	●
54	●	●	●	●
55	●	●	●	●
56	-	-	-	-
57	-	-	-	-
58	●	●	●	●
59	-	-	-	-
60	-	-	-	-

## Basic

- Auto**  
Auto mode can be realized by remote controller or wired controller.
- Fan**  
Fan mode can be realized by remote controller or wired controller.
- Cool**  
Cooling mode can be realized by the remote controller or the wired controller.
- Hot**  
Heating mode can be realized by remote controller or wired controller.
- Dry**  
Dehumidifying mode can be realized by remote controller or wired controller.

## Comfort

- Anti-Cold Air**  
Prevent the cold air from blowing out during air conditioning heating. Once the heating function is turned on, enjoy the warmth immediately.
- Louver Position Memory**  
The panel louver restarts automatically at the original settings after power failure.
- Auto Swing**  
Auto swing improve distribution of cooling, make you feel more comfortable.
- Multi Zoning**  
Allows up to XX individual climate zones with one indoor unit.
- Faster Cooling**  
Achieve fast cooling with high running frequency compressor, powerful fan, advanced air duct, heat-exchange system.
- Round Flow**  
"Round air supply optimizes room airflow, ensure the comfortable airflow goes to every corner and the temperature perfectly balance the integral space."
- Front Desk Control**  
The 3D airflow panel can offer even airflow and wide airflow coverage to keep every corners of your room cool or warm.
- Sleep Mode**  
Press the SLEEP button, and the operation mode changes from adult SLEEP, elderly SLEEP, youth SLEEP and children SLEEP to closed SLEEP mode. Adjust the temperature curve according to different SLEEP modes. The temperature curve is customized within 8 hours according to the needs of different groups of people.

## Efficiency

- All DC (Full DC)**  
DC compressor + DC indoor & outdoor motors + EXV.
- Timer-24h**  
Set a specific time during the day to have the AC automatically turn on or off.
- Moter Hi-Smart**  
Advanced inverter technology makes Hisense the inverter expert.

## Flexible

- Duct Static Pressure Setting**  
It is possible to adjust the ESP setting via wired controller. And the precision of 1 Pa can give the most accurate ESP setting in class.
- ESP Self-adaptable**  
The ESP accuracy of 1 Pa provides the most flexible adjustment of ESP to ensure a suitable environment conditions.
- Easy Cardboard**  
Guide Cardboard makes it easy to install hook of the indoor unit.
- High Ceiling Application (3m/4m)**  
The wired controller can be used to adjust the airflow according to the installation height and ensure that cool air blows down to people's activity area.
- Easy Cleaning Filter**  
The filter can be easily taken out, and easy to install.
- Long-term Filter**  
By using a long-acting filter screen, avoid frequent filter cleaning.
- Emergency Use**  
Emergency Key can be used to start the AC when the remote controller or wired controller doesn't work.
- Washable Filter**  
The filter can be cleaned for repeated use.

## Healthy

- Fresh Air Intake**  
"Fresh air intake interface is reserved on the side panel, which can be connected to air duct to introduce fresh air into the room with fresh air intake function, the indoor air is fresh and healthy."
- No Wet Fin**  
After turning off the AC, the indoor fan will continue running for 30 seconds, the evaporator and other parts of the indoor unit will be blown dry, prevent mildew growth.
- Healthy Drain Pan**  
Antibacterial Module can effectively purify condensed water and provide more healthy air supply.
- Self-Cleaning**  
Self-clean technology of evaporator can keep your air conditioner clean and reduce bacteria, microorganisms, oil stains and so on, via a frosting and defrosting cycle.

## Smart

- 0.1°C Display/YXE-E01U(E)**  
0.1°C display and 0.5°C control can be realized.
- Humidity Sensor**  
In dry mode, the room relative humidity can be displayed by wired controller.
- 8°C Special Heating**  
During absence, the indoor temperature can be maintained at a certain level.
- I Feel**  
The remote control is equipped with a temperature sensor to feel 1m with in the surrounding temperature.
- Auto Restart**  
The unit restarts automatically at the original settings after power failure.
- Smart Eye**  
With high-precision people sensing function, AIR FOLLOW YOU and AIR AVOID YOU can be realized.
- BACnet Gateway**  
The indoor unit can be connected to BMS system of the BAC net protocol by coordinating with B544E communication box.
- Individual Airflow Control**  
Each deflector can be controlled separately by a wired controller.
- °C/°F Exchange**  
Celsius and Fahrenheit can be converted to each other to meet different needs.
- KNX Gateway**  
The indoor unit can be connected to BMS system of the KNX protocol by coordinating with B545E communication box.
- Central Control**  
Central Control can be realized with the help of central controller and communication box.
- On-Off Fire Alarm**  
With the fire control, the A/C will be turned OFF automatically when the smoke detector alarm is activated.
- Child Lock**  
By setting the key lock, effectively avoid misoperation setting.
- On-Off\_All On/All Off**  
A kind of special control mode to achieve the control of indoor unit startup & shutdown based on the input state of the fire protection port of the indoor unit and output the fault status of indoor unit through OUT INPUT port.
- Deep Cool/Infrastructure Cooling**  
"Remove in a reliable, efficient and flexible way the heat constantly generated by the IT and server equipment to ensure maximum uptime while offering the best return on investment."
- Setpoint Range Set**  
The setting of temperature range can be modified by the wired controller (manual modification can be realized).
- Display Switching**  
The wired controller can be set to display ambient temperature and set temperature.
- Temperature Compensation**  
The ambient temperature monitored by the AC can be modified by the wired controller (Manual adjustment after the initial test).
- Energy Consumption Monitor**  
Power consumption can display on the CONNECT LIFE APP. (The user can check the power consumption on the APP)
- Voice Command**  
When the air conditioner is connected to Wi-Fi through the Hisense module, you can control the air conditioner by voice via Amazon or Google speakers.
- Error Alarm Port**  
When failure occurs, PCB port will output 12VDC signal for alarm (it highlights remote alarm, 12VDC can be linked to alarm lights, also alarm bells can be installed. Competitors use alarm bells)
- Weekly Schedule Timer**  
Timer can be set to start operation anytime on a daily or weekly basis.
- Error Code Display**  
We can identify the Error code through the panel display. When there is an error, the error code will flash. It is easier for us to troubleshoot.
- Wifi Ready**  
The product is equipped with WIFI port. When WIFI function is needed, customers can purchase WIFI module.
- Filter Cleaning Remind**  
If the AC runs for a long time, it will remind the user of cleaning the filter.
- Wireless Remote Receive**  
The wired controller can receive the control signal sent by the remote controller.

## Stability

- High-lift Pump**  
The maximum lift of Hisense high lift pump components can be as high as 1400mm.
- Outer Pump Optional**  
External water pump to drain the condensate water.
- Inner Pump Standard**  
Inner water pump to drain the condensate water.
- Water Level Switch**  
The float switch can ensure the water always under the safety level, even if the pump failed or the drain is blocked.
- Modbus Gateway**  
The indoor unit can be connected to BMS system of the Modbus protocol by coordinating with B544E communication box.

# FUNCTIONS OVERVIEW

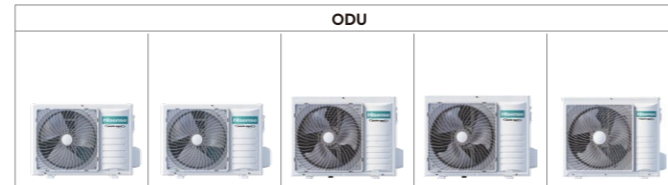

Function List	No.	EU Model(Hisense)				
		AUW26U4RS8	AUW35U4RS8	AUW40U4RJ8	AUW52U4RJ8	AUW60U4RK8
		Factory Model				
		AUW-09U4RS8	AUW-12U4RS8	AUW-14U4RJ8	AUW-18U4RJ8	AUW-21U4RK8
Efficiency	1	1W Standby	-	-	-	-
	2	Moter Hi-Smart	●	●	●	●
	3	Twin Rotary Compressor	●	●	●	●
Flexible	4	Charging Valve	-	-	-	-
	5	Hi-Checker	●	●	●	●
	6	Night Noise Control	●	●	●	●
	7	refrigerant Precharged	5m	5m	5m	5m
	8	Service Window-7 Segment Display	●	●	●	●
	9	Stop Valve Inside	-	-	-	-
	10	Twin, Triple, Double Twin	-	-	-	-
	11	Two Pipe Evacuation	-	-	-	●
Smart	12	intelligent defrost	●	●	●	●
	13	Service Window-Cooling Only	●	●	●	●
	14	Service Window-Energy Management	●	●	●	●
	15	Service Window-Foreced Defrost	●	●	●	●
	16	Service Window-Pump Down	●	●	●	●
Stability	17	3-minute Protection	●	●	●	●
	18	Compressor Heating Belt	●	●	●	●
	19	High Pressure Protection	-	-	-	-
	20	Leakage Detection	●	●	●	●
	21	Long Pipe	50	50	50	50
	22	Low Pressure Protection	-	-	-	-
	23	Low Voltage(176V)	●	●	●	●
	24	Low Voltage(198V)	●	●	●	●
	25	Low-Ambient Cooling (-15)	●	●	●	●
	26	Low-Ambient Heatling (-20)	●	●	●	●
	27	Bottom E-heater	Optional	Optional	Optional	Optional
	28	PCB with Insect Prevention	●	●	●	●
	29	Refrigerant cooled PCB	-	-	-	-

## Efficiency

**1W Standby**  
Ultra-low Energy Consumption, Effective Power Saving.

**Twin Rotary Compressor**  
Twin rotary compressor has less noise and vibration.

**Moter Hi-Smart**  
Advanced inverter technology makes Hisense the inverter expert. Better energy efficiency with external motor drive technology.

## Smart

**Intelligent Defrost**  
The optimized defrosting logics ensures better heating capacity and cleaner defrosting.

**Service Window-Foreced Defrost**  
By setting DIP, the AC will run in defrosting mode.

**Service Window-Cooling Only**  
By setting DIP, lock the unit, so it can not run in heating mode.

**Service Window-Pump Down**  
Recovering the refrigerant to the outdoor unit.

**Service Window-Energy Management**  
By setting DIP, limit the maximum power input and decrease the outdoor noise.

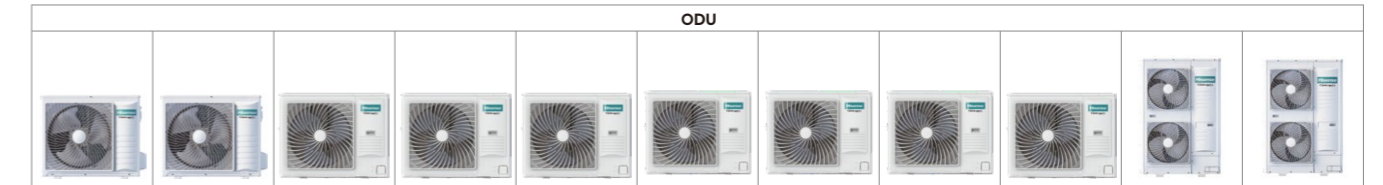

Function List	No.	EU Model(Hisense)										
		AUW71U4RK8	AUW90U4RK8	AUW105U4RW8	AUW125U4RW8	AUW140U4RW8	AUW105U6RW8	AUW125U6RW8	AUW140U6RW8	AUW175U6RW8	AUW200U6RZ8	AUW250U6RZ8
		Factory Model										
		AUW-24U4RK8	AUW-30U4RK8	AUW-36U4RW8	AUW-42U4RW8	AUW-48U4RW8	AUW-36U6RW8	AUW-42U6RW8	AUW-48U6RW8	AUW-60U6RW8	AUW-75U6RZ8	AUW-85U6RZ8
Efficiency	1	-	-	-	-	-	-	-	-	-	-	-
	2	●	●	●	●	●	●	●	●	●	●	●
	3	●	●	●	●	●	●	●	●	●	●	●
Flexible	4	-	-	●	●	●	●	●	●	●	●	●
	5	●	●	●	●	●	●	●	●	●	●	●
	6	●	●	●	●	●	●	●	●	●	●	●
	7	5m	5m	7.5m	7.5m	7.5m	7.5m	7.5m	7.5m	7.5m	7.5m	7.5m
	8	●	●	●	●	●	●	●	●	●	●	●
	9	-	-	●	●	●	●	●	●	●	●	●
	10	●	-	●	●	●	●	●	●	●	●	●
	11	●	●	●	●	●	●	●	●	●	●	●
Smart	12	●	●	●	●	●	●	●	●	●	●	●
	13	●	●	●	●	●	●	●	●	●	●	●
	14	●	●	●	●	●	●	●	●	●	●	●
	15	●	●	●	●	●	●	●	●	●	●	●
	16	●	●	●	●	●	●	●	●	●	●	●
Stability	17	●	●	●	●	●	●	●	●	●	●	●
	18	●	●	●	●	●	●	●	●	●	●	●
	19	-	-	●	●	●	●	●	●	●	●	●
	20	●	●	●	●	●	●	●	●	●	●	●
	21	50	50m	50	60	60	50	60	60	75	75	75
	22	-	-	●	●	●	●	●	●	●	●	●
	23	●	●	-	-	-	-	-	-	-	-	-
	24	●	●	●	●	●	●	●	●	●	●	●
	25	●	●	●	●	●	●	●	●	●	●	●
	26	●	●	●	●	●	●	●	●	●	●	●
	27	Optional	Optional	Optional	Optional	Optional	Optional	Optional	Optional	Optional	Optional	Optional
	28	●	●	●	●	●	●	●	●	●	-	-
	29	-	-	-	-	-	-	-	-	-	●	●

## Flexible

**Charging Valve**  
The charging valve makes after-sales service easier.

**Service Window-7 Segment Display**  
The fault code and AC running parameters will show on the 7-segment display.

**Hi-Checker**  
The AC can connect to Hi-Checker to monitor the product parameters, including discharge temperature, indoor coil temperature, outdoor coil temperature, etc.

**Stop Valve Inside**  
The new built-in design, it can realize 4 way pipe connection.

**Night Noise Control**  
By setting DIP, can reduce the noise of the ODU operation, to ensure the outdoor silence when sleep at night.

**Twin, Triple, Double Twin**  
2, 3 or 4 indoor units can be connected to only 1 outdoor unit. All indoor units operate within the same mode (cooling or heating) from one remote control.

**Refrigerant Precharged**  
Up to 80% LCAC project can be installed without additional refrigerant charge.

**Two Pipe Evacuation**  
The double 3-way stop valves, not matter built inside or outside, can help to vacuum fast.

# FUNCTIONS OVERVIEW

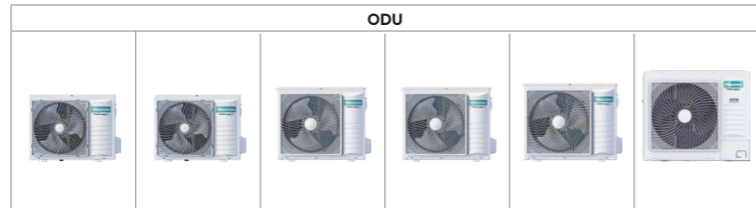

Function List	No.	EU Model(Hisense)	ODU					
		Factory Model	AUW40U4RS7	AUW52U4RS7	AUW60U4RJ7	AUW71U4RJ7	AUW105U4RK7	AUW140U6RQ7
Efficiency	1	1W Standby	-	-	-	-	-	-
	2	Moter Hi-Smart	●	●	●	●	●	●
	3	Twin Rotary Compressor	●	●	●	●	●	●
Flexible	4	Charging Valve	-	-	-	-	-	●
	5	HI-Checker	●	●	●	●	●	●
	6	Night Noise Control	●	●	●	●	●	●
	7	refrigerant Precharged	5m	5m	5m	5m	5m	5m
	8	Service Window-7 Segment Display	●	●	●	●	●	●
	9	Stop Valve Inside	-	-	-	-	-	-
	10	Twin, Triple, Double Twin	-	-	-	-	-	-
	11	Two Pipe Evacuation	-	-	●	●	●	●
Smart	12	intelligent defrost	●	●	●	●	●	●
	13	Service Window-Cooling Only	●	●	●	●	●	●
	14	Service Window-Energy Management	●	●	●	●	●	●
	15	Service Window-Forced Defrost	●	●	●	●	●	●
	16	Service Window-Pump Down	●	●	●	●	●	●
Stability	17	3-minute Protection	●	●	●	●	●	●
	18	Compressor Heating Belt	●	●	●	●	●	●
	19	High Pressure Protection	-	-	-	-	-	●
	20	Leakage Detection	●	●	●	●	●	●
	21	Long Pipe	40	40	45	45	50	50
	22	Low Pressure Protection	-	-	-	-	-	●
	23	Low Voltage(176V)	●	●	●	●	●	●
	24	Low Voltage(198V)	●	●	●	●	●	●
	25	Low-Ambient Cooling (-15)	●	●	●	●	●	●
	26	Low-Ambient Heatling (-20)	-	-	-	-	-	-
	27	Bottom E-heater	Optional	Optional	Optional	Optional	Optional	Optional
	28	PCB with Insect Prevention	●	●	●	●	●	●
	29	Refrigerant cooled PCB	-	-	-	-	-	-

## Stability

- 3-minute Protection**  
When the AC stops running by accident, the compressor will restart after 3 minutes to balance the system.
- Compressor Heating Belt**  
AC with compressor electric belt can still run stably in frigid regions.
- High Pressure Protection**  
The outdoor unit is equipped with a high-voltage switch to ensure the product reliability.
- Leakage Detection**  
The AC can detect and alert the refrigerant leakage if it occurs by monitoring the parameter abnormality.
- Long Pipe**  
the ACs With high installation flexibility.
- Low Pressure Protection**  
The outdoor unit is equipped with a low-voltage switch to ensure the product reliability.
- Low Voltage(176V)**  
The AC can still run stably even when the voltage is low to 176V.
- Low Voltage(198V)**  
The AC can still run stably even when the voltage is low to 198V.
- Low-Ambient Cooling (-15)**  
The unit can operate low to -15°C in cooling mode.
- Low-Ambient Heatling (-20)**  
The unit can operate low to -20°C in heating mode.
- Bottom E-heater**  
AC with bottom plate electric belt can prevent the bottom pate from freezing in winter.
- PCB with Insect Prevention**  
The structure of PCB prevents insects from entering.
- Refrigerant cooled PCB**  
Hisense uses refrigerant cooling technology to cool the electrical control box. It overcomes the poor heat dissipation and high ambient temperature issues to maintain efficient operation even at harsh environment.

# TECHNICAL DRAWINGS

DETAILED TECHNICAL DRAWINGS

## I Compact Cassette

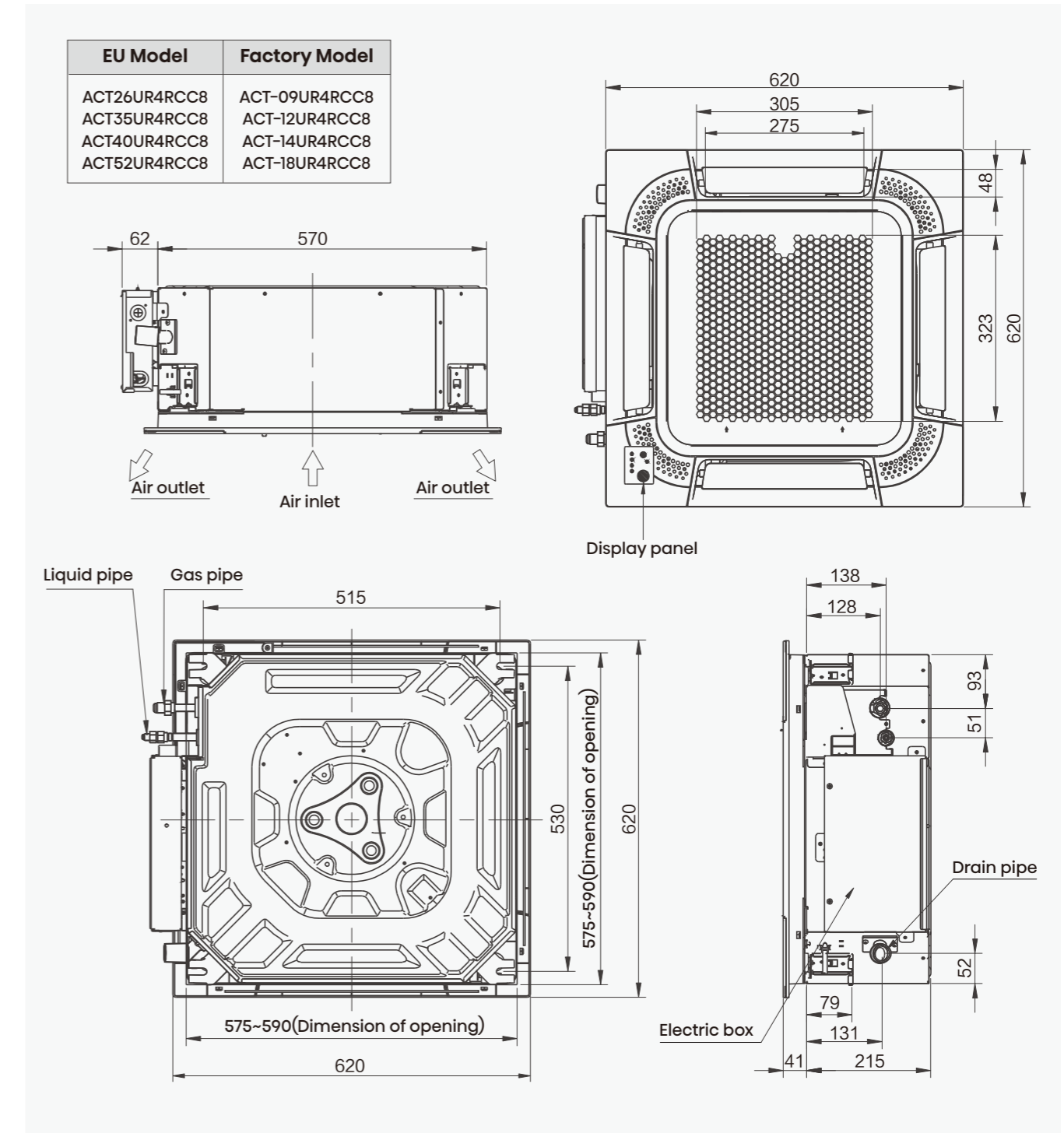

# Round Flow Cassette

## DETAILED TECHNICAL DRAWINGS

EU Model	Factory Model	a
ACT40UR4RJC8 ACT40UR4RJC8 ACT60UR4RJC8 ACT71UR4RJC8	AUC-14UR4RJC8 AUC-14UR4RJC8 ACT-21UR4RJC8 ACT-24UR4RJC8	264
AUC105UR4RKC8 AUC125UR4RKC8 AUC140UR4RKC8	AUC-36UR4RKC8 AUC-42UR4RKC8 AUC-48UR4RKC8	300

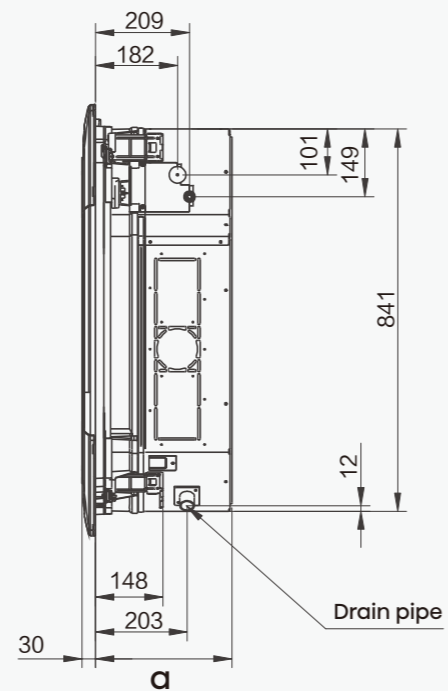
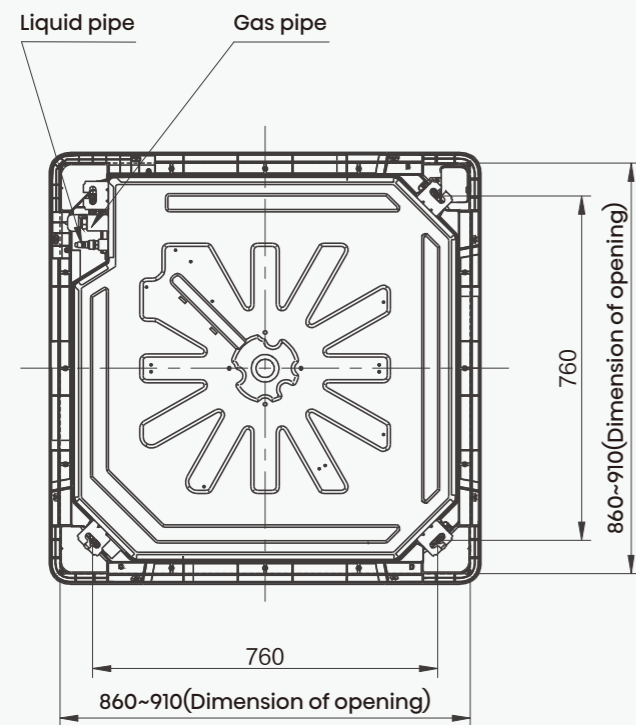
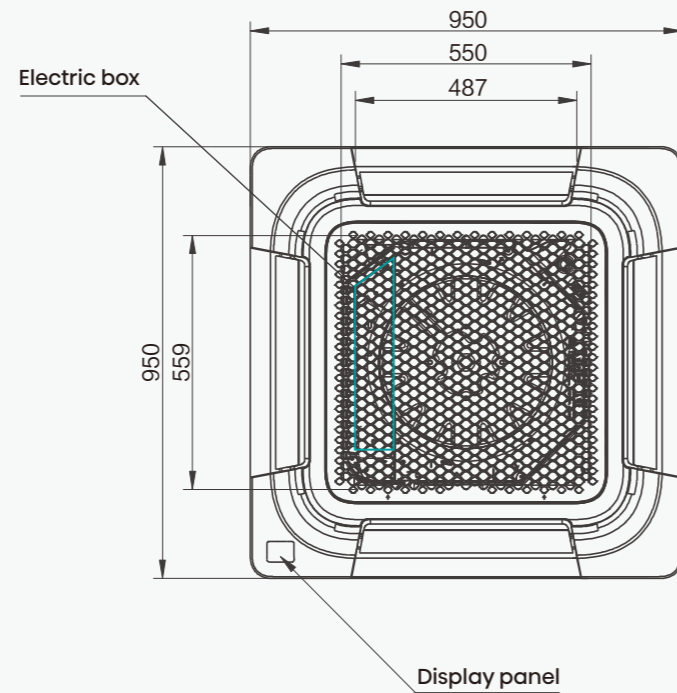
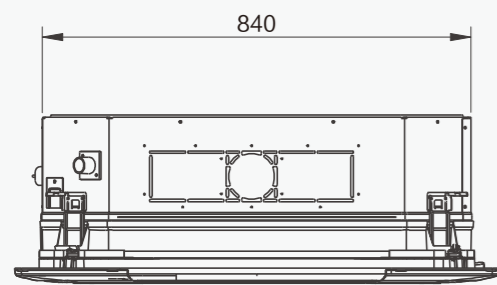

# Slim Duct

## DETAILED TECHNICAL DRAWINGS

EU Model	Factory Model	a	b	c	d
ADT26UX4RBL8 ADT35UX4RBL8	ADT-09UX4RBL8 ADT-12UX4RBL8	961	910	749	786
ADT40UX4RCL8 ADT52UX4RCL8 ADT71UX4RCL8	ADT-14UX4RCL8 ADT-18UX4RCL8 ADT-24UX4RCL8	1231	1180	1019	1056

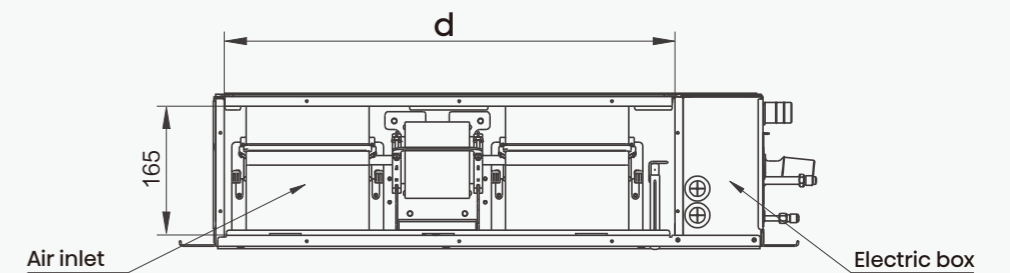
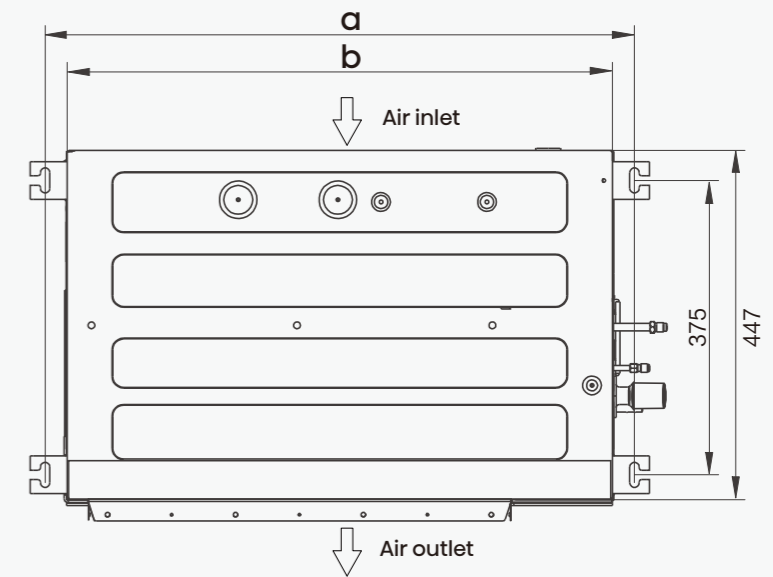
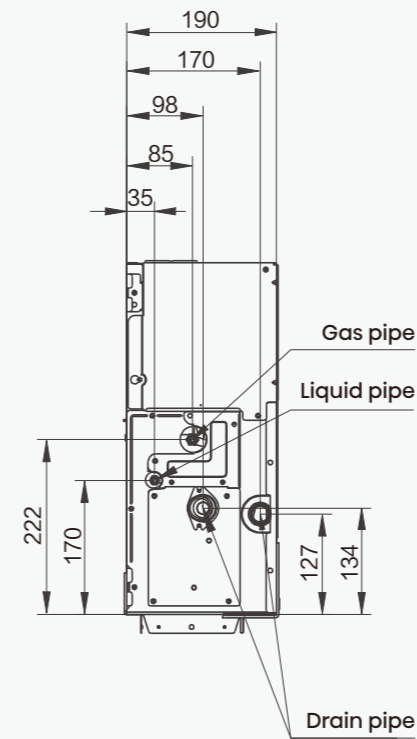
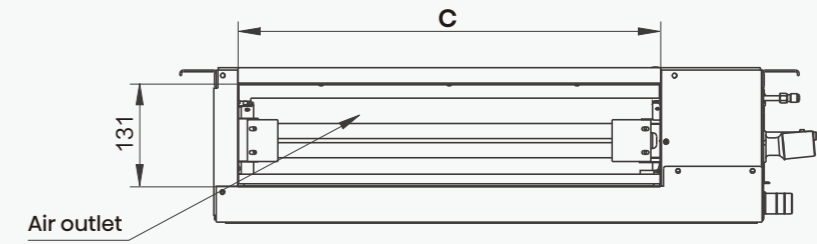

EU Model	Factory Model
ADT40UX4RGM8	ADT-14UX4RGM8
ADT52UX4RGM8	ADT-18UX4RGM8

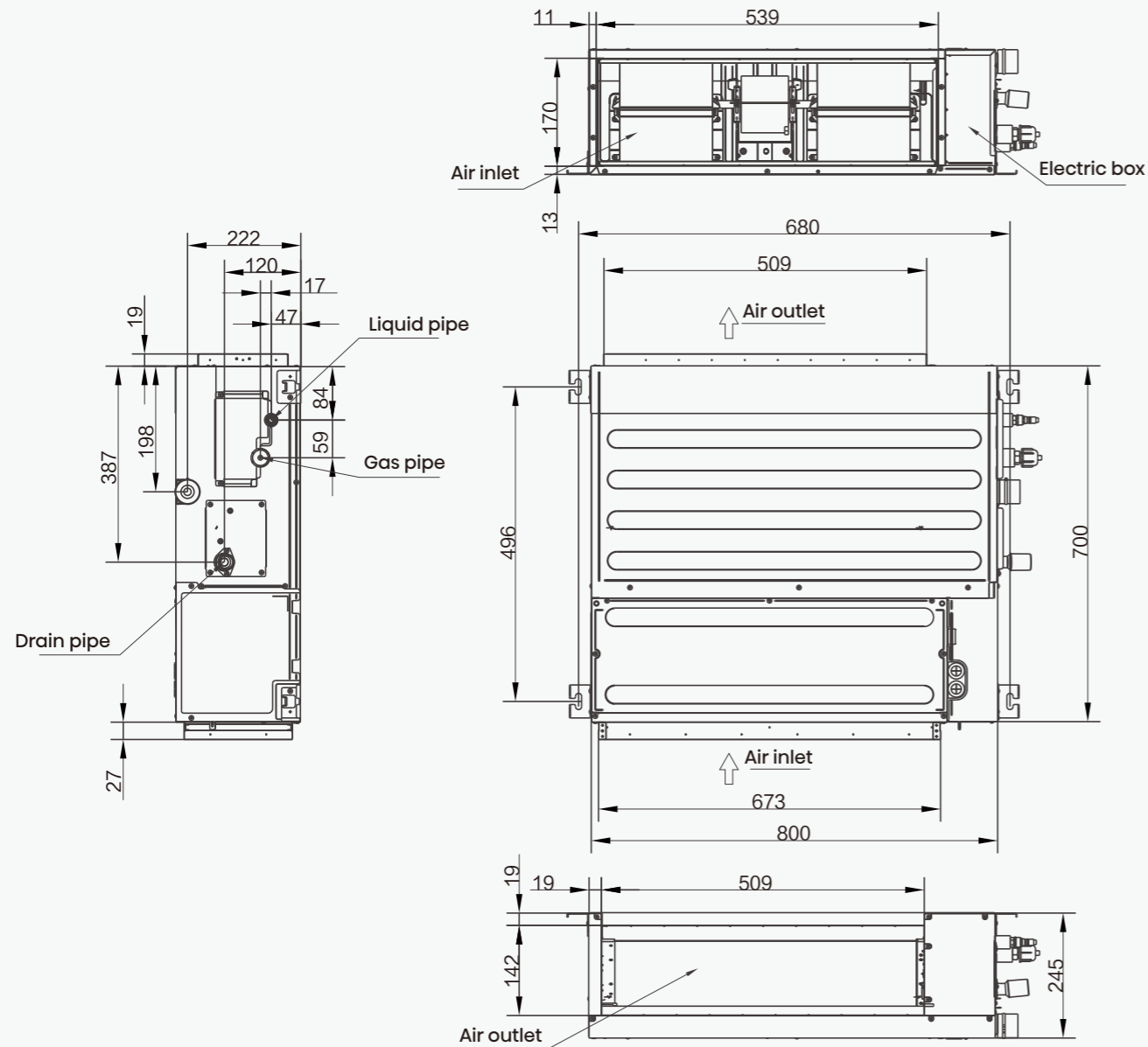

EU Model	Factory Model
ADT60UX4RFM8	ADT-21UX4RFM8
ADT71UX4RFM8	ADT-24UX4RFM8
AUD90UX4RFM8	AUD-30UX4RFM8

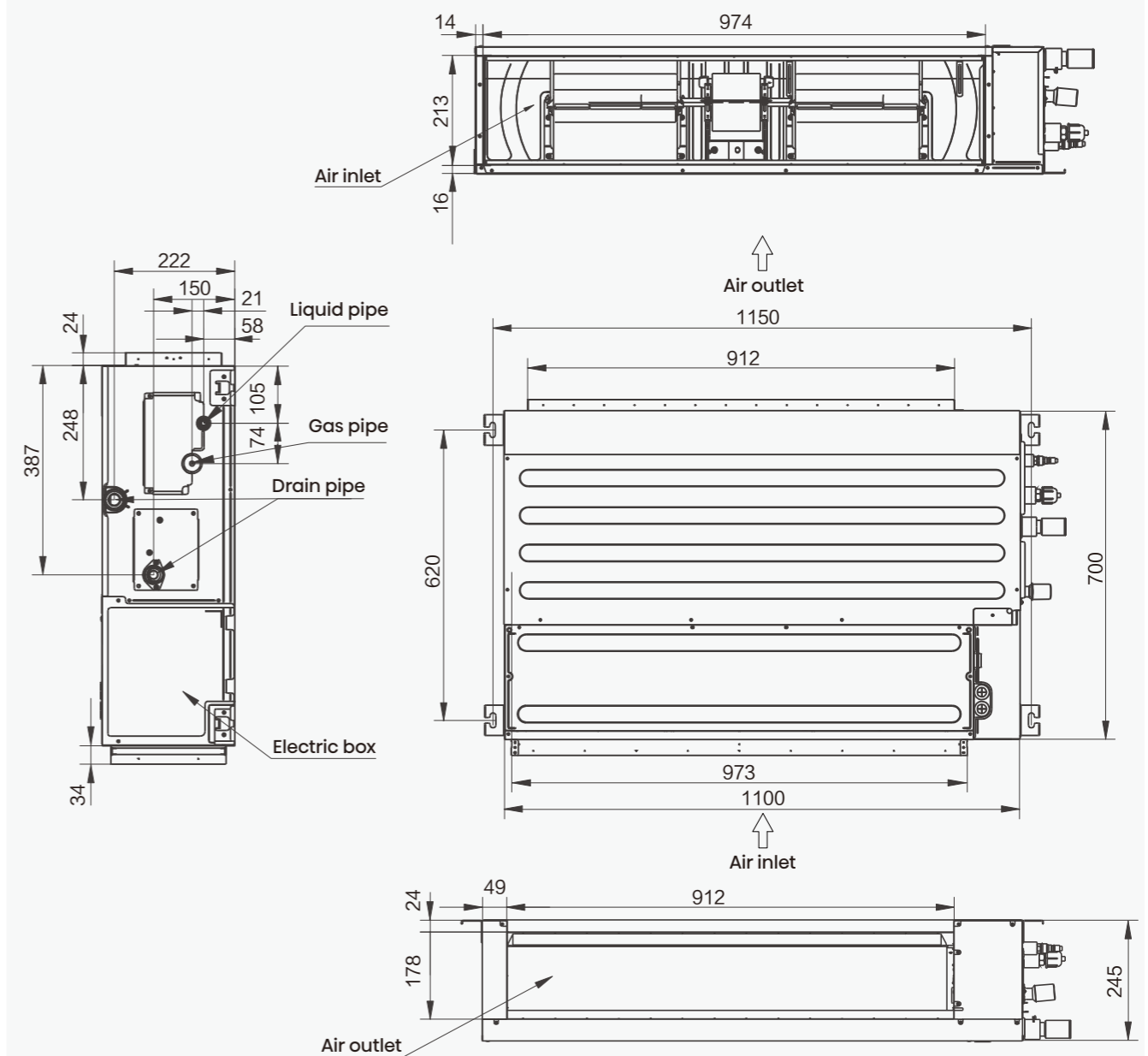

EU Model	Factory Model
AUD105UX4RQM8	AUD-36UX4RQM8
AUD125UX4RQM8	AUD-42UX4RQM8
AUD140UX4RQM8	AUD-48UX4RQM8

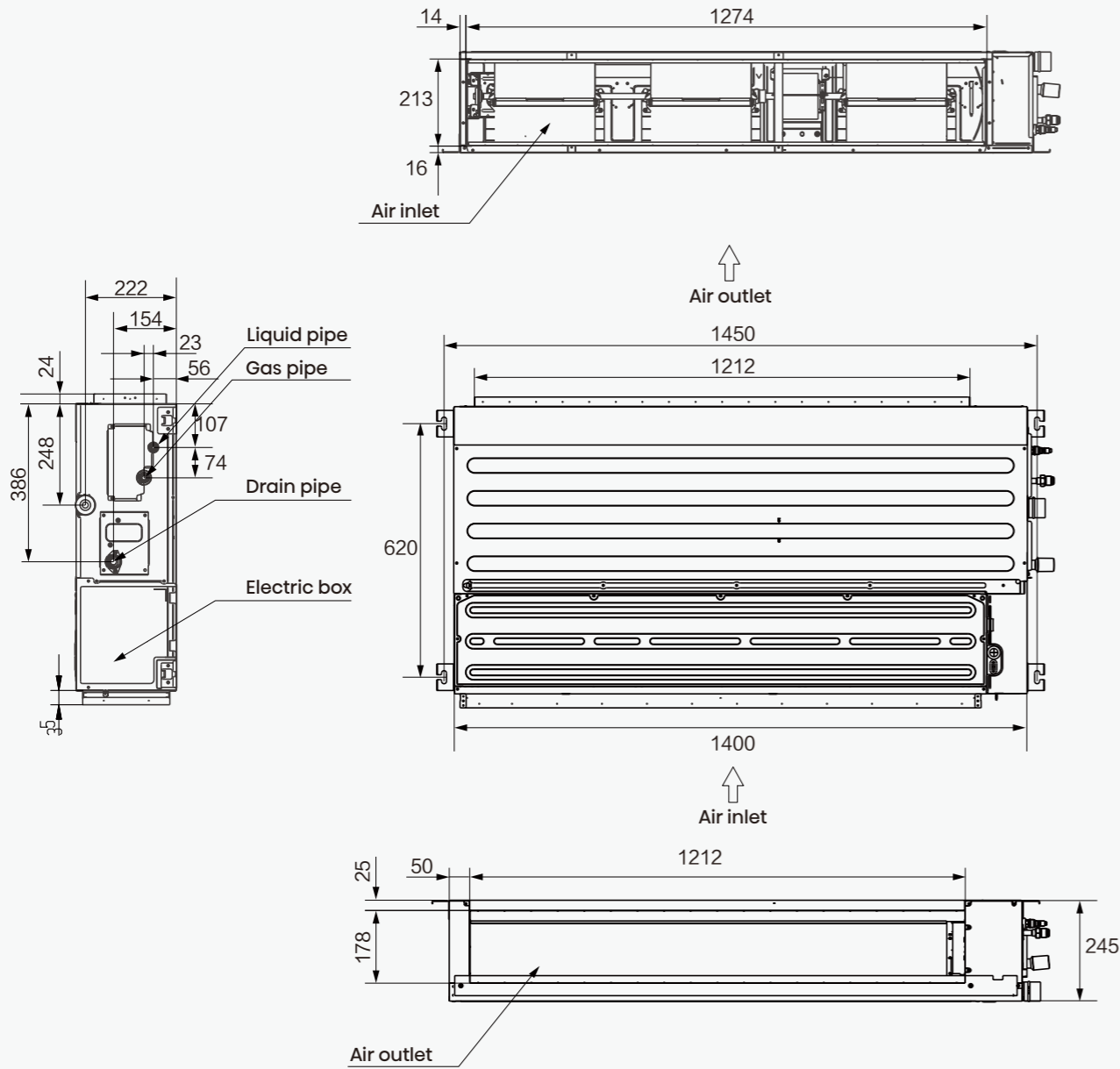

EU Model	Factory Model
AUD105UX4REH8	AUD-36UX4REH8
AUD125UX4REH8	AUD-42UX4REH8
AUD140UX4REH8	AUD-48UX4REH8
AUD175UX4REH8	AUD-60UX4REH8

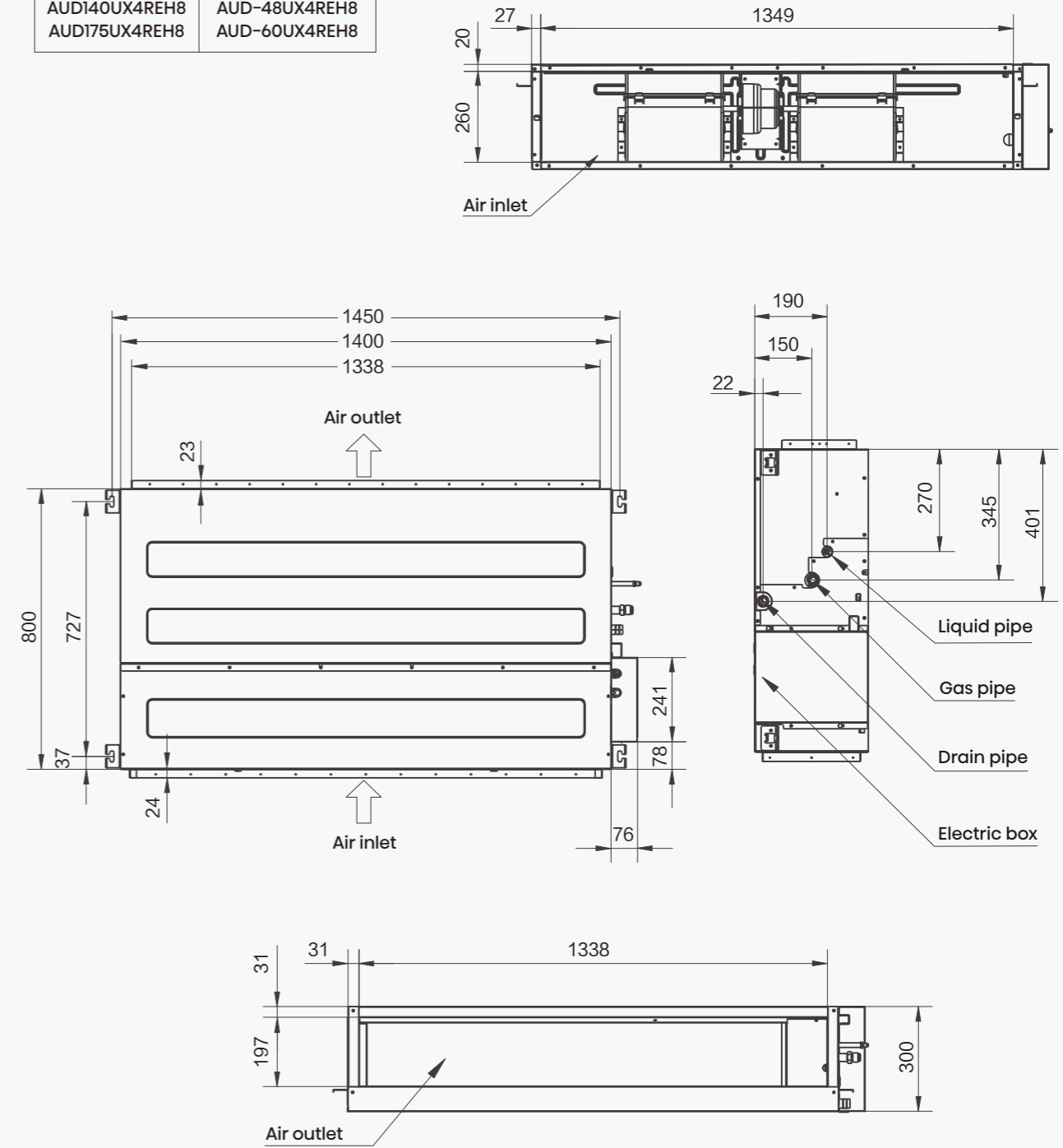

EU Model	Factory Model
AUD200UX4RPH8	AUD-75UX4RPH8
AUD250UX4RPH8	AUD-85UX4RPH8

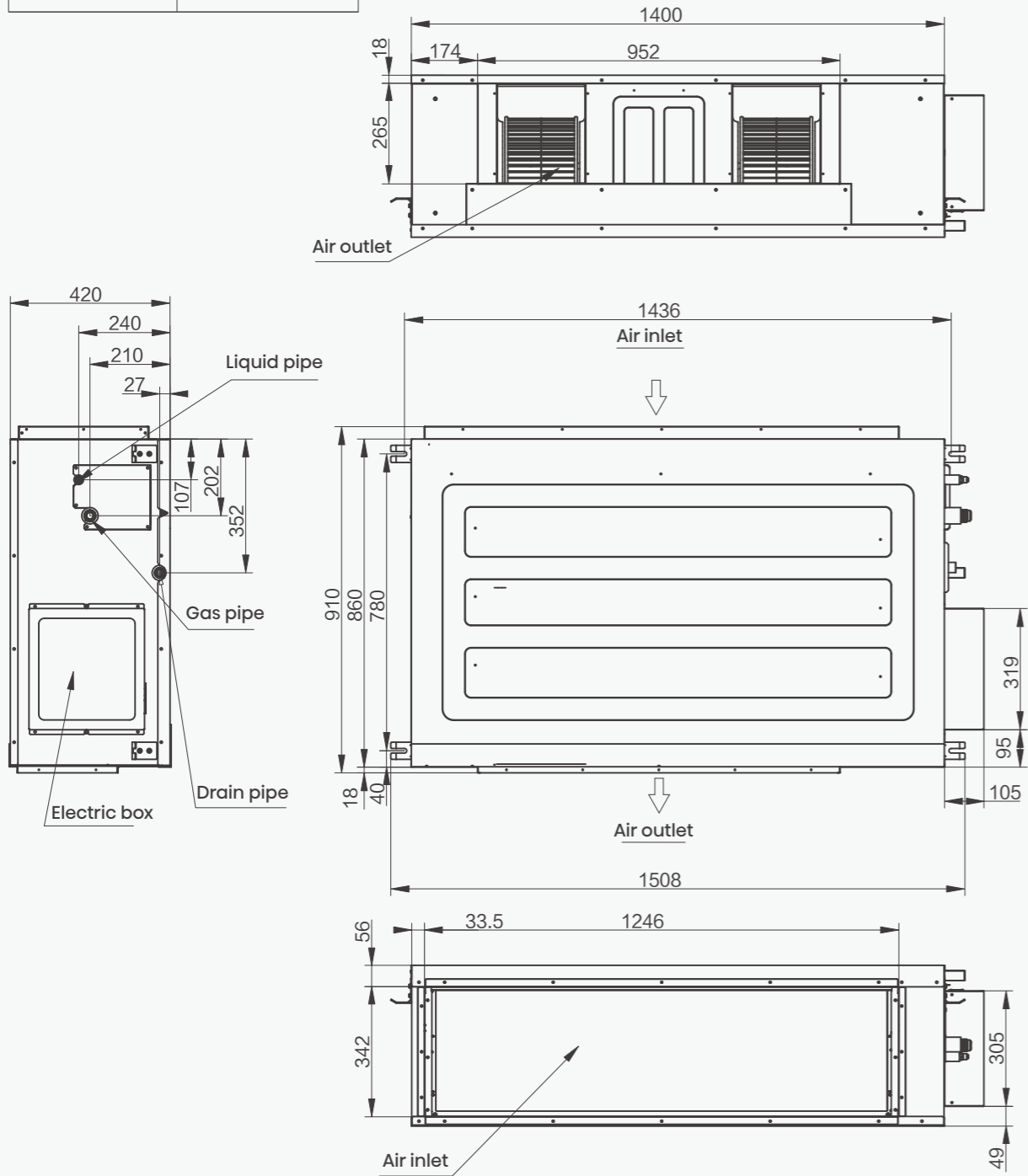

EU Model	Factory Model	a	b	c
AVT60UR4RB8	AVT-21UR4RB8	1285	1150	1207
AVT71UR4RB8	AVT-24UR4RB8			
AUV105UR4RC8	AUV-36UR4RC8			
AUV125UR4RC8	AUV-42UR4RC8	1580	1445	1502
AUV140UR4RC8	AUV-48UR4RC8			
AUV175UR4RC8	AUV-60UR4RC8			

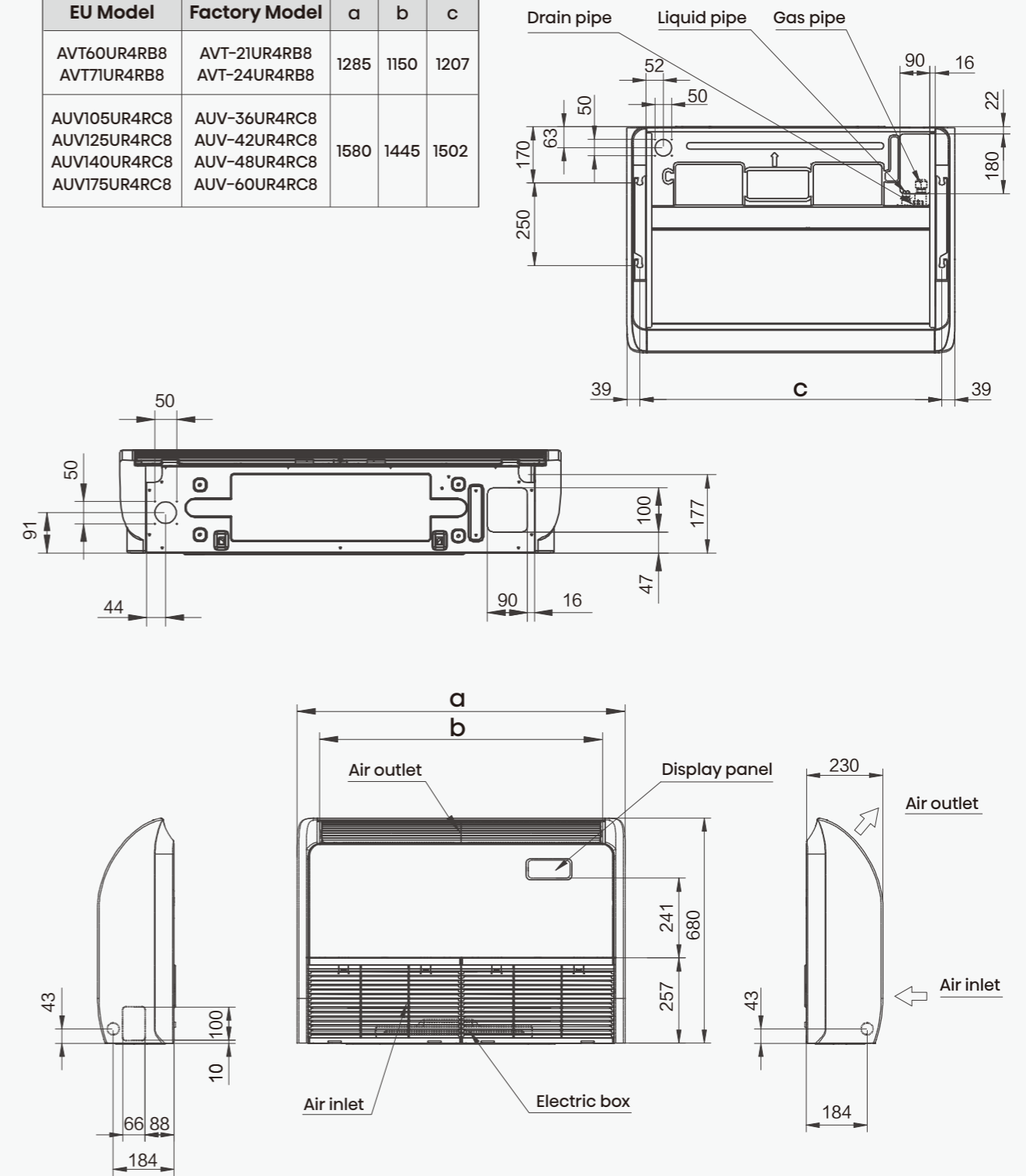

EU Model	Factory Model
AKT26UR4RK8	AKT-09UR4RK8
AKT35UR4RK8	AKT-12UR4RK8
AKT40UR4RK8	AKT-14UR4RK8
AKT52UR4RK8	AKT-18UR4RK8

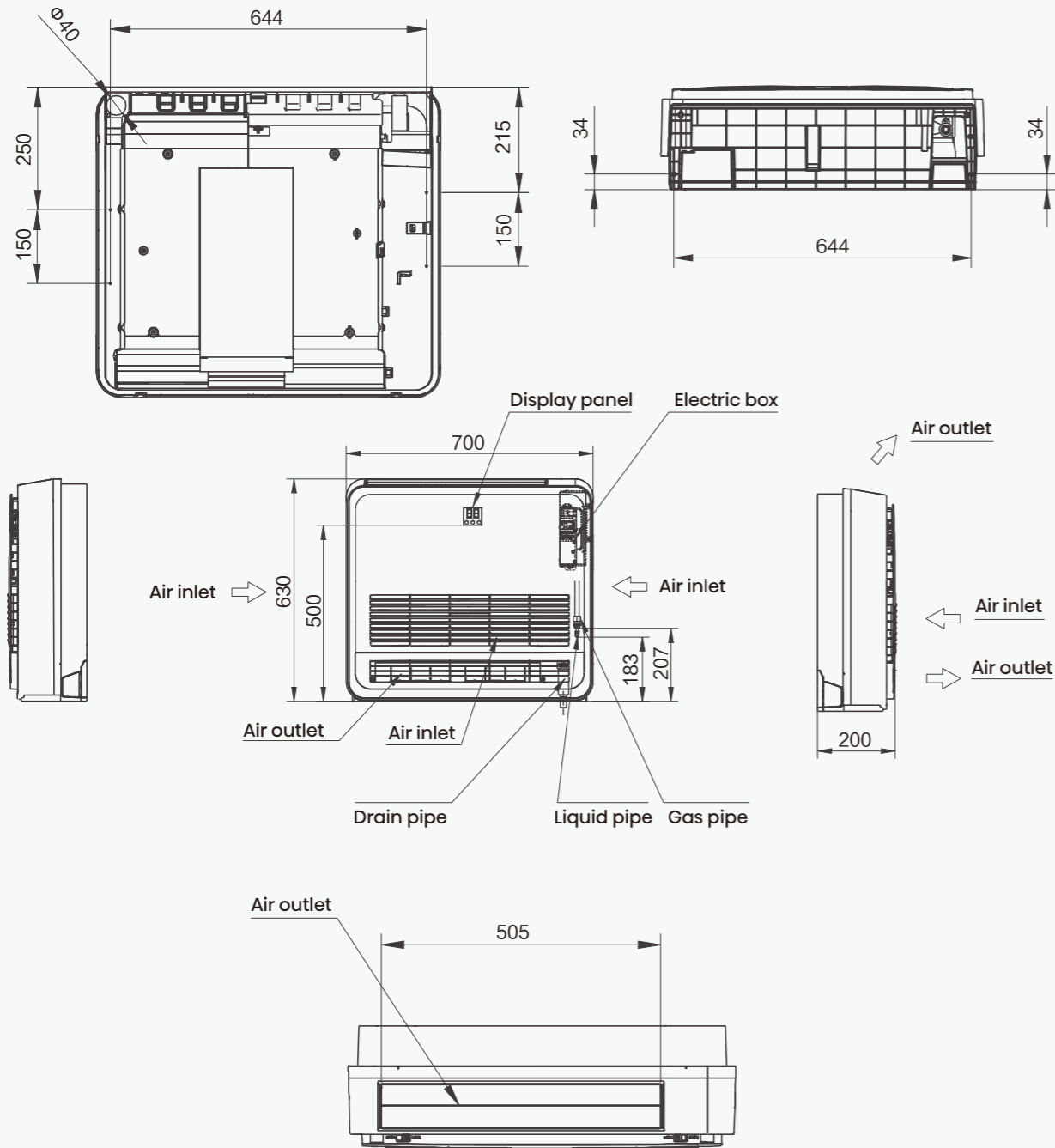

EU Model	Factory Model
AUF71UR4RCPA8	AUF-24UR4RCPA8

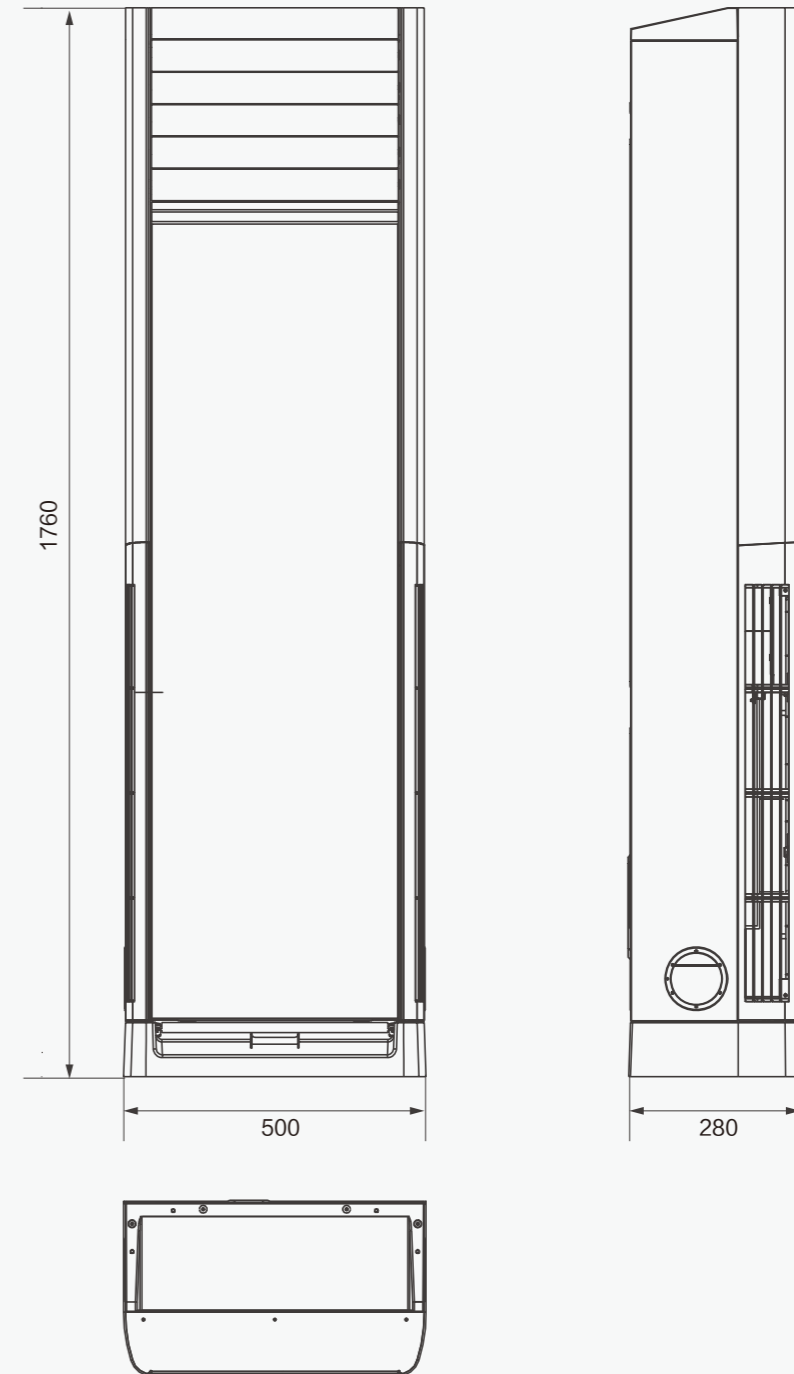

# Floor Standing

## DETAILED TECHNICAL DRAWINGS

EU Model	Factory Model
AUF105UR4RMPA8	AUF-36UR4RMPA8
AUF140UR4RMPA8	AUF-48UR4RMPA8

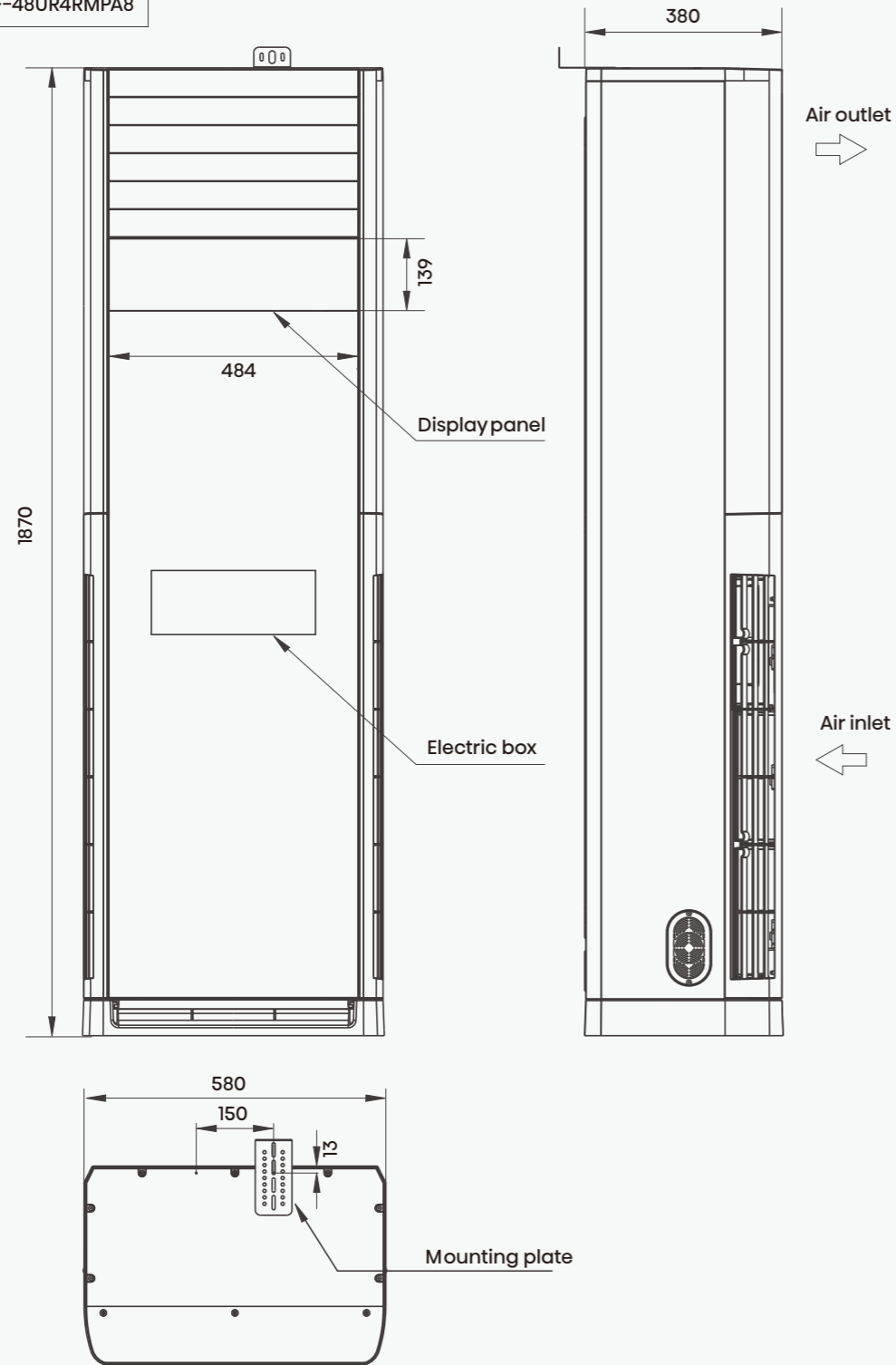

# Floor Standing

## DETAILED TECHNICAL DRAWINGS

EU Model	Factory Model
AUF175UR4RHPA8	AUF-60UR4RHPA8

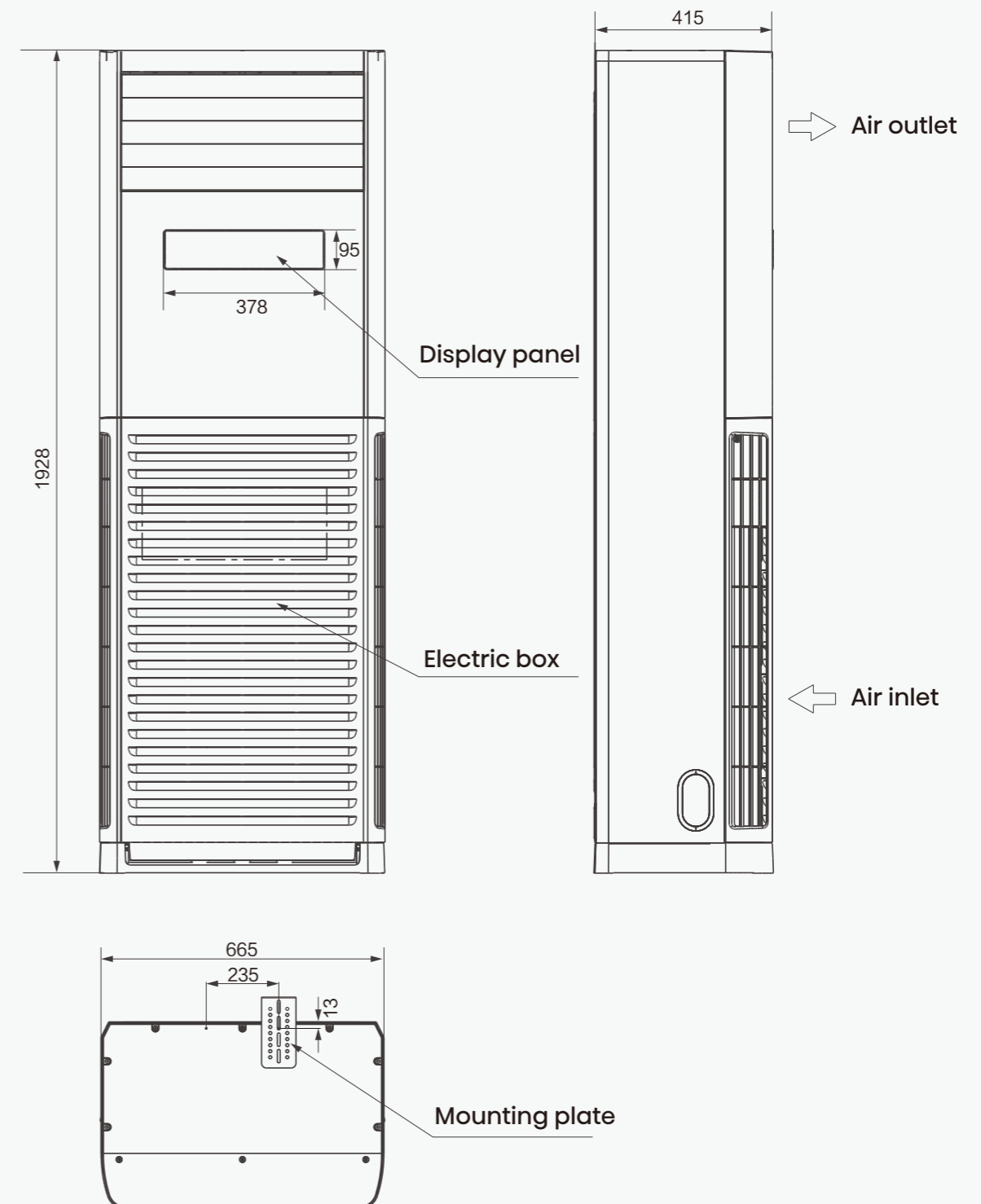

# Outdoor Unit

## DETAILED TECHNICAL DRAWINGS

EU Model	Factory Model
AUW26U4RS8	AUW-09U4RS8
AUW35U4RS8	AUW-12U4RS8
AUW40U4RS7	AUW-14U4RS7
AUW52U4RS7	AUW-18U4RS7

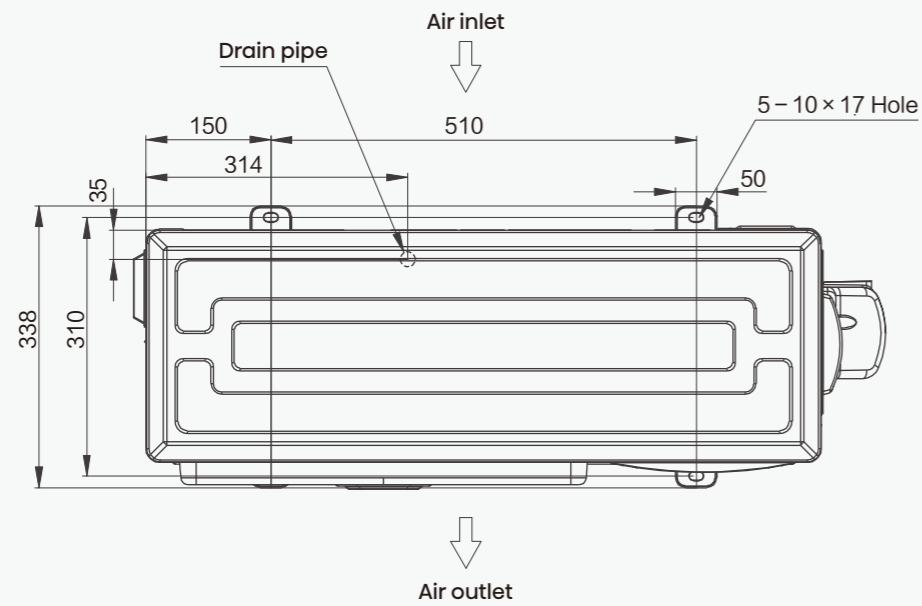
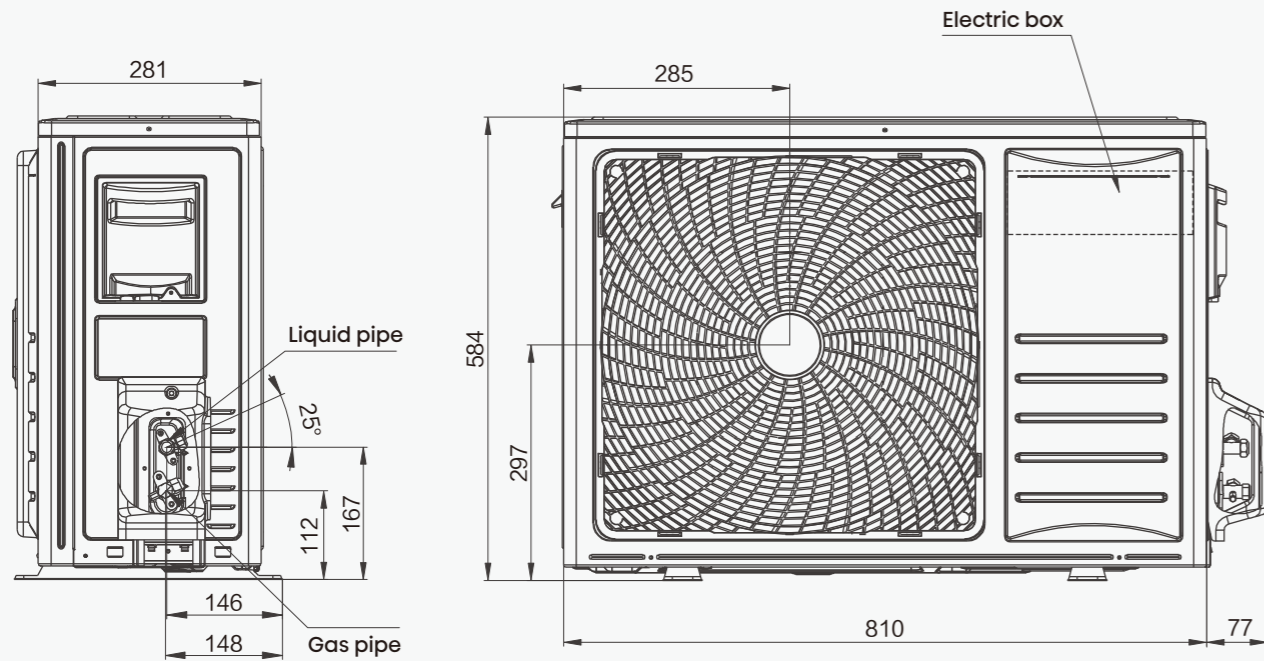

# Outdoor Unit

## DETAILED TECHNICAL DRAWINGS

EU Model	Factory Model
AUW40U4RJ8	AUW-14U4RJ8
AUW52U4RJ8	AUW-18U4RJ8
AUW60U4RJ7	AUW-21U4RJ7
AUW71U4RJ7	AUW-24U4RJ7

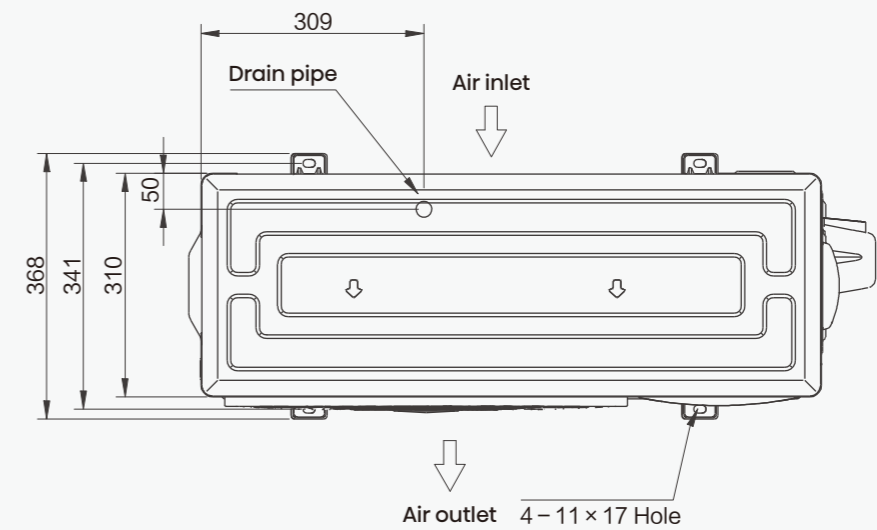
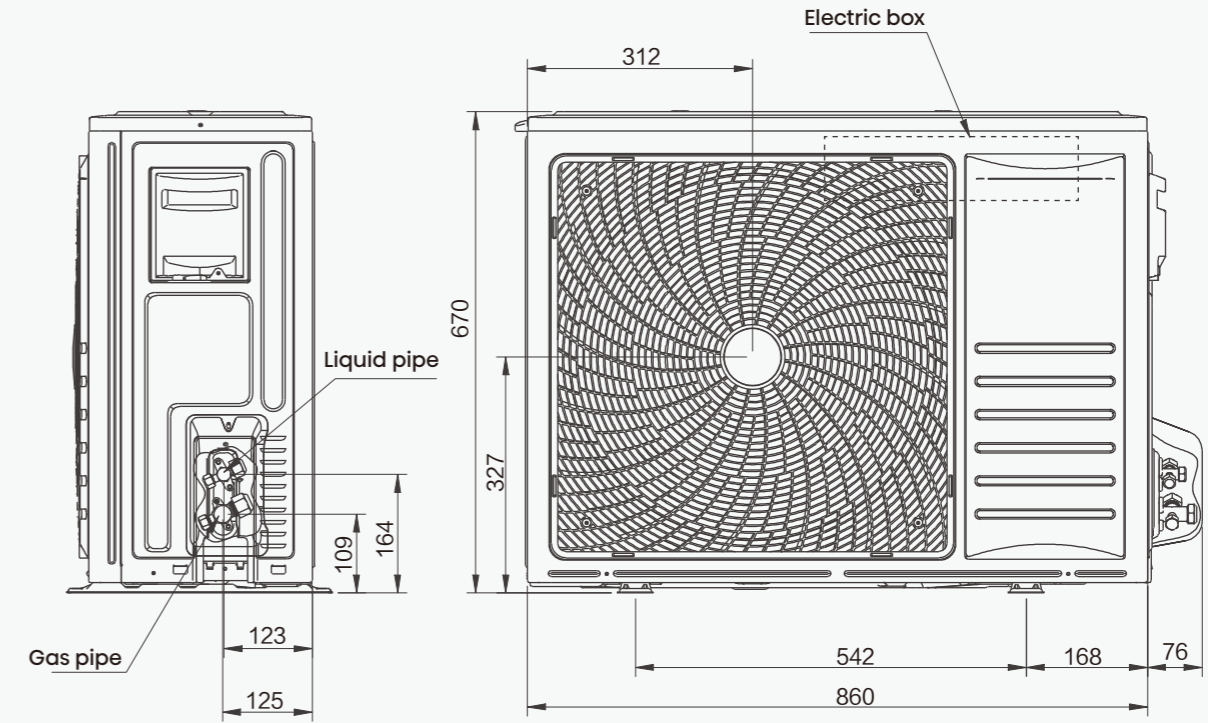

# Outdoor Unit

## DETAILED TECHNICAL DRAWINGS

EU Model	Factory Model
AUW60U4RK8	AUW-21U4RK8
AUW71U4RK8	AUW-24U4RK8
AUW90U4RK8	AUW-30U4RK8
AUW105U4RK7	AUW-36U4RK7

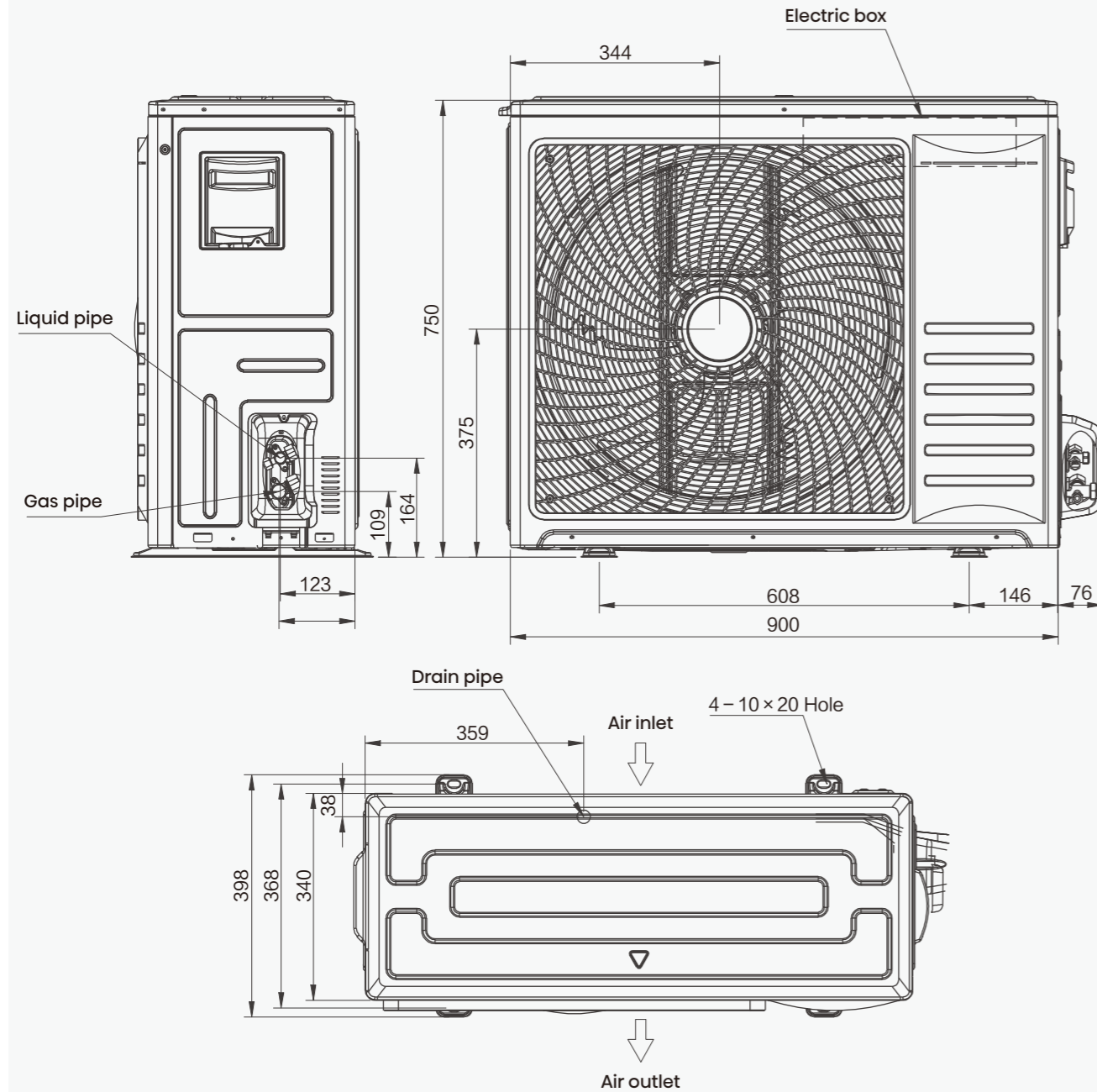

# Outdoor Unit

## DETAILED TECHNICAL DRAWINGS

EU Model	Factory Model
AUW140U6RQ7	AUW-48U6RQ7

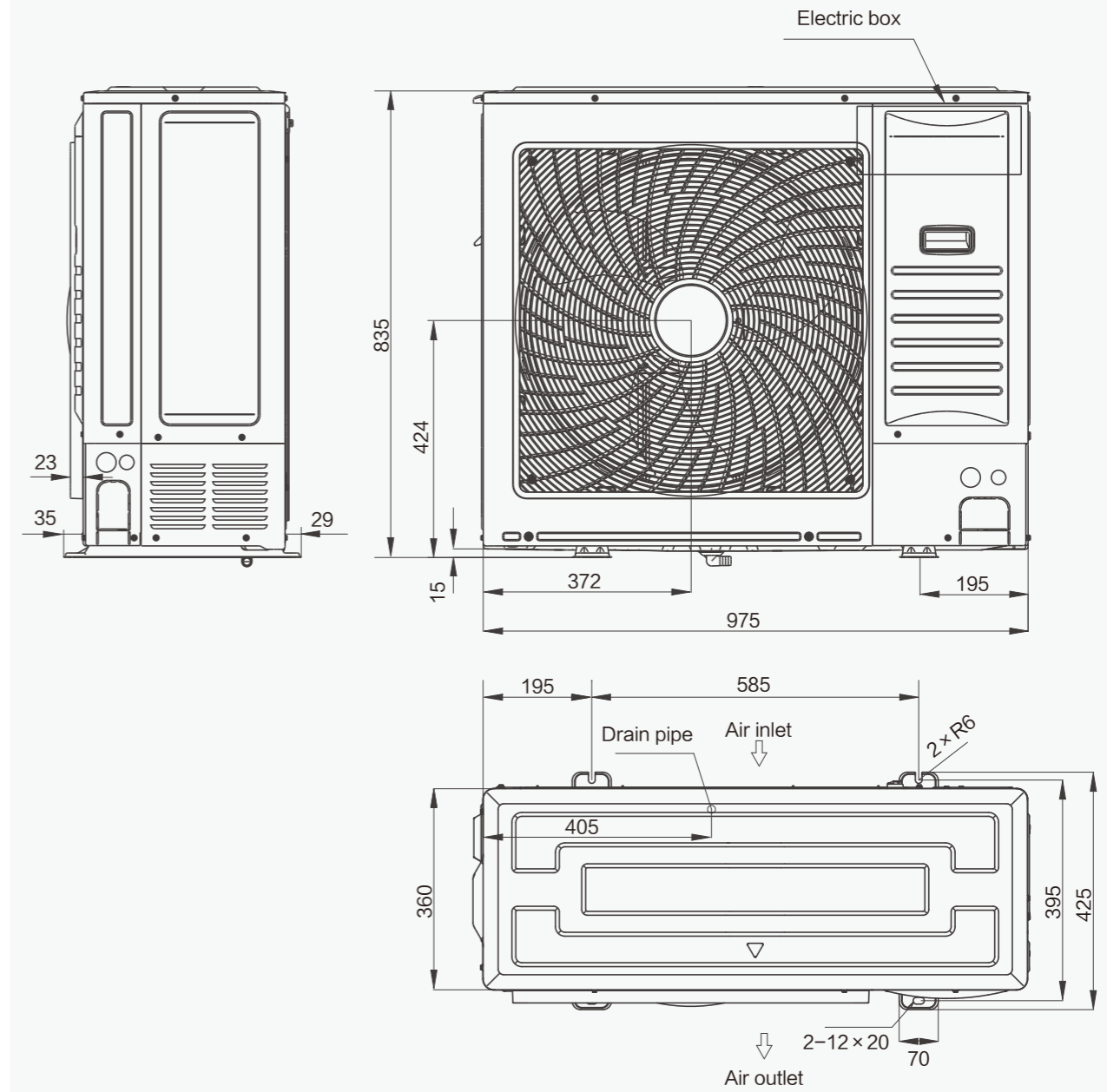

# Outdoor Unit

## DETAILED TECHNICAL DRAWINGS

EU Model	Factory Model
AUW105U4RW8	AUW-36U4RW8
AUW125U4RW8	AUW-42U4RW8
AUW140U4RW8	AUW-48U4RW8
AUW105U6RW8	AUW-36U6RW8
AUW125U6RW8	AUW-42U6RW8
AUW140U6RW8	AUW-48U6RW8
AUW175U6RW8	AUW-60U6RW8

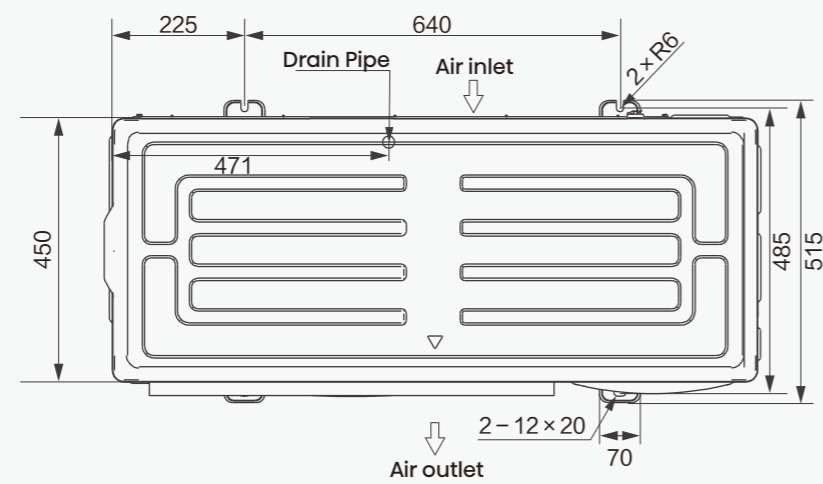
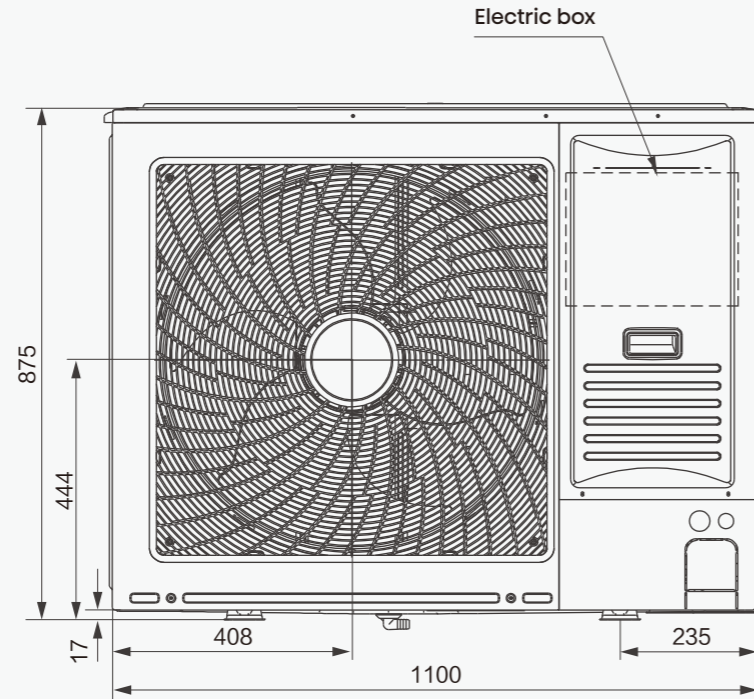
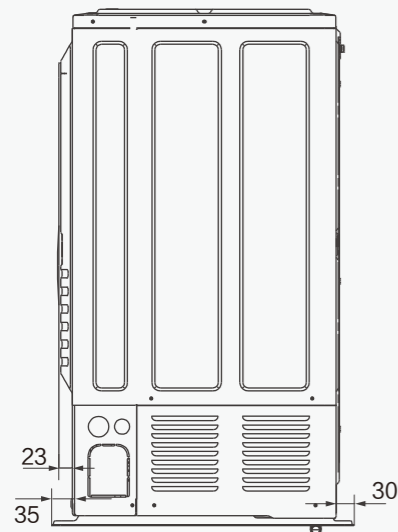

# Outdoor Unit

## DETAILED TECHNICAL DRAWINGS

EU Model	Factory Model
AUW200U6RZ8	AUW-75U6RZ8
AUW-85U6RZ8	AUW-85U6RZ8

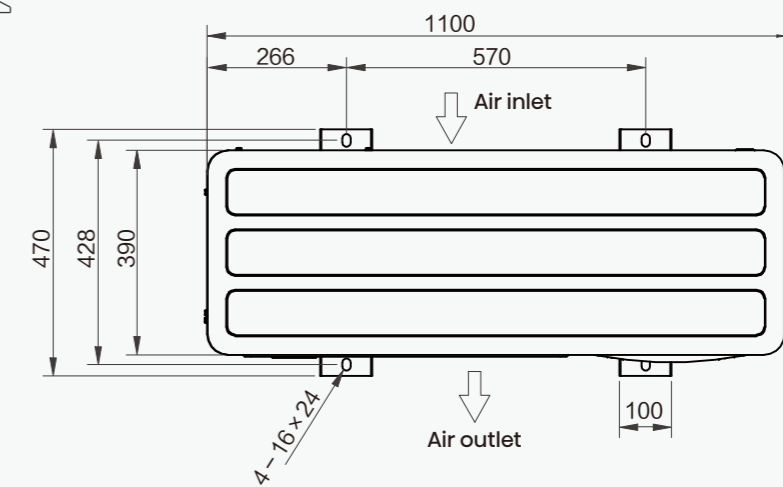
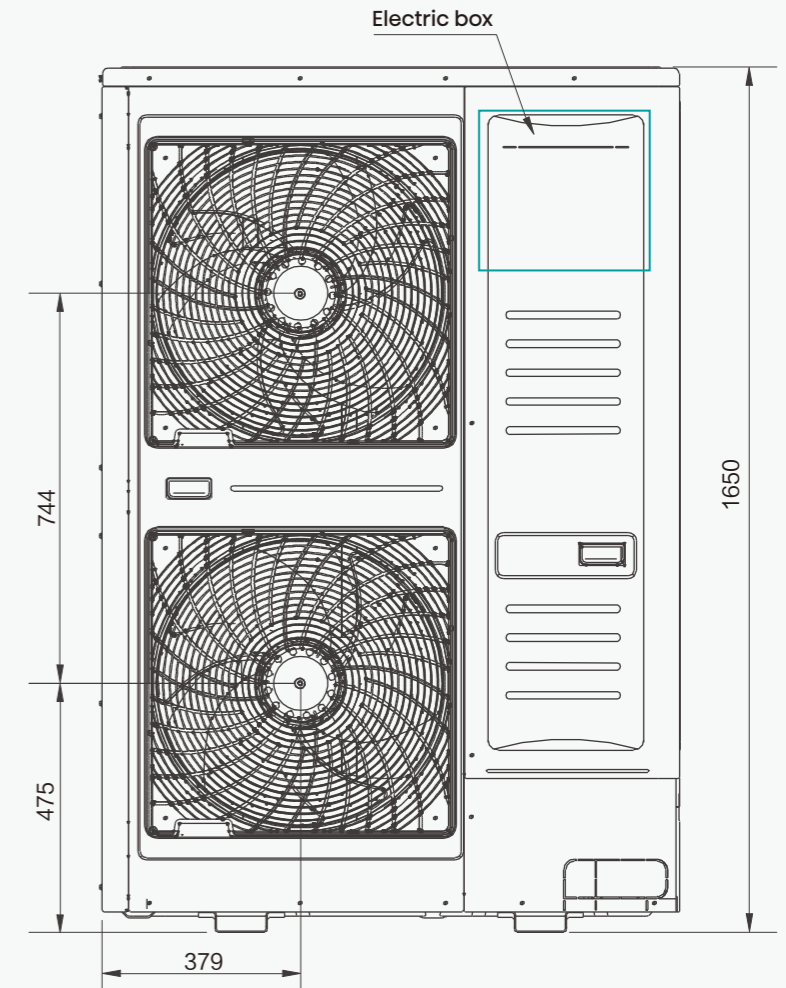
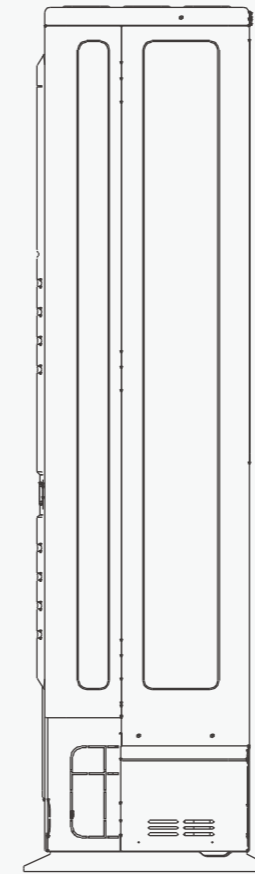

# QUICK SEARCH GUIDE

## Turbo Inverter R32

EU Model (Hisense)		Model		Nominal Capacity				Energy Efficiency/Cooling				Energy Efficiency/Heating Average				Energy Efficiency/Heating Warmer				Sound Power		Pipe Size
Indoor Unit	Outdoor Unit	Indoor Unit	Outdoor Unit	Cooling(W)	EER(W/W)	Heating(W)	COP(W/W)	Pdc(W)	SEER	Energy Level	η <sub>1</sub> s,c	Pdh(W)	SCOP	Level	η <sub>1</sub> s,h	Pdh (W)	SCOP	Level	η <sub>1</sub> s,h	IDU(dB)	ODU(dB)	Gas/Liquid(mm)
ACT26UR4RCC8	AUW26U4RS8	ACT-09UR4RCC8	AUW-09U4RS8	2600	4.19	3200	4.27	2600	7.20	A++	340%	3000	4.60	A++	216%	3000	5.35	A+++	252%	54	62	Φ 6.35/Φ 9.52(1/4/3/8)
ACT35UR4RCC8	AUW35U4RS8	ACT-12UR4RCC8	AUW-12U4RS8	3500	4.00	4000	4.00	3500	7.00	A++	330%	3000	4.60	A++	216%	3000	5.35	A+++	252%	54	62	Φ 6.35/Φ 9.52(1/4/3/8)
ACT40UR4RCC8	AUW40U4RJ8	ACT-14UR4RCC8	AUW-14U4RJ8	4100	4.00	4600	4.00	4100	6.70	A++	316%	4000	4.40	A+	207%	4000	5.35	A+++	252%	57	64	Φ 6.35/Φ 12.7(1/4/1/2)
ACT52UR4RCC8	AUW52U4RJ8	ACT-18UR4RCC8	AUW-18U4RJ8	5000	3.67	5500	3.71	5000	6.70	A++	316%	4000	4.40	A+	207%	4000	5.35	A+++	252%	57	64	Φ 6.35/Φ 12.7(1/4/1/2)
ACT40UR4RJC8	AUW40U4RJ8	AUC-14UR4RJC8	AUW-14U4RJ8	4100	4.40	4600	4.50	4100	7.30	A++	345%	4000	4.60	A++	216%	4000	5.35	A+++	252%	52	64	Φ 6.35/Φ 12.7(1/4/1/2)
ACT52UR4RJC8	AUW52U4RJ8	AUC-18UR4RJC8	AUW-18U4RJ8	5000	4.00	5500	4.30	5000	7.20	A++	340%	4000	4.60	A++	216%	4000	5.35	A+++	252%	52	64	Φ 6.35/Φ 12.7(1/4/1/2)
ACT60UR4RJC8	AUW60U4RK8	ACT-21UR4RJC8	AUW-21U4RK8	6200	3.90	7300	4.00	6200	7.50	A++	354%	5500	4.60	A++	216%	5500	5.35	A+++	252%	54	68	Φ 9.52/Φ 15.88(3/8/5/8)
ACT71UR4RJC8	AUW71U4RK8	ACT-24UR4RJC8	AUW-24U4RK8	7000	3.70	8000	3.80	7000	7.10	A++	335%	5500	4.60	A++	216%	5500	5.35	A+++	252%	54	68	Φ 9.52/Φ 15.88(3/8/5/8)
AUC105UR4RKC8	AUW105U4RW8	AUC-36UR4RKC8	AUW-36U4RW8	10000	3.85	11000	3.90	10000	7.50	A++	354%	8000	4.60	A++	216%	8000	5.40	A+++	254%	62	69	Φ 9.52/Φ 15.88(3/8/5/8)
AUC105UR4RKC8	AUW105U6RW8	AUC-36UR4RKC8	AUW-36U6RW8	10000	3.85	11000	3.90	10000	7.50	A++	354%	8000	4.60	A++	216%	8000	5.40	A+++	254%	62	69	Φ 9.52/Φ 15.88(3/8/5/8)
AUC125UR4RKC8	AUW125U4RW8	AUC-42UR4RKC8	AUW-42U4RW8	12100	3.61	13500	3.75	12100	7.00	-	277%	9000	4.50	-	177%	9000	5.40	-	213%	64	73	Φ 9.52/Φ 15.88(3/8/5/8)
AUC125UR4RKC8	AUW125U6RW8	AUC-42UR4RKC8	AUW-42U6RW8	12100	3.61	13500	3.75	12100	7.00	-	277%	9000	4.50	-	177%	9000	5.40	-	213%	64	73	Φ 9.52/Φ 15.88(3/8/5/8)
AUC140UR4RKC8	AUW140U4RW8	AUC-48UR4RKC8	AUW-48U4RW8	13500	3.21	16000	3.41	13500	6.70	-	265%	9000	4.50	-	177%	9000	5.40	-	213%	64	74	Φ 9.52/Φ 15.88(3/8/5/8)
AUC140UR4RKC8	AUW140U6RW8	AUC-48UR4RKC8	AUW-48U6RW8	13500	3.21	16000	3.41	13500	6.70	-	265%	9000	4.50	-	177%	9000	5.40	-	213%	64	74	Φ 9.52/Φ 15.88(3/8/5/8)
AUC175UR4RKC8	AUW175U6RW8	AUC-60UR4RKC8	AUW-60U6RW8	16000	2.91	17500	2.97	16000	6.10	-	241%	10000	4.00	-	157%	1000	4.90	-	193%	66	75	Φ 9.52/Φ 15.88(3/8/5/8)
ADT26UX4RBL8	AUW26U4RS8	ADT-09UX4RBL8	AUW-09U4RS8	2600	4.41	3200	4.31	2600	7.20	A++	340%	3000	4.30	A+	202%	3000	5.35	A+++	252%	50	62	Φ 6.35/Φ 9.52(1/4/3/8)
ADT35UX4RBL8	AUW35U4RS8	ADT-12UX4RBL8	AUW-12U4RS8	3500	4.02	4000	4.00	3500	7.00	A++	330%	3000	4.30	A+	202%	3000	5.35	A+++	252%	50	62	Φ 6.35/Φ 9.52(1/4/3/8)
ADT40UX4RCL8	AUW40U4RJ8	ADT-14UX4RCL8	AUW-14U4RJ8	4100	4.15	4600	4.30	4100	7.00	A++	330%	4000	4.60	A++	216%	4000	5.35	A+++	252%	57	64	Φ 6.35/Φ 12.7(1/4/1/2)
ADT52UX4RCL8	AUW52U4RJ8	ADT-18UX4RCL8	AUW-18U4RJ8	5000	3.90	5500	4.15	5000	7.00	A++	330%	4000	4.60	A++	216%	4000	5.35	A+++	252%	57	64	Φ 6.35/Φ 12.7(1/4/1/2)
ADT40UX4RGM8	AUW40U4RJ8	ADT-14UX4RGM8	AUW-14U4RJ8	4100	4.18	4600	4.69	4100	7.20	A++	340%	4000	4.60	A++	216%	4000	5.50	A+++	259%	54	64	Φ 6.35/Φ 12.7(1/4/1/2)
ADT52UX4RGM8	AUW52U4RJ8	ADT-18UX4RGM8	AUW-18U4RJ8	5000	4	5500	4.51	5000	7.00	A++	330%	4000	4.60	A++	216%	4000	5.50	A+++	259%	54	64	Φ 6.35/Φ 12.7(1/4/1/2)
ADT60UX4RFM8	AUW60U4RK8	ADT-21UX4RFM8	AUW-21U4RK8	6200	4.17	7300	4.17	6200	7.50	A++	354%	5500	4.60	A++	216%	5500	5.40	A+++	254%	54	68	Φ 9.52/Φ 15.88(3/8/5/8)
ADT71UX4RFM8	AUW71U4RK8	ADT-24UX4RFM8	AUW-24U4RK8	7000	4.06	8000	4.06	7000	7.30	A++	345%	5500	4.60	A++	216%	5500	5.40	A+++	254%	54	68	Φ 9.52/Φ 15.88(3/8/5/8)
AUD90UX4RFM8	AUW90U4RK8	AUD-30UX4RFM8	AUW-30U4RK8	8800	3.73	9500	3.73	8800	6.80	A++	321%	5500	4.40	A+	207%	5500	5.40	A+++	254%	56	68	Φ 9.52/Φ 15.88(3/8/5/8)
AUD105UX4RQM8	AUW105U4RW8	AUD-36UX4RQM8	AUW-36U4RW8	10000	3.80	11000	4.10	10000	7.10	A++	335%	8000	4.40	A+	207%	8000	5.40	A+++	254%	59	69	Φ 9.52/Φ 15.88(3/8/5/8)
AUD105UX4RQM8	AUW105U6RW8	AUD-36UX4RQM8	AUW-36U6RW8	10000	3.80	11000	4.10	10000	7.10	A++	335%	8000	4.40	A+	207%	8000	5.40	A+++	254%	59	69	Φ 9.52/Φ 15.88(3/8/5/8)
AUD125UX4RQM8	AUW125U4RW8	AUD-42UX4REM8	AUW-42U4RW8	12100	3.81	13500	4.01	12100	7.10	-	281%	9000	4.50	-	177%	9000	5.40	-	213%	63	74	Φ 9.52/Φ 15.88(3/8/5/8)
AUD125UX4RQM8	AUW125U6RW8	AUD-42UX4RQM8	AUW-42U6RW8	12100	3.81	13500	4.01	12100	7.10	-	281%	9000	4.50	-	177%	9000	5.40	-	213%	63	74	Φ 9.52/Φ 15.88(3/8/5/8)
AUD140UX4RQM8	AUW140U4RW8	AUD-48UX4RQM8	AUW-48U4RW8	13500	3.51	16000	3.72	13500	6.85	-	271%	9000	4.50	-	177%	9000	5.40	-	213%	64	74	Φ 9.52/Φ 15.88(3/8/5/8)
AUD140UX4RQM8	AUW140U6RW8	AUD-48UX4RQM8	AUW-48U6RW8	13500	3.51	16000	3.72	13500	6.85	-	271%	9000	4.50	-	177%	9000	5.40	-	213%	64	74	Φ 9.52/Φ 15.88(3/8/5/8)
AUD105UX4REH8	AUW105U4RW8	AUD-36UX4REH8	AUW-36U4RW8	10000	3.80	11000	4.00	10000	7.10	A++	335%	8000	4.40	A+	207%	8000	5.40	A+++	254%	59	69	Φ 9.52/Φ 15.88(3/8/5/8)
AUD105UX4REH8	AUW105U6RW8	AUD-36UX4REH8	AUW-36U6RW8	10000	3.80	11000	4.00	10000	7.10	A++	335%	8000	4.40	A+	207%	8000	5.40	A+++	254%	59	69	Φ 9.52/Φ 15.88(3/8/5/8)
AUD125UX4REH8	AUW125U4RW8	AUD-42UX4REH8	AUW-42U4RW8	12100	3.90	13500	4.00	12100	7.20	-	285%	9000	4.50	-	177%	9000	5.40	-	213%	63	73	Φ 9.52/Φ 15.88(3/8/5/8)
AUD125UX4REH8	AUW125U6RW8	AUD-42UX4REH8	AUW-42U6RW8	12100	3.90	13500	4.00	12100	7.20	-	285%	9000	4.50	-	177%	9000	5.40	-	213%	63	73	Φ 9.52/Φ 15.88(3/8/5/8)
AUD140UX4REH8	AUW140U4RW8	AUD-48UX4REH8	AUW-48U4RW8	13500	3.51	16000	3.81	13500	7.00	-	277%	9000	4.50	-	177%	9000	5.40	-	213%	64	74	Φ 9.52/Φ 15.88(3/8/5/8)
AUD140UX4REH8	AUW140U6RW8	AUD-48UX4REH8	AUW-48U6RW8	13500	3.51	16000	3.81	13500	7.00	-	277%	9000	4.50	-	177%	9000	5.40	-	213%	64	74	Φ 9.52/Φ 15.88(3/8/5/8)
AUD175UX4REH8	AUW175U6RW8	AUD-60UX4REH8	AUW-60U6RW8	16000	3.00	17000	3.71	16000	6.10	-	241%	10000	4.00	-	157%	10000	5.20	-	205%	65	75	Φ 9.52/Φ 15.88(3/8/5/8)
AUD200UX4RPH8	AUW200U6RZ8	AUD-75UX4RPH8	AUW-75U6RZ8	19000	3.00	22000	3.75	19000	6.00	-	237%	17000	3.90	-	153%	17000	4.90	-	193%	81	76	Φ 9.52/Φ 22.22(3/8/7/8)
AUD250UX4RPH8	AUW250U6RZ8	AUD-85UX4RPH8	AUW-85U6RZ8	23000	2.35	25000	3.45	23000	5.82	-	230%	17000	3.90	-	153%	17000	4.90	-	193%	81	76	Φ 9.52/Φ 22.22(3/8/7/8)

# QUICK SEARCH GUIDE

Turbo  
Inverter R32

EU Model (Hisense)		Model		Nominal Capacity				Energy Efficiency/Cooling				Energy Efficiency/Heating Average				Energy Efficiency/Heating Warmer				Sound Power		Pipe Size
Indoor Unit	Outdoor Unit	Indoor Unit	Outdoor Unit	Cooling(W)	EER(W/W)	Heating(W)	COP(W/W)	Pdc(W)	SEER	Energy Level	$\eta$ s,c	Pdh(W)	SCOP	Level	$\eta$ s,h	Pdh (W)	SCOP	Level	$\eta$ s,h	IDU(dB)	ODU(dB)	Gas/Liquid(mm)
AKT26UR4RK8	AKT26UR4RK8	AKT-09UR4RK8	AUW-09U4RS8	2600	4.13	3200	4.00	2600	7.10	A++	335%	3000	4.35	A+	3000	3000	5.35	A+++	252%	54	62	Φ 6.35/Φ 9.52(1/4/3/8)
AKT35UR4RK8	AKT35UR4RK8	AKT-12UR4RK8	AUW-12U4RS8	3500	3.68	4000	3.78	3500	7.00	A++	330%	3000	4.35	A+	3000	3000	5.35	A+++	252%	54	62	Φ 6.35/Φ 9.52(1/4/3/8)
AKT40UR4RK8	AKT40UR4RK8	AKT-14UR4RK8	AUW-14U4RJ8	4100	4.00	4500	3.71	4100	7.00	A++	330%	3500	4.40	A+	3500	4000	5.35	A+++	252%	57	64	Φ 6.35/Φ 12.7(1/4/1/2)
AKT52UR4RK8	AKT52UR4RK8	AKT-18UR4RK8	AUW-18U4RJ8	4900	3.75	5000	3.50	4900	7.00	A++	330%	3500	4.40	A+	3500	4000	5.35	A+++	252%	57	64	Φ 6.35/Φ 12.7(1/4/1/2)
AUV105UR4RC8	AUW105U4RW8	AUV-36UR4RC8	AUW-36U4RW8	9500	3.65	11000	3.73	9500	6.80	A++	321%	8000	4.30	A+	202%	8000	5.40	A+++	254%	65	69	Φ 9.52/Φ 15.88(3/8/5/8)
AUV105UR4RC8	AUW105U6RW8	AUV-36UR4RC8	AUW-36U6RW8	9500	3.65	11000	3.73	9500	6.80	—	321%	8000	4.30	A+	202%	8000	5.40	A+++	254%	65	74	Φ 9.52/Φ 15.88(3/8/5/8)
AUV125UR4RC8	AUW125U4RW8	AUV-42UR4RC8	AUW-42U4RW8	12100	3.41	13500	3.70	12100	6.80	—	269%	8999	4.40	—	173%	9000	5.40	—	213%	71	69	Φ 9.52/Φ 15.88(3/8/5/8)
AUV125UR4RC8	AUW125U6RW8	AUV-42UR4RC8	AUW-42U6RW8	12100	3.41	13500	3.70	12100	6.80	—	269%	9000	4.40	—	173%	9000	5.40	—	213%	71	74	Φ 9.52/Φ 15.88(3/8/5/8)
AUV140UR4RC8	AUW140U4RW8	AUV-48UR4RC8	AUW-48U4RW8	13500	3.21	16000	3.30	13500	6.50	—	257%	9000	4.40	—	173%	9000	5.40	—	213%	71	70	Φ 9.52/Φ 15.88(3/8/5/8)
AUV140UR4RC8	AUW140U6RW8	AUV-48UR4RC8	AUW-48U6RW8	13500	3.21	16000	3.30	13500	6.50	—	257%	9000	4.40	—	173%	9000	5.40	—	213%	71	75	Φ 9.52/Φ 15.88(3/8/5/8)
AUV175UR4RC8	AUW175U6RW8	AUV-60UR4RC8	AUW-60U6RW8	16000	2.65	17500	3.30	16000	5.80	—	229%	10000	3.80	—	149%	10000	5.10	—	201%	72		
AUF175UR4RHPA8	AUW175U6RW8	AUF-60UR4RHPA8	AUW-60U6RW8	16000	3.00	17500	3.80	16000	6.50	—	307%	10000	4.10	—	192%	10000	5.40	A+++	254%	70	75	Φ 9.52/Φ 15.88(3/8/5/8)

# QUICK SEARCH GUIDE

## Super Inverter R32

EU Model (Hisense)		Model		Nominal Capacity				Energy Efficiency/Cooling				Energy Efficiency/Heating Average				Energy Efficiency/Heating Warmer				Sound Power		Pipe Size
Indoor Unit	Outdoor Unit	Indoor Unit	Outdoor Unit	Cooling(W)	EER(W/W)	Heating(W)	COP(W/W)	Pdc(W)	SEER	Energy Level	$\eta$ s,c	Pdh(W)	SCOP	Level	$\eta$ s,h	Pdh (W)	SCOP	Level	$\eta$ s,h	IDU(dB)	ODU(dB)	Gas/Liquid(mm)
ACT40UR4RCC8	AUW40U4RS7	ACT-14UR4RCC8	AUW-14U4RS7	4100	3.87	4600	3.90	4100	7.00	A++	330%	4000	4.10	A+	192%	4000	5.40	A+++	254%	57	63	Φ6.35/Φ12.7(1/4"/1/2")
ACT52UR4RCC8	AUW52U4RS7	ACT-18UR4RCC8	AUW-18U4RS7	5000	3.40	5500	3.72	5000	6.40	A++	302%	4000	4.10	A+	192%	4000	5.40	A+++	254%	57	63	Φ6.35/Φ12.7(1/4"/1/2")
ACT40UR4RJC8	AUW40U4RS7	AUC-14UR4RJC8	AUW-14U4RS7	4100	4.10	4600	4.50	4100	7.20	A++	340%	4000	4.40	A+	207%	4000	5.35	A+++	252%	52	63	Φ6.35/Φ12.7(1/4"/1/2")
ACT52UR4RJC8	AUW52U4RS7	AUC-18UR4RJC8	AUW-18U4RS7	5000	3.70	5500	4.20	5000	7.10	A++	335%	4000	4.40	A+	207%	4000	5.35	A+++	252%	52	63	Φ6.35/Φ12.7(1/4"/1/2")
ACT60UR4RJC8	AUW60U4RJ7	ACT-21UR4RJC8	AUW-21U4RJ7	6200	3.71	7300	3.80	6200	7.20	A++	340%	5500	4.10	A+	192%	5500	5.35	A+++	252%	54	68	Φ9.52/Φ15.88(3/8"/5/8")
ACT71UR4RJC8	AUW71U4RJ7	ACT-24UR4RJC8	AUW-24U4RJ7	7000	3.40	8000	3.72	7000	7.00	A++	330%	5500	4.10	A+	192%	5500	5.35	A+++	252%	54	68	Φ9.52/Φ15.88(3/8"/5/8")
AUC105UR4RKC8	AUW105U4RK7	AUC-36UR4RKC8	AUW-36U4RK7	10000	3.23	11000	3.72	10000	6.20	A++	292%	8000	4.00	A+	187%	8000	5.31	A+++	250%	62	69	Φ9.52/Φ15.88(3/8"/5/8")
ADT40UX4RCL8	AUW40U4RS7	ADT-14UX4RCL8	AUW-14U4RS7	4100	3.80	4600	4.10	4100	7.00	A++	330%	4000	4.30	A+	202%	4000	5.40	A+++	254%	57	63	Φ6.35/Φ12.7(1/4"/1/2")
ADT52UX4RCL8	AUW52U4RS7	ADT-18UX4RCL8	AUW-18U4RS7	5000	3.50	5500	3.79	5000	7.00	A++	330%	4000	4.30	A+	202%	4000	5.40	A+++	254%	57	63	Φ6.35/Φ12.7(1/4"/1/2")
ADT71UX4RCL8	AUW71U4RJ7	ADT-24UX4RCL8	AUW-24U4RJ7	7000	3.10	8000	3.33	7000	6.30	A++	297%	5500	4.10	A+	192%	5500	5.40	A+++	254%	58	68	Φ6.35/Φ12.7(1/4"/1/2")
AUD105UX4RQM8	AUW105U4RK7	AUD-36UX4RQM8	AUW-36U4RK7	10000	3.30	11000	3.72	10000	6.40	A++	302%	7400	4.00	A+	187%	7400	5.40	A+++	254%	59	69	Φ9.52/Φ15.88(3/8"/5/8")
AUD105UX4REH8	AUW105U4RK7	AUD-36UX4REH8	AUW-36U4RK7	10000	3.30	11000	3.75	10000	6.10	A++	287%	8000	4.00	A+	187%	8000	5.35	A+++	252%	59	69	Φ9.52/Φ15.88(3/8"/5/8")
AVT60UR4RB8	AUW60U4RJ7	AVT-21UR4RB8	AUW-21U4RJ7	6200	3.41	7300	3.80	6200	6.70	A++	316%	5500	4.20	A+	197%	5500	5.35	A+++	252%	62	68	Φ9.52/Φ15.88(3/8"/5/8")
AVT71UR4RB8	AUW71U4RJ7	AVT-24UR4RB8	AUW-24U4RJ7	7000	3.24	8000	3.72	7000	6.30	A++	297%	5500	4.20	A+	197%	5500	5.35	A+++	252%	62	68	Φ9.52/Φ15.88(3/8"/5/8")
AUV105UR4RC8	AUW105U4RK7	AUV-36UR4RC8	AUW-36U4RK7	9500	2.85	11000	3.40	9500	6.10	A++	287%	8000	4.00	A+	187%	8000	5.31	A+++	250%	65	69	Φ9.52/Φ15.88(3/8"/5/8")
AKT40UR4RK8	AUW40U4RS7	AKT-14UR4RK8	AUW-14U4RS7	4100	3.80	4500	3.54	4100	7.00	A++	330%	3500	4.10	A+	192%	3500	5.40	A+++	254%	59	63	Φ6.35/Φ12.7(1/4"/1/2")
AKT52UR4RK8	AUW52U4RS7	AKT-18UR4RK8	AUW-18U4RS7	4900	3.31	5000	3.50	4900	6.50	A++	307%	3500	4.10	A+	192%	3500	5.40	A+++	254%	59	63	Φ6.35/Φ12.7(1/4"/1/2")
AUF71UR4RCPA8	AUW71U4RJ7	AUF-24UR4RCPA8	AUW-24U4RJ7	7000	3.21	8000	3.72	7000	6.30	A++	297%	5500	4.10	A+	192%	5500	5.10	A+++	240%	61	68	Φ9.52/Φ15.88(3/8"/5/8")
AUF105UR4RMPA8	AUW105U4RK7	AUF-36UR4RMPA8	AUW-36U4RK7	10000	3.21	11000	3.72	10000	6.20	A++	292%	7400	4.00	A+	187%	7400	5.20	A+++	245%	61	69	Φ9.52/Φ15.88(3/8"/5/8")
AUF140UR4RMPA8	AUW140U6RQ7	AUF-48UR4RMPA8	AUW-48U6RQ7	13500	2.90	14500	3.54	13500	6.20	-	292%	8500	4.00	A+	187%	8500	5.10	A+++	240%	63	75	Φ9.52/Φ15.88(3/8"/5/8")

# CONTROL SYSTEM

## Wired Controller & Central Controller



### YXE-CO1U2(E)

YXE-CO1U2(E) is YXE-CO1U1(E) pro, and base on YXE-CO1U1(E) some special functions have been added on , such as heating only setting, humidity display in dry mode etc.



### YXE-CO1U1(E)

YXE-CO1U1(E) is YXE-CO1U Pro, with the optimize of the setting method of some special functions. For Example, cooling only setting, Boot setting etc.



### YXE-E01U(E)

YXE-E01U(E) is brand new wired controller, replace YXE-A03 series, with the optimize of many functions. For Example, Independent control function of air louver can be realized.



### YJE-C01T(E)

YJE-C01T(E) can control IDUs by B544(E).



### B545(E)

It is a communicating box called B545(E), which used in central control system. One IDU uses one B545(E), and B545(E) is the adapter that works in KNX with E-Mode.



### B544(E)

It is a communicating box used in central control system. One IDU uses one B544(E). Adapter of the combination of B544(E) & B542(E) & B543(E) \*B544(E) is the adapter of BACnet, Modbus, Twin System.

## Communication Box

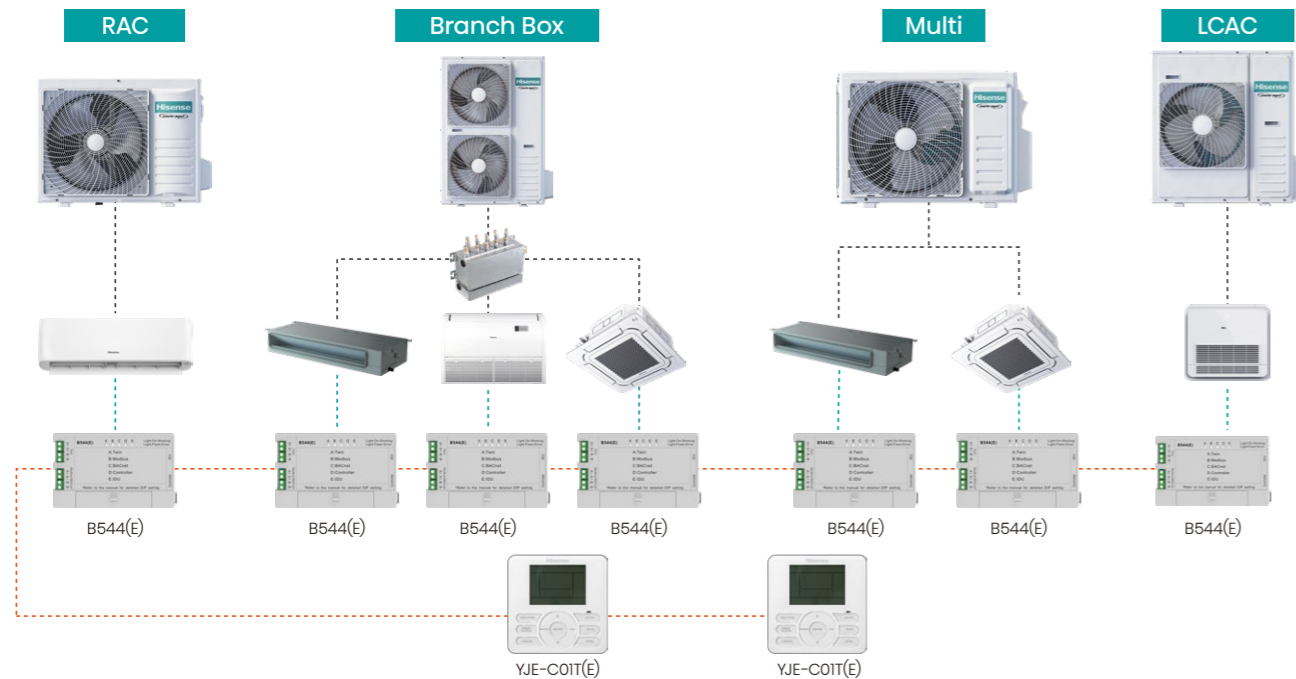

----- : U-art communication protocol. The maximal quantity of controller is 16 in one same system.

----- : RS 485 & BACnet protocol.

YJE-C01T(E): The maximal quantity of centralized controller is 2.

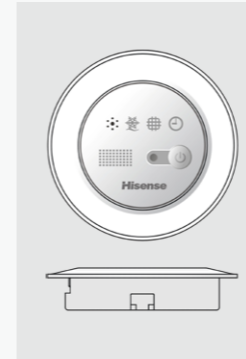

### R-A01Z(E)

Remote receiver kit, can work together with wired controller.



### HLZX-02A

LCAC AHU Kit

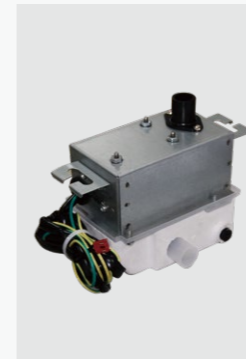

### Pump P-16

External pump, used for AC without internal pump.



### Pump P-12

Semi-external pump, used for AC without internal pump.



### C551

Repeater



### HCPC-H3C1

H-Link Adapter

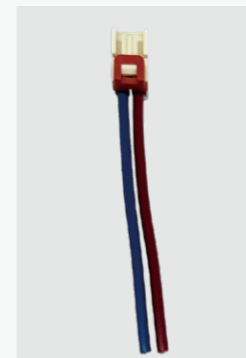

### 12V DC output kit

HS 2089912



### HI-NANO-01A(E)

LCAC HI-NANO

## Connecting Pipes

HS1932947, 6.35mm&9.52mm, 5m  
 HS1932996, 6.35mm&12.7mm, 5m  
 HS1805376, 6.35mm&15.88mm, 5m

HS1805597, 9.52mm&15.88mm, 5m  
 HS1530487, 9.52mm&19.05mm, 5m

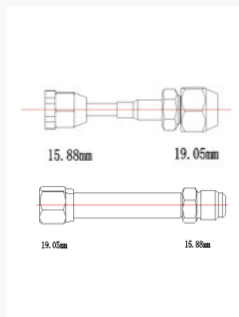
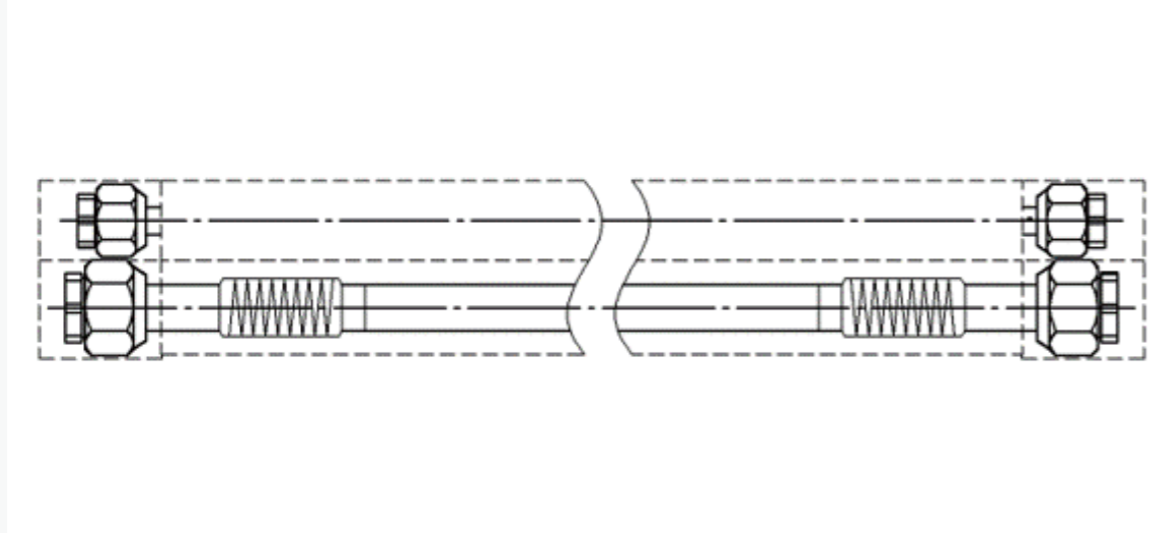

### Pipe Adapter

HS1931361, from 15.88mm to 19.05mm  
 HS1894684, from 19.05mm to 15.88mm

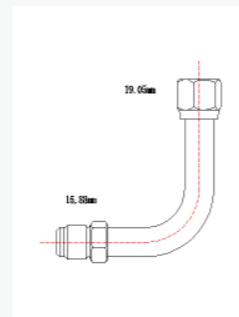

### Pipe Adapter L

HS2019577, from 19.05mm to 15.88mm

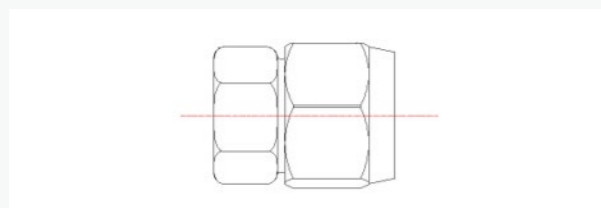

### Adapter

HS2014749, from 9.52 to 15.88

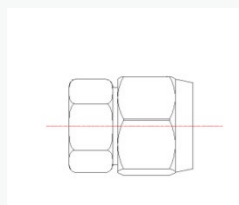

### Adapter

HS1493010, from 9.52mm to 12.7mm

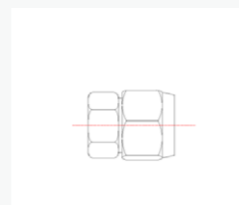

### Adapter

HS2014748, from 6.35mm to 9.52mm

	YXE-E01U(E)	YXE-C01U1(E)	YJE-C01T(E)
<b>Main Function</b>			
Max Connectable Indoor Unit	1	1	16
Modes	●	●	●
Temperature Setting	●	●	●
Timer	●	●	●
Sleep	●	●	●
Weekly Schedule	-	●	●
Error Code Display	●	●	●
One Error Shielded	●	●	●
Check	●	●	●
Wireless Remote Receive	●	●	-
Wireless Remote Receive Forbid	-	●	-
Touch Lock/Bottom Lock	●	●	●
Operation Monitor	●	●	●
Filter Cleaning Remind	●	●	●
Filter Cleaning Timing	●	●	●
C/F	●	●	●
Temperature Display switching	●	●	●
Clock	-	●	●
Mode Lock	●	●	●
Temperature Range Limit	●	●	●
Temperature Range Limit Forbid	-	●	●
Central & Group Controlled	-	-	-
Central & Group Controller	-	-	●
Adress Setting (For Being Controlled)	-	●	●
Simplified Central Controller	-	-	-
I Feel	●	●	●
Temperature Compensation	●	●	●
Temperature Compensation Forbid	-	●	●
High Ceiling Function	●	●	●
Duct Static Pressure Setting	●	●	●
On-off Setting	●	●	●
Auto Restart	●	●	●
Alarm On or Off	●	●	●
Dimer	●	●	●
Mute	-	●	●
Powerful	-	●	●
Up and Down Swing	●	●	●
Left and Right Swing	●	●	●
<b>Features</b>			
LCD Screen	●	●	●
Compact 86×86×15	●	-	-
Big 120×120×20	-	●	●
<b>Power Supply</b>			
DC 12-17V	●	●	-
AC 175-264V	-	-	●
Distance to the Indoor Unit	40m	40m	40m
Built-in Backup Power	-	-	-
<b>Communicate</b>			
BACnet	-	-	●



