

Hisense HVAC

Hisense



Qingdao Hisense HVAC Equipment Co., Ltd.
Hisense International Center, Qingdao, China

<http://www.hisensehvac.com> hisensehvac@hisense.com [Hisense HVAC](#) [Hisense HVAC](#) [Hisense HVAC](#)

HCAC-VRF-EURO202601

★ Design and specifications are subject to change without notice. Pictures and diagrams are for reference only and are subject to change without notice.
All rights reserved by Qingdao Hisense HVAC Equipment Co., Ltd.

Reimagine your solution





Hisense participates in the ECP programme for VRF. Check ongoing validity of certificate: www.eurovent-certification.com

Hisense HVAC

GLOBAL NETWORK

Hisense is a global corporation with its presence in 160 countries and regions worldwide, with over 100,000 employees, 26 R&D centers, 34 industrial parks, 66 overseas companies and 6 AC training centers. Hisense covers different industry divisions and product groups, from consumer electronics, home appliances, IT solutions to real estate business. Driven by the vision to become a reliable, century-old enterprise, we are committed to delivering intelligent solutions that enhance the life quality and well-being of our consumers.

 100000+ Employees	 101 Laboratories	 4916 Authorized Patents
 8000+ Doctoral And Master's Degree Holders	 300+ Testing Equipments	 7 Technological Invention Award



- ▼ Industrial Park
- R&D Center



QingDao · China



ShunDe · China



SPORTS MARKETING

Hisense is committed to enhancing global brand awareness through a visionary, long-term sports marketing strategy. By successfully sponsoring UEFA EURO and FIFA World Cup, Hisense has brought cutting-edge technologies and passion for sports to fans worldwide. With every tournament, Hisense connects millions, inspires excellence, and drives innovation.

Promote Sponsorship of Sport Events to Enhance Global Image



Global Official Sponsor of FIFA World Cup 2026™



2026

Global Official Partner of UEFA EURO 2024™



2024

Global Official Partner of UEFA EURO 2020™

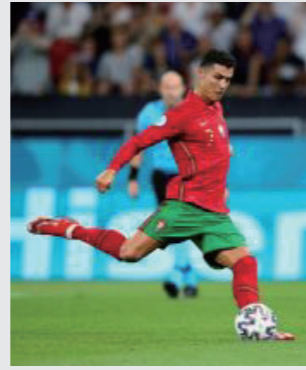

2020

Global Official Partner of UEFA EURO 2016™

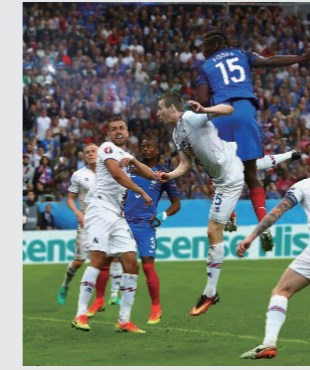

2016

Official Premium Partner of FC Schalke 04



Official Sponsor Of Australian Open



2014

2025



Global Official Sponsor of FIFA Club World Cup 2025™

2022

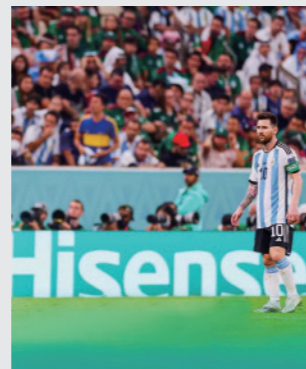

Global Official Sponsor of FIFA World Cup Qatar 2022™

2018



Global Official Sponsor of FIFA World Cup Russia 2018™

2015



Team Supplier to Red Bull Racing F1 Team



Title Sponsor of Hisense 300 NASCAR Xfinity Series & Team Sponsor of Joe Gibbs Racing

2008

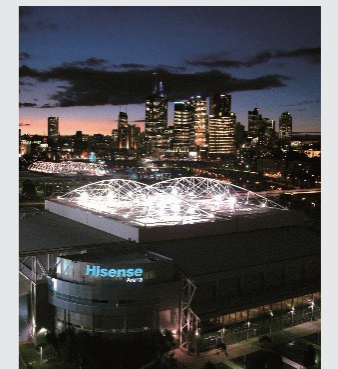

Official Naming Rights to Hisense Arena

HVAC MANUFACTURING

Hisense HVAC is an industry-leading brand that integrates product development, manufacturing, sales, and after-sales service for heating, ventilation, and air conditioning equipment. Its R&D centers, manufacturing bases, and training centers are deployed globally to better serve our customers worldwide. Hisense HVAC is committed to providing excellent products and solutions, contributing to improved air quality for people and advancing green and low-carbon development for the planet.



📍 Qingdao, China



1,171,000 m²
Manufacturing Area



80+
Production Line



30,000,000 units/y
Production Capacity



16,700 m²/70+
Laboratory



📍 Jiangmen, China



📍 Huzhou, China



📍 Thailand



The Guiding Light of Manufacturing
The World's First
VRF Dual-Lighthouse Factory

Smart Manufacturing

Automated Welding

- 57% reduction in welding defects
- Multi-spot welding

Automatic Production

- 1st horizontal inclined automatic tube insertion machine in the industry
- 17 AI High-precision cameras visual guidance

Automated Assembly

- Industry-1st intelligent detection, selection and assembly system
- Labor-saving & error-reducing

Smart Supply Chain

26.66 Average lead days for export order

AI-powered Workflow

- GenAI-based employee assistant
- Real-time alerts and automated tracking
- Scenario analysis and decision recommendation

Agile Delivery

- KPI-driven digital twin operation platform
- AI-powered demand forecasting
- Data-based production planning

Assured Global Logistics

- 8 large overseas warehouses
- All-round logistics service system
- Strategic partnerships with global leading freight companies

APPLICATION SOLUTIONS

Each application has unique requirements, so there is no one-size-fits-all solution. To ensure optimal performance and user satisfaction, it is essential to select the most suitable units for each scenario, considering factors such as room size, usage patterns, and environmental conditions. By addressing these diverse needs, Hisense always delivers tailored solutions that maximize comfort and efficiency.

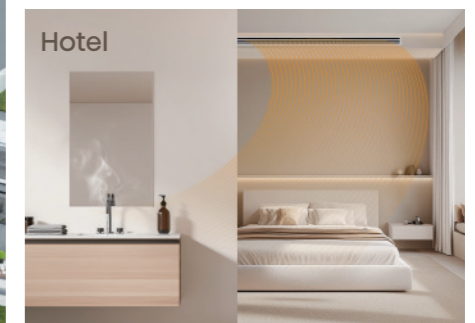
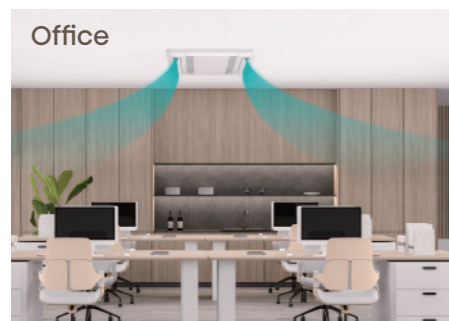

Note: 1.The outdoor units are slightly enlarged for better visibility.
2.Quantity shown is for illustration only and may vary in actual projects.

iCare SUPPORT

Hisense HVAC is dedicated to delivering comprehensive air conditioning solutions and supporting customers at every stage—from product development and pre-sales consultation, to quotation, purchase, installation, commissioning, user experience, and after-sales service. With iCare support, Hisense HVAC further strengthens our commitment to customer satisfaction.



Informative Platform

Hisense has built the technical platform matrix which includes the product selection software, CAD Hi-Design software, BIM, service platforms GCSS, GSD, GKP, etc.



Customer-oriented Localization

Hisense HVAC boasts over 50 technical and service teams strategically positioned worldwide to offer prompt local support. With more than 5 regional spare parts centers and 20+ national spare parts warehouses, we ensure high-quality and swift spare part supply.



Accessible Training

The Hisense HVAC Academy was founded to offer a range of training courses for our staff and partners, with the goal of consistently enhancing the HVAC expertise of engineers, installers, and service agents.



Reliable Service

We've established a comprehensive omni-channel after-sales service system, ensuring reliable assistance anytime and anywhere.



Excellent User Experience

Hisense not only serves as the business's service provider but also delivers outstanding products designed to enhance user experience. By promoting the application of Cloud AI and NFC technologies, Hisense ensures more intelligent, convenient, and seamless solutions for our customers.



CONTENTS



25
COMFORT



41
OUTDOOR UNITS

Hi-FLEXi S5 Series	-43
Hi-FLEXi S Series Heat Recovery (Standard/High Efficiency)	-61
Hi-FLEXi S mavo+ Series	-88
Hi-Smart H5 Series	-101
Hi-Smart A Series	-110
Hi-Smart L+ C+ Series	-116
Hi-Smart H Series	-122



03
RELIABILITY

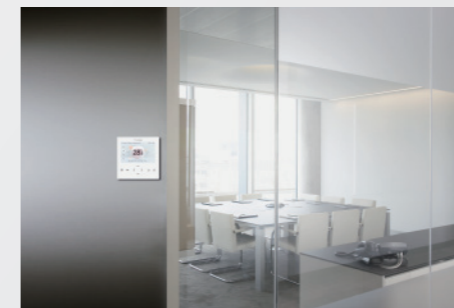

167
CONTROL SYSTEMS

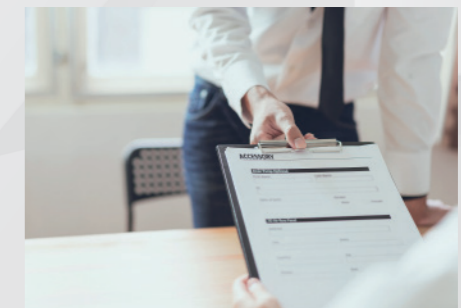

185
ACCESSORIES

EFFICIENCY
17



FLEXIBILITY
33



INDOOR UNITS
127



4-Way Cassette / Mini 4-Way Cassette	-131
1-Way Cassette	-135
2-Way Cassette	-137
Console	-139
Ceiling Ducted (AC/DC Low-height)	-142
Ceiling Ducted (High/Low Static Pressure)	-145
Wall Mounted	-151
Floor Standing	-153
Ceiling & Floor	-155
Floor Concealed	-157
All Fresh Air Indoor Unit	-159
Heat Recovery Ventilator	-161
AHU Connection KIT	-165



Hi-FLEXi S5 Series



Hi-FLEXi S Series Heat Recovery (Standard)

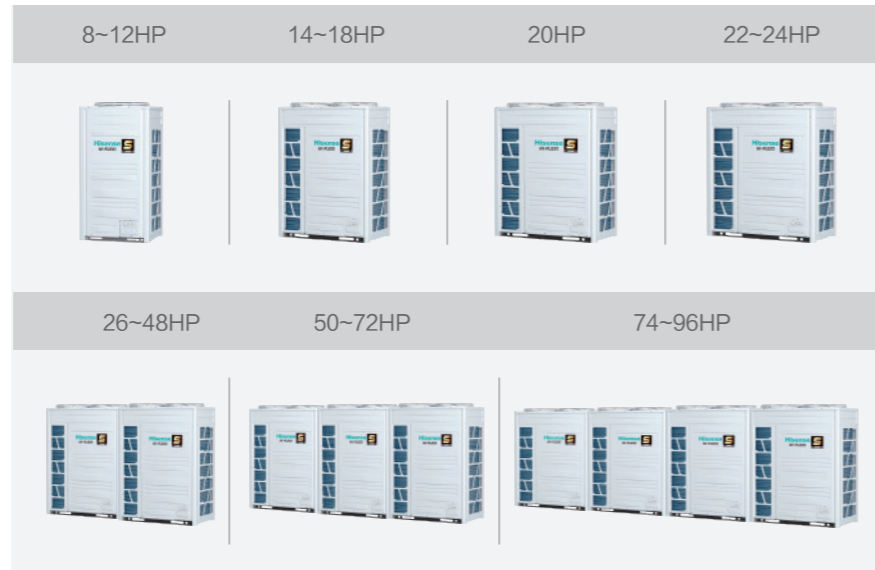

Hi-FLEXi S Series Heat Recovery (High Efficiency)

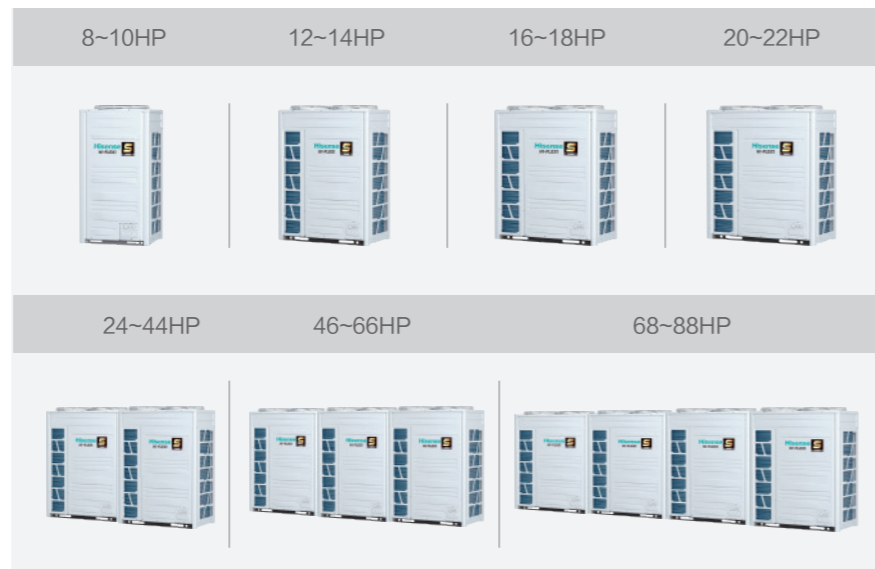

Hi-FLEXi S mavo+ Series

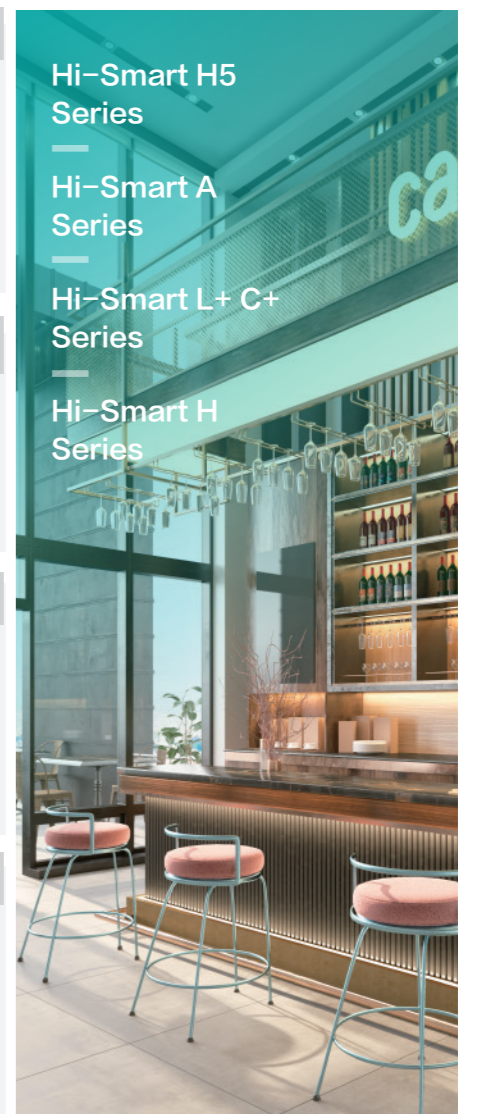

Hi-Smart H5 Series



Hi-Smart A Series



Hi-Smart L+ C+ Series



Hi-Smart H Series

Hisense VRF

RELIABILITY

Refrigerant Circuit

Enhanced Anti-corrosion Solution

System & Operation

Electrical & Electronics

Indoor Unit Reliability

AIR
CONDITIONING
SOLUTION

Refrigerant Circuit

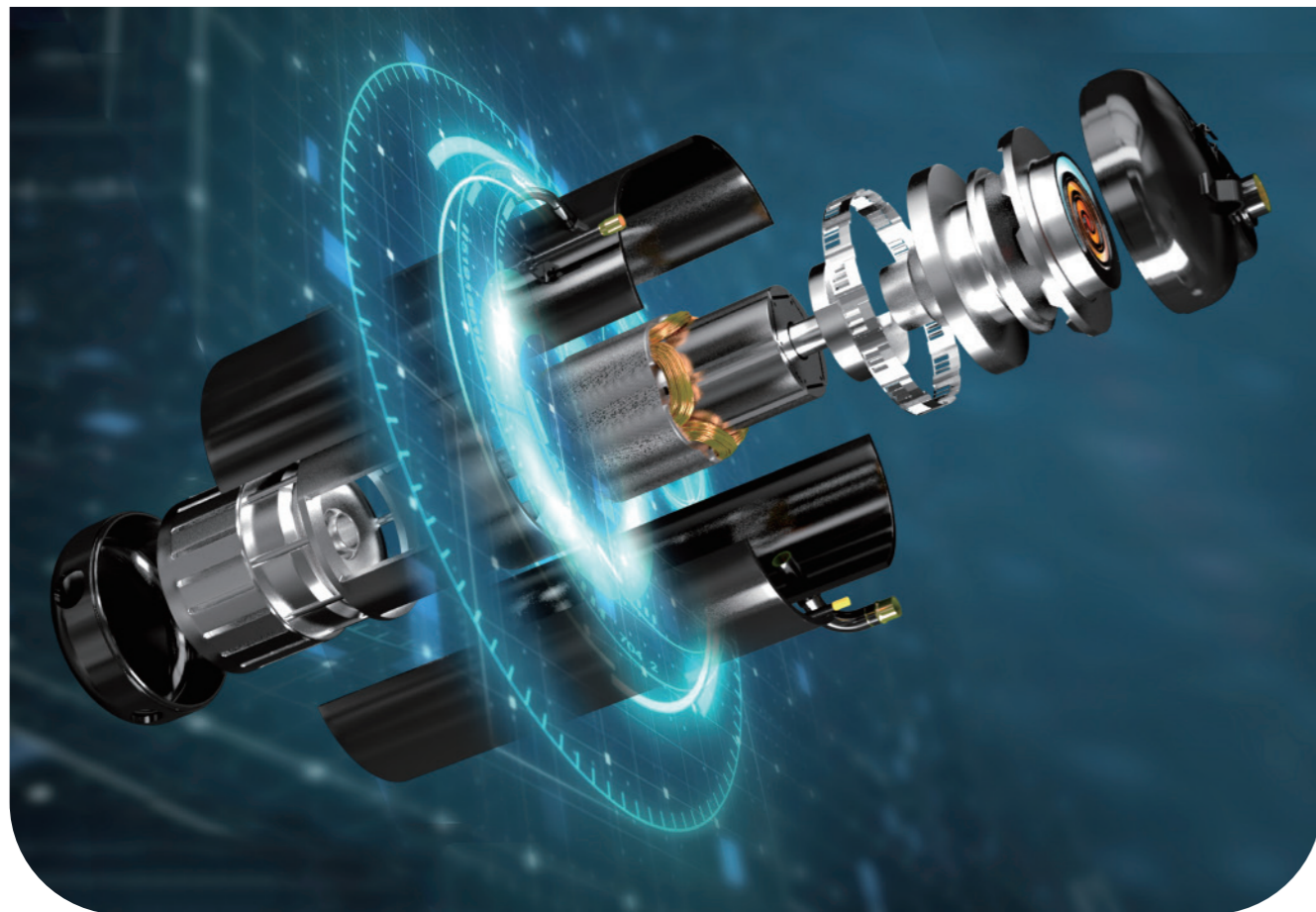

Efficient energy usage

Wasted power is reduced by minimizing leakage and anti-overcompression while compressing refrigerant gas with asymmetric scroll and patented release valves.

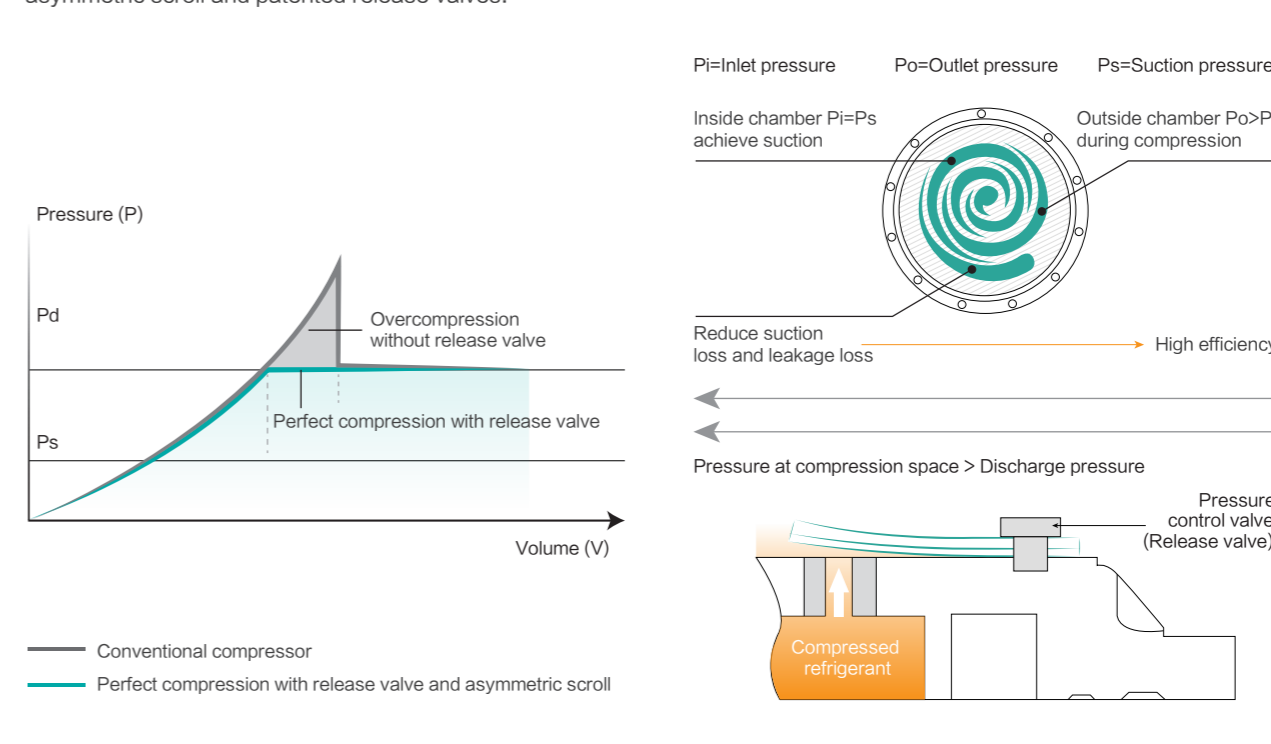

Revolutionary HVAC compressor

Vapour injection technology

New generation scroll compressor is now patented with higher performance capability vapour injection technology, increasing capacity up to 25% compared to conventional scroll compressor with same amount of power consumed.

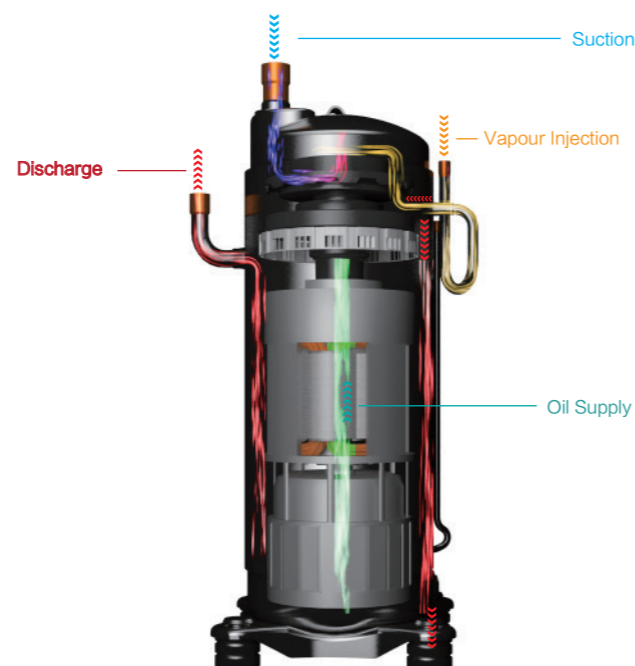

Enhanced oil level retaining capability

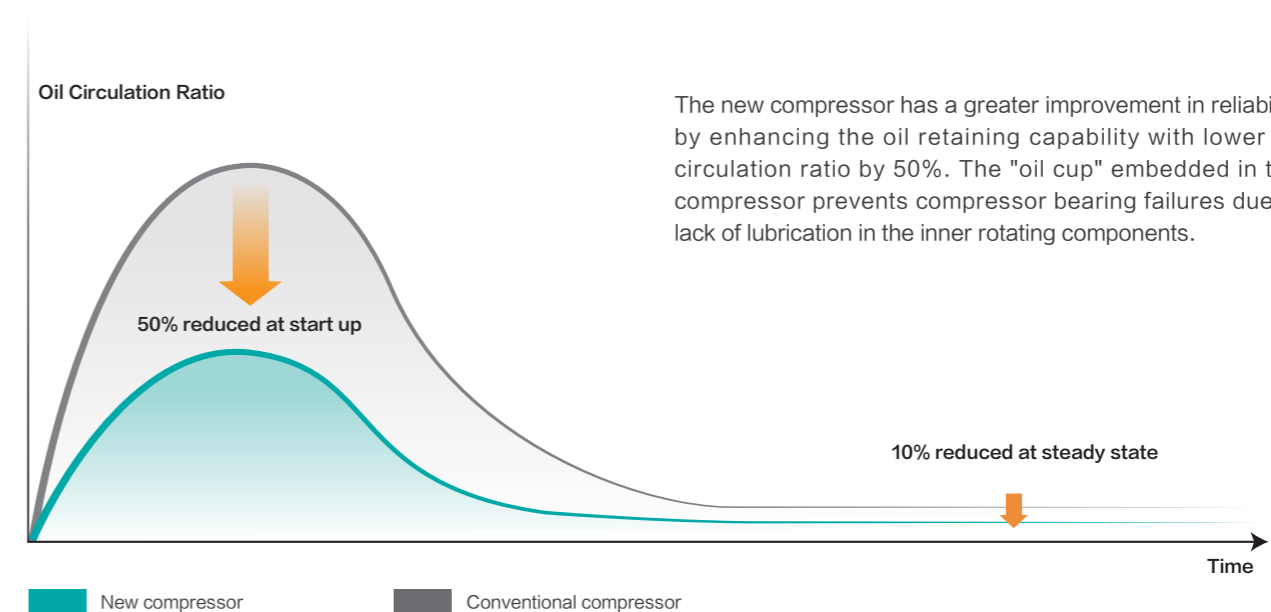

The new compressor has a greater improvement in reliability by enhancing the oil retaining capability with lower oil circulation ratio by 50%. The "oil cup" embedded in the compressor prevents compressor bearing failures due to lack of lubrication in the inner rotating components.

Oil separation and oil return

Oil separation

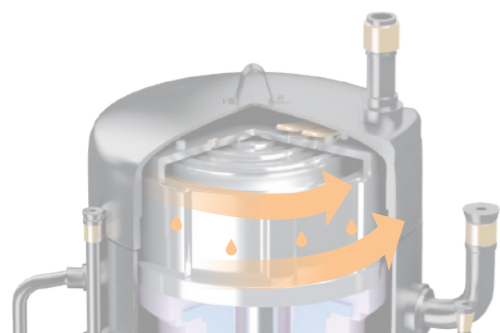

First-stage Oil Separation

First-stage oil separation is realized through efficient oil separation structure inside the high-pressure-chamber compressor. Only a small amount of oil is brought out of the compressor.

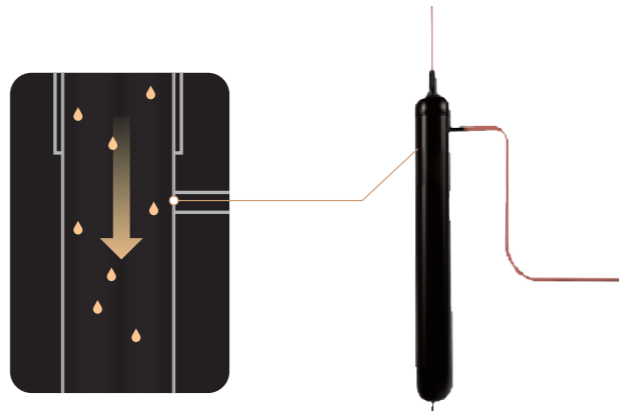

Second-stage Oil Separation

During second-stage oil separation, the small amount of oil discharged from compressor is separated by a large-capacity high-efficiency centrifugal oil separator, with efficiency over 99%.

Oil return

The accumulator adopts pore tube oil return technology with a built-in fine strainer, which not only ensures oil balance between compressors within one module, but also plays an important role in the oil balance between modules.

Besides this, the system implements oil-return function based on compressor frequency and corresponding operation time. The oil-return takes 60 seconds and can return to previous condition when it is finished.

In winter under heating mode, this operation is implemented without switching to cooling mode, which guarantees the heating performance.

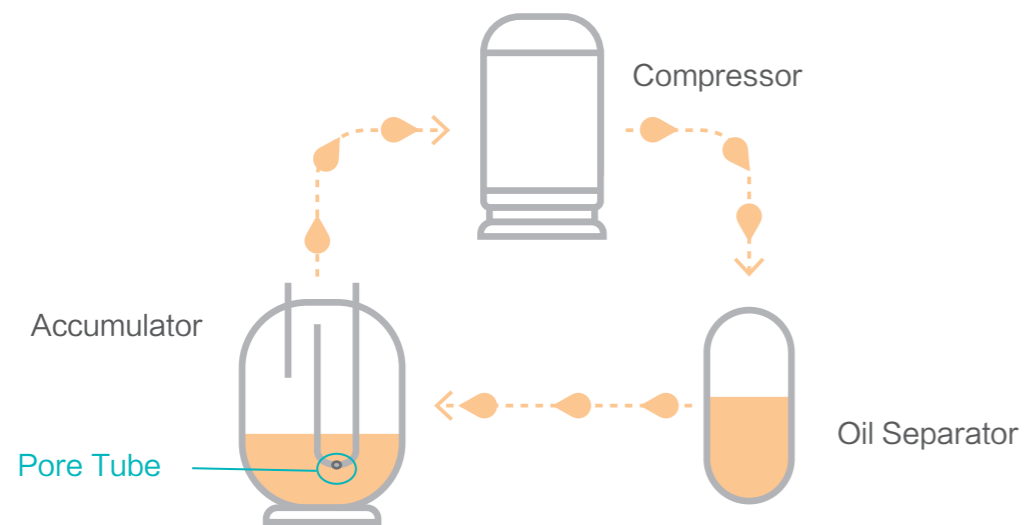

Enhanced Anti-corrosion Solution(optional)



Hisense's complete corrosion-proof is a perfect solution in seaside and chemical factory applications (sulphide contamination occasion), providing ultimate comfort without sacrificing life span and reducing maintenance cost simultaneously.

The components from top to toe are treated with effect treatments, and the systems have acquired UL certification.



- ① **Front Panel** Galvanized steel treated with zirconium & 100 μm ~ 180 μm epoxy zinc rich primer + pure polyester paint coating.
- ② **Heat Exchanger** Dark Gray fin (with epoxy resin and acrylic resin & hydrophilic film); Cooper fin.
- ③ **Electrical Box** Galvanized steel treated with zirconium & 50 μm~120 μm pure polyester.
- ④ **Fan Motor** Coated with 10 μm ~ 30 μm acrylic resin coating Thickness: 10 μm ~30 μm.
- ⑤ **Top Grill**
- ⑥ **Motor Bracket**
- ⑦ **Protection Net**

Note

Please refer to the catalog of Hisense VRF Anti-corrosion Solution for detailed anti-corrosion treatment measures.

System & Operation



Self-diagnosis & self-protection measures

Self-diagnosis

Operation monitoring and maintenance are made simpler by having the AC unit tells you what and where is wrong with them. Alarm codes will be flashed out when an error or breakdown occurs. Extremely helpful for installers during test run and also end-users to understand what's going on. Besides alarm codes, operating status and parameters like history temperature, pressure, compressor frequency and etc are traceable on controllers and the outdoor unit, easing service maintenance and troubleshooting.

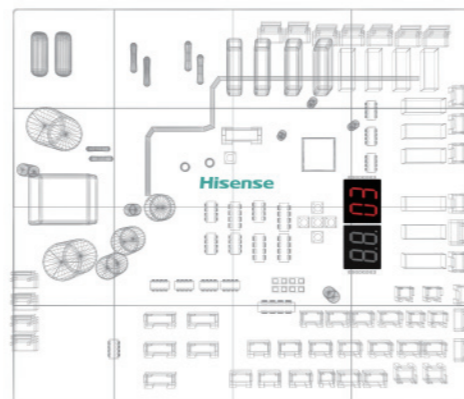

Self-protection

Hisense VRF can protect itself with algorithms embedded to make necessary protective decisions and measures by different sensor readings and parameters, including compressor protections, system protections, inverter protections and electric protections.



Smart rotative operation

Operation duties are smartly balanced in higher capacity module combinations to prevent occurrence of individual unit overworked and hence extending the overall operating life of the overall system.



Multiple backup operation

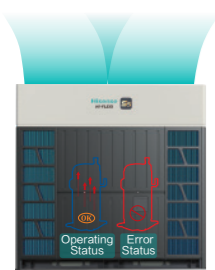

Compressor Backup
If one compressor fails, the other compressor will seamlessly take over for emergency operation without interruption.



Inverter PCB Backup
If one of the inverter PCB fails, the remaining inverters can also continue functioning in an emergency.



Fan Motor Backup
Similarly, if a fan motor fails, the other one can keep working to ensure efficient unit operation.

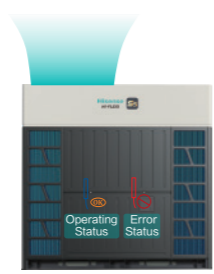

Sensor Backup
Using digital twin technology, virtual sensors are generated based on the built-in pressure and temperature values of the unit, providing mutual backup for emergency operation.

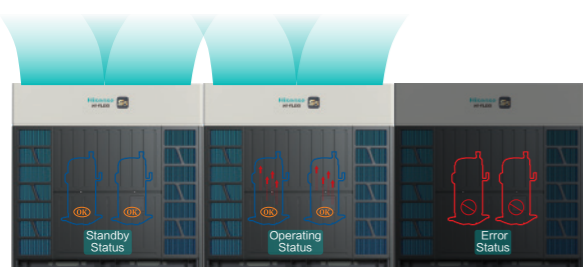

Module Backup
In the case of a module failure within a combination system, the remaining modules are still able to sustain operation in emergency mode.

Snow hood (optional)

The snow hood kit can effectively prevent heavy snow from accumulating on the top of the unit and covering the heat exchanger. Heavy snow accumulating will affect the heat exchange seriously, thus stable operation can be ensured thanks to the snow hood.

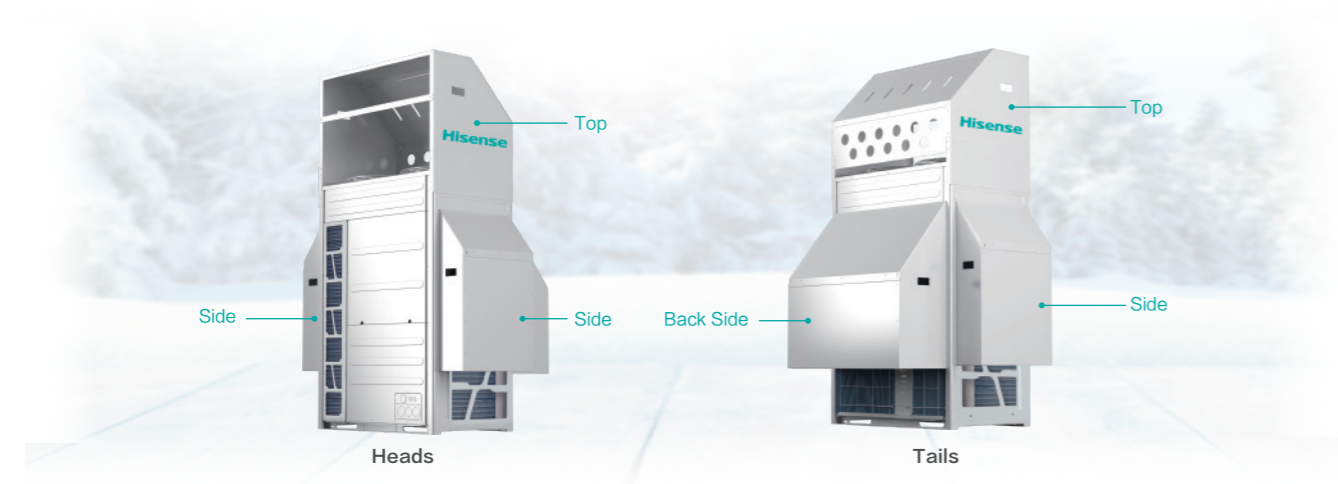

Wider operation range

Extended operation range creates wider application potential, in cooling mode the operation range is from -15°C DB to 55°C DB and in heating mode the operation range is from -30°C WB to 30°C WB, which adapts to extreme conditions.

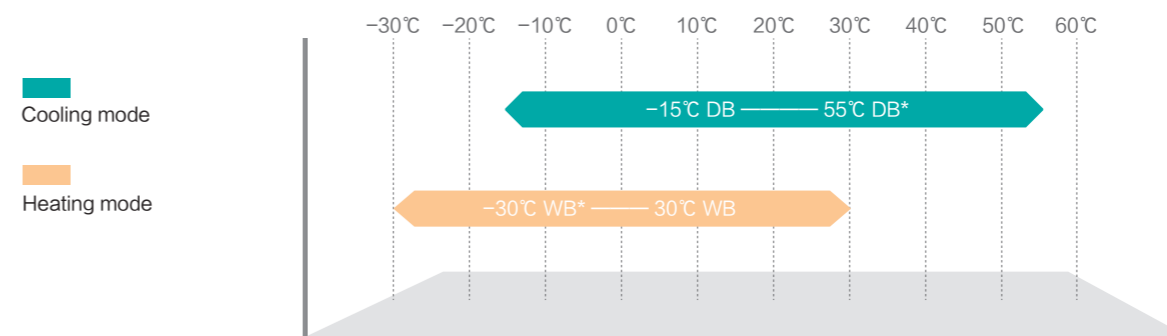

Note

The above data is based on S5 Series. Please refer to the specification of each series for detailed operation range.

Automatic Restart

Hisense indoor units are capable to restart automatically to the previous state whenever the power supply is shut off suddenly and restores immediately. When there is long power shortage, the default setting is to keep all the indoor units off when the power restores. Also there are two other settings for users' choice, recovering to the state before power failure or restarting all the indoor units.

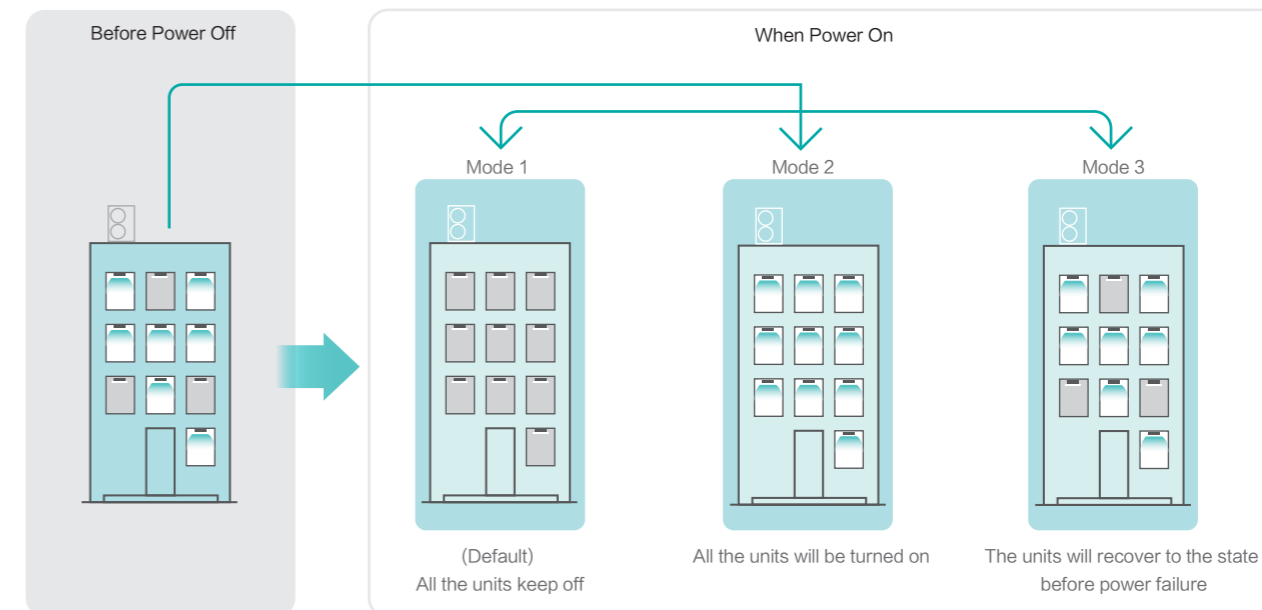

* DIP setting is necessary for mode 2 and mode 3.

Electrical & Electronics

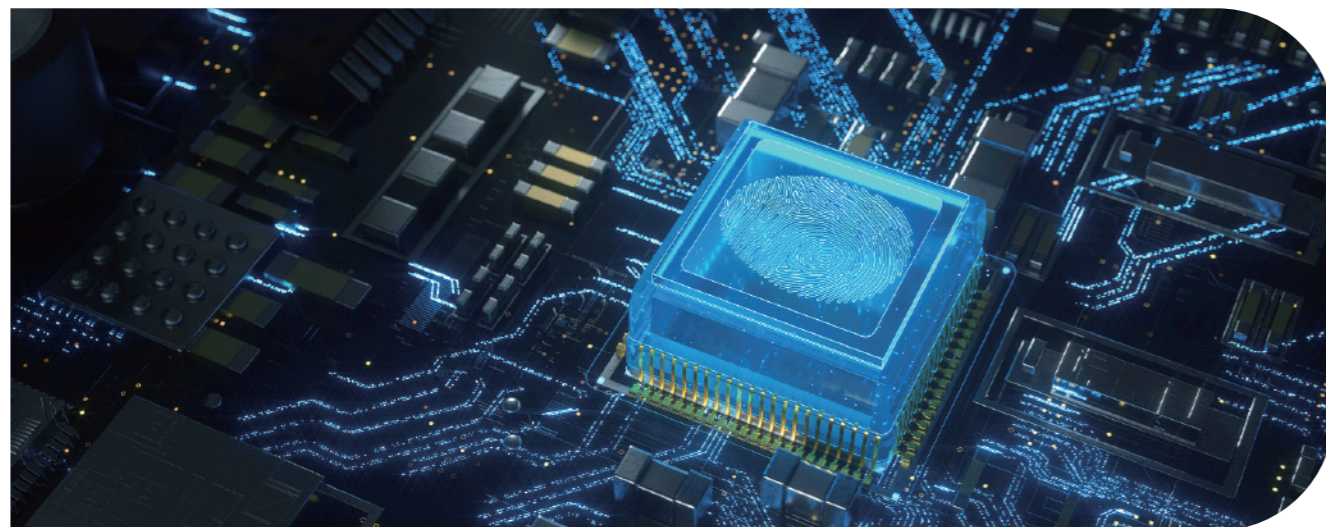

Patented 360° fitted refrigerant cooling technology

Hisense VRF uses refrigerant cooling technology to cool the electrical control box. It overcomes the poor heat dissipation and high ambient temperature issues to maintain efficient operation even at harsh environment. Compared with air-cooled technology, the temperature inside the electrical box can be reduced by up to 20%*. Moreover, the refrigerant cooling kit adds a temperature sensor, which could be more precise to control the refrigerant cooling temperature and ensure the whole reliability.

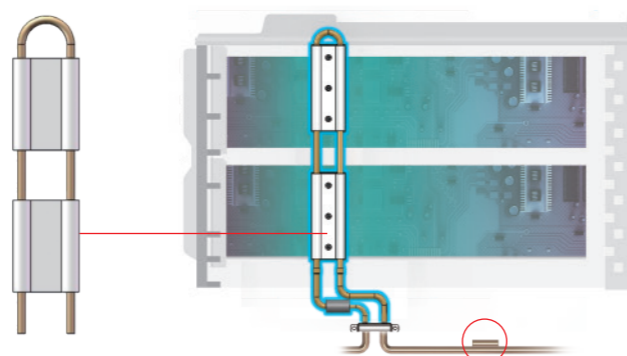

Note

1. * The data is based on the S mavo+ unit under low fan speed operation. 2. Temperature sensor is only available for S mavo+ series.

Insect protection design

Special design nettings are placed on insect easy-entry openings, effectively preventing unnecessary electrical component damages.

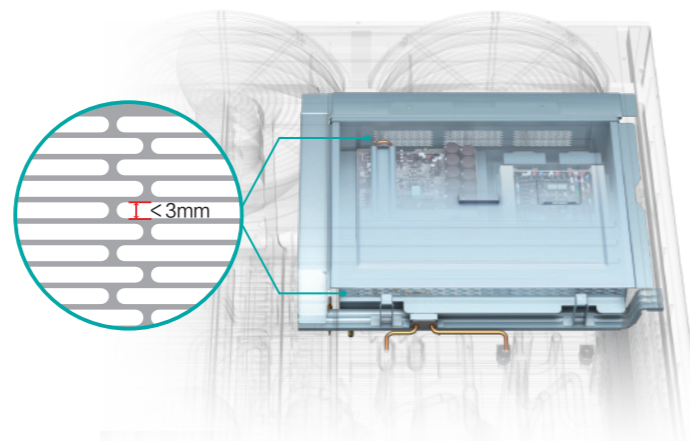

Voltage protector reserved (optional)

Too low or too high voltage can easily damage the electronic components. The new generation of top flow unit has reserved the space for assembling the voltage protector, which can be an effective solution to protect outdoor units from any voltage spikes. The power supply of outdoor unit will be automatically cut off when there is abnormal voltage, and will be restored when power supply returns to normal after 30s. Meanwhile, it's helpful for checking the phase sequence error or phase loss according to the indicator lights, convenient for commission and maintenance.



Can bear **15000** times actions



Can be installed in the factory or on site

Quality electrical and magnetism precaution measure

Air-conditioning unit produced by Hisense VRF requires strict electromagnetic protection and preventive quality assurance to not allow electromagnetic wave from other devices surrounding the unit to interfere the normal operation and function of our unit and vice versa onto other equipment. Another typical damage causes of electronic and electrical failure is sudden high external power source exerted into the electronic compositions like thunder strike during a storm. As to overcome such inevitable natural phenomenon to cause damage, 4000V sudden high voltage test is infused into the long list of electromagnetism quality test in our internationally qualified test lab.



Indoor Unit Reliability



Independent maintenance of indoor unit

To maintain the whole system's continuous operation even when there is a breakdown occurring within the system, Hisense VRF is capable to isolate the faulty unit from the others while conducting restoration and maintaining continuous operation of other units simultaneously. It's especially practical for retail shops or offices where multiple indoor units share the same system.

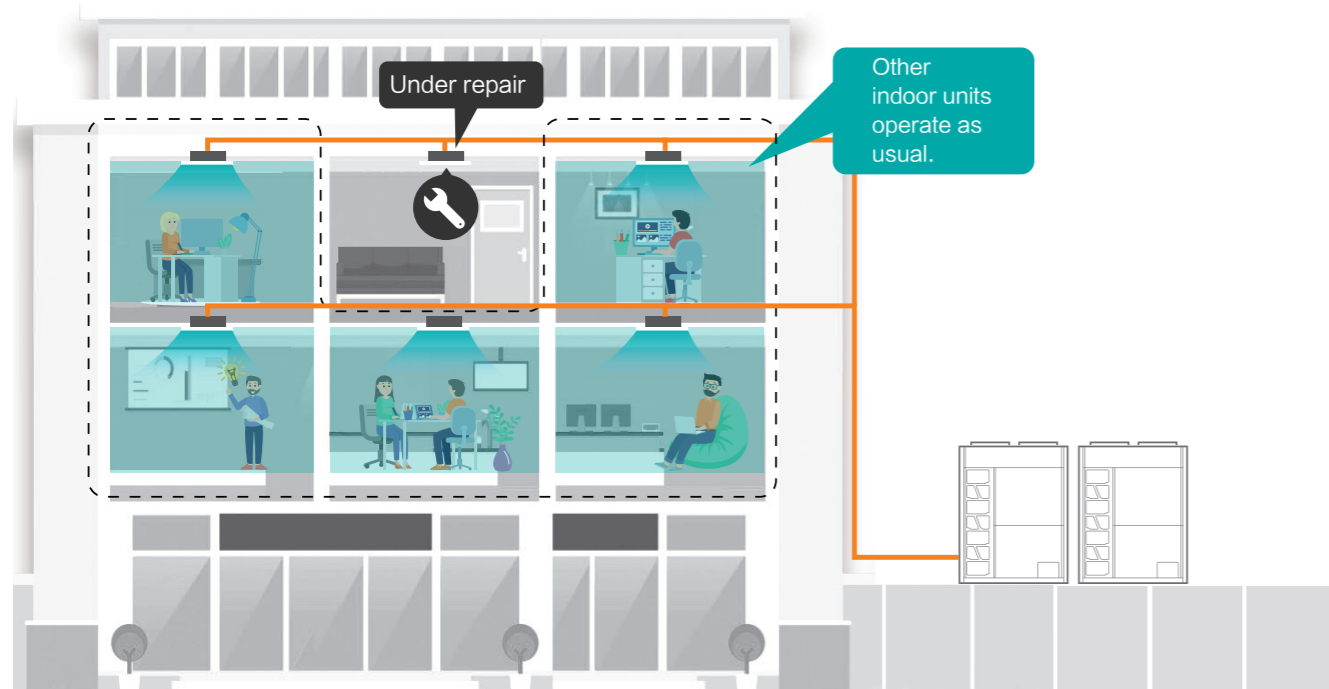

*Preliminary setting is unnecessary

Condensate water leakage protection

Indoor units have build-in water-leakage float switches. Alarming warnings will be displayed on controllers when condensate reaches a certain level. Save your ceiling and carpet from being soaked in time when drain pipe is clogged or drain pump breakdowns.

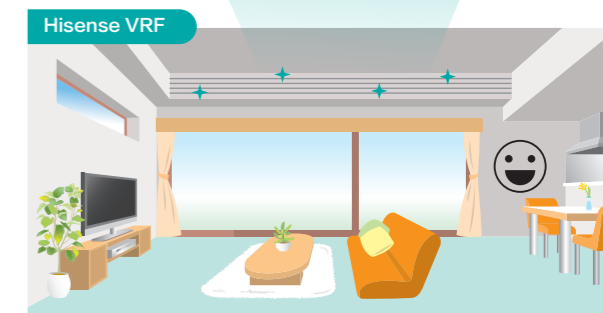
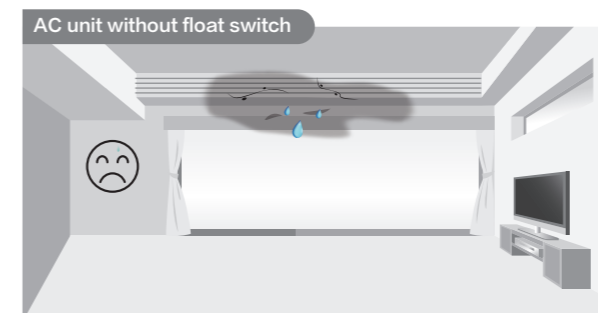
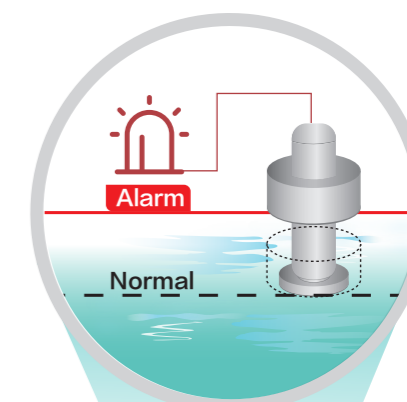

Effective drainage solution

High quality seals

Water could seep through anywhere as long as there is a void. Thus, Hisense utilizes the best quality sealing material to seal up gaps between the heat exchanger and drain pan, which effectively prevents condensate leakage.

Transparent drain pipe

To ease drainage inspection, Hisense indoor units adopt transparent drain hose connection. It enhances installation and maintenance, making sure drain hoses are connected securely and make blockage inspections much easier.

Hisense VRF

EFFICIENCY

Efficient Heat Exchanger

Intelligent Defrosting Logic

Steady Air Discharge

AIR
CONDITIONING
SOLUTION

Efficient Heat Exchanger

New advanced corrugated fin design

The heat exchanger of Hisense VRF adopts the new advanced corrugated fin design. With this new design, larger amount of fins can be allocated into the heat exchanger, increasing 20% heat exchange surface area maximally compared with the last generation fin and the heating capability increase 10% averagely.

Long-time stable heating performance

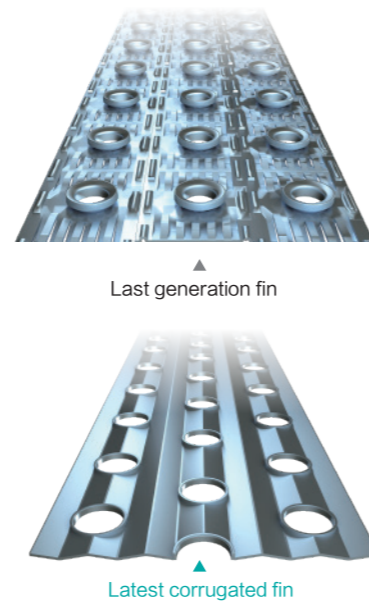
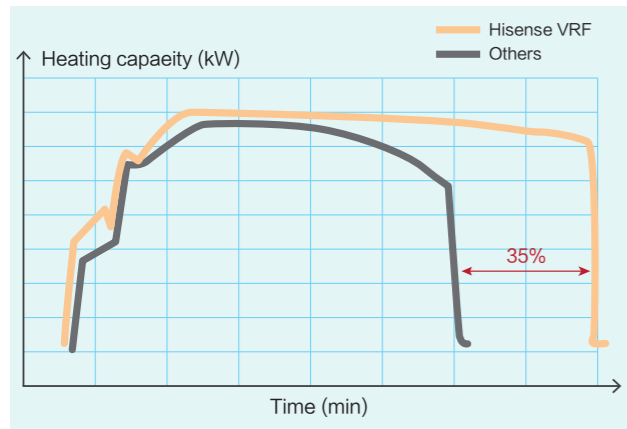

Two-stage subcooling

For the conventional VRF systems without the sub-coolers, the subcooling temperature is about 12.5°C with one-stage subcooling. However, Hisense VRF's 2-stage subcooling technology can realize the subcooling temperature up to 27°C, distinctly improving the cooling capacity by pushing refrigerant further beyond its condensing temperature.

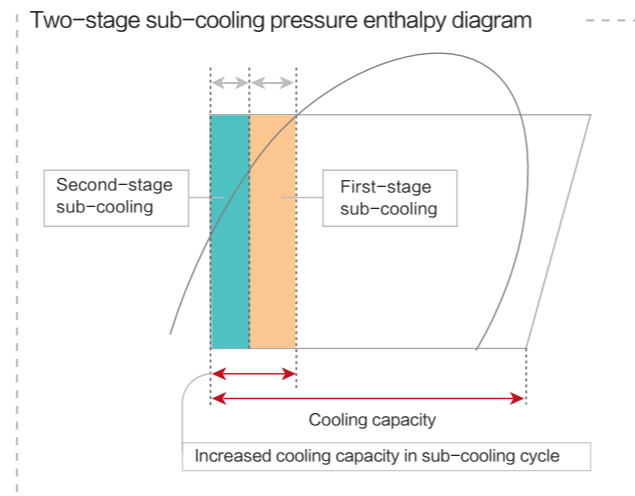
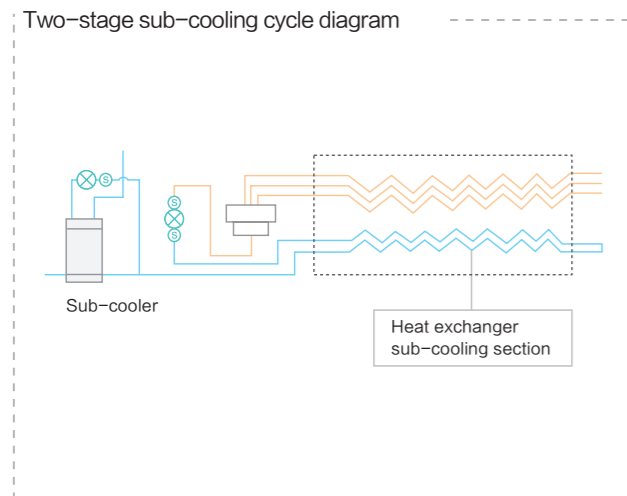

Optimized refrigerant circuit

As refrigerant flows in the system, energy will be lost due to friction and other factors naturally especially when refrigerant change phase, latent heat are lost when gas turns to liquid. Whereby, as more heat is dissipated out, higher the heat exchanger efficiency is. By making full use of heat dissipation, refrigerant flow layout is maneuvered into 2 to 1 refrigerant flow path extends liquid refrigerant's occupancy and eventually the efficiency too.

Conventional technology

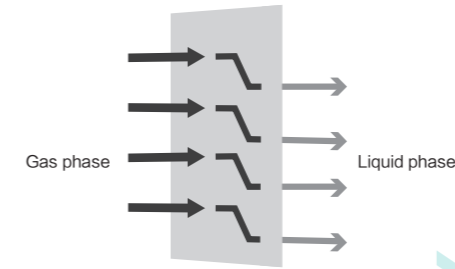

2-to-1 refrigerant flow path

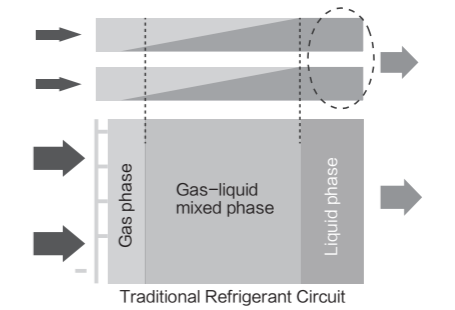
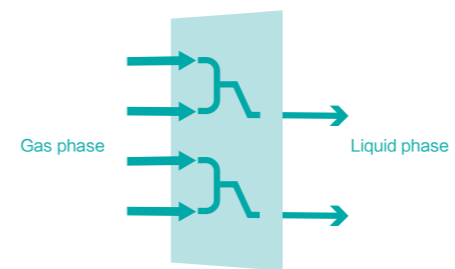

Gas Refrigerant Liquid Refrigerant

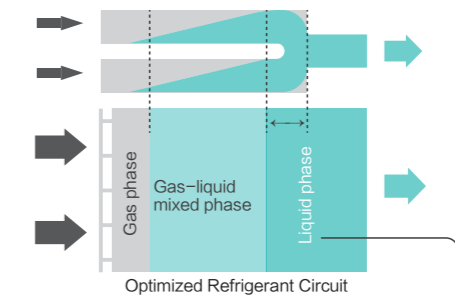

Increase the proportion of liquid refrigerant in the heat exchanger to improve heat transfer efficiency

Gas Refrigerant Liquid Refrigerant

Why does 2 to 1 refrigerant circuit is higher in efficiency?

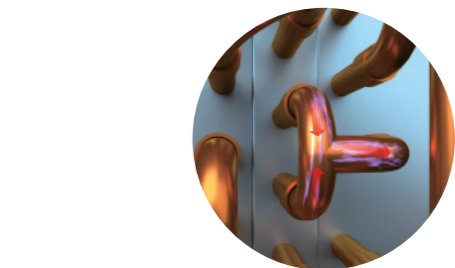
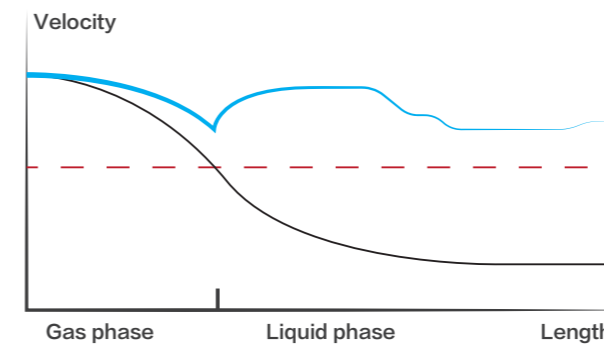

2 to 1 refrigerant circuit: velocity is maintained same goes to the efficiency of refrigerant heat exchange.
 Conventional refrigerant circuit: Heat exchange slows down with decreased velocity. Efficiency is greatly reduced.

Intelligent Defrosting Logic

PTT defrosting mode

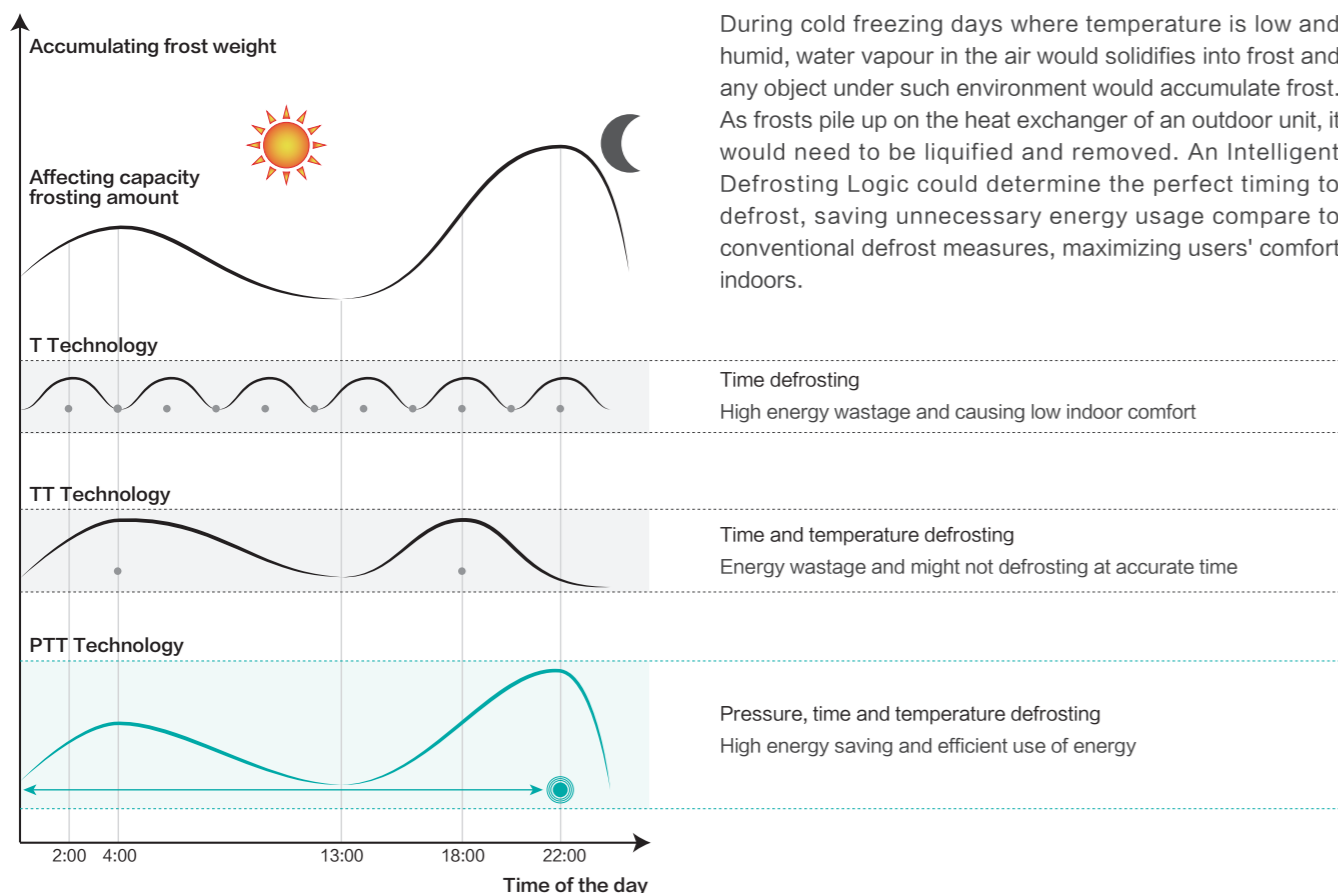

During cold freezing days where temperature is low and humid, water vapour in the air would solidifies into frost and any object under such environment would accumulate frost. As frosts pile up on the heat exchanger of an outdoor unit, it would need to be liquified and removed. An Intelligent Defrosting Logic could determine the perfect timing to defrost, saving unnecessary energy usage compare to conventional defrost measures, maximizing users' comfort indoors.

Continuous heating during defrost

The module combination design can achieve rotation defrosting among modules for decreasing indoor temperature fluctuation, so as to improve users' comfort.

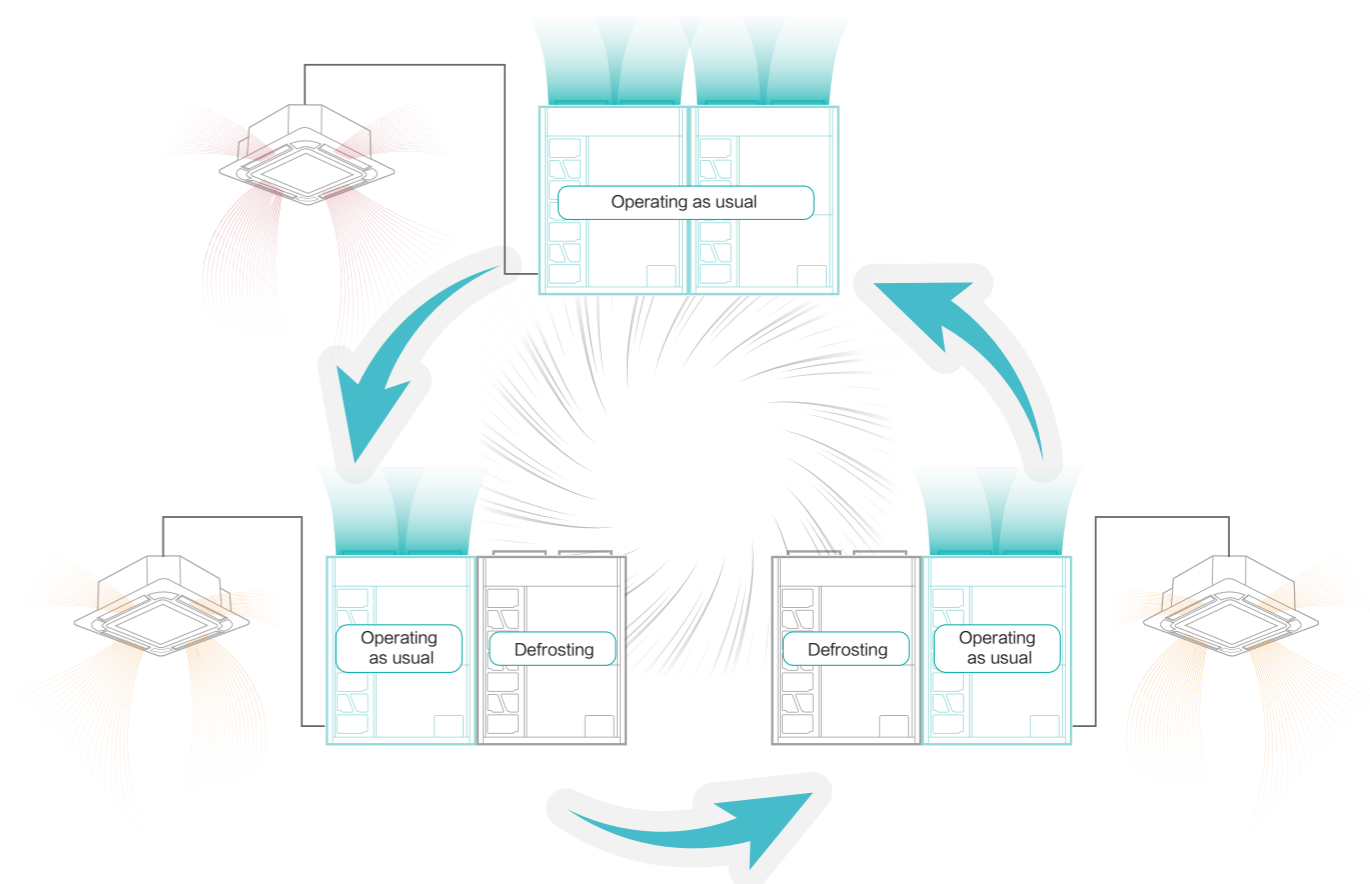
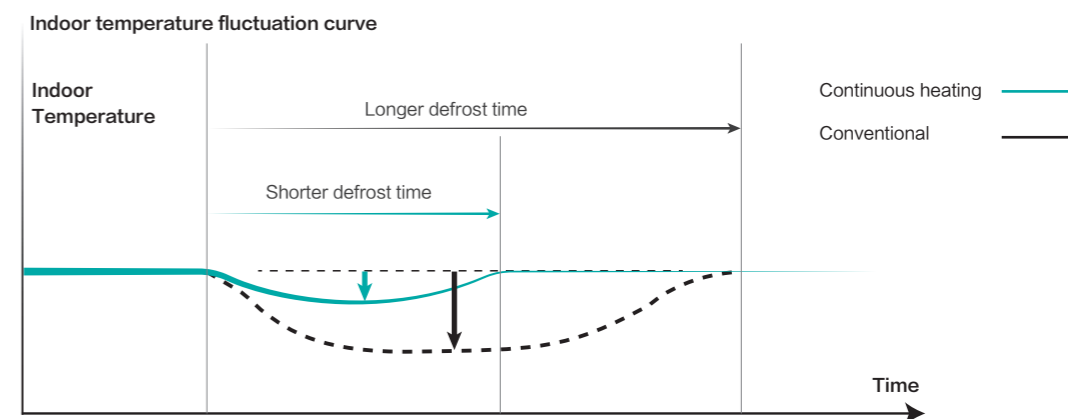

Note
Available for modules combination of S5, S heat recovery, S mavo+ series.

Bottom anti-frosting structure

To ensure effective frost removal, heat exchanger circuit is extended to the bottom to make sure melted frost from the top does not solidify as it reaches to the condensate drain and hence enhances smooth discharge. In the meantime, the heat also extends frost formation periods whereby prolongs defrost interval.

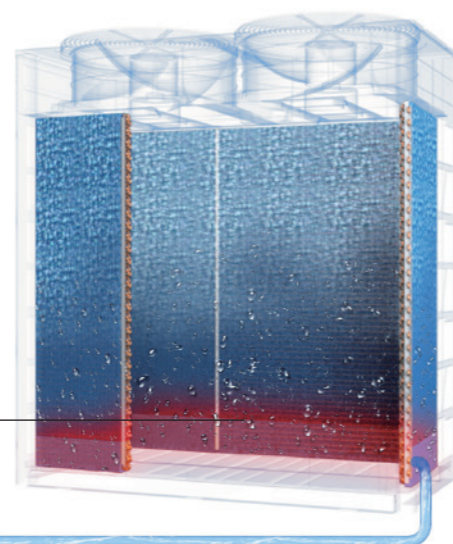

Extended heat exchange coils, keeping the bottom warm

Smooth continuous condensate drainage

Steady Air Discharge

High efficiency aerodynamic axial fan

The propeller bearing which acts as the joint connecting the propeller and motor are specially treated with anti-rain corrosion treatment and propeller made of fiber glass composite is now better corrosion resistance. Fan blades are aerodynamically designed to reduce energy wastage in converting power consumed to unnecessary noise energy, reserving the energy to improve on flowrate performance and static pressure. Integration with brushless DC fan motor further improves the efficiency and reduces noise of the propeller structure.

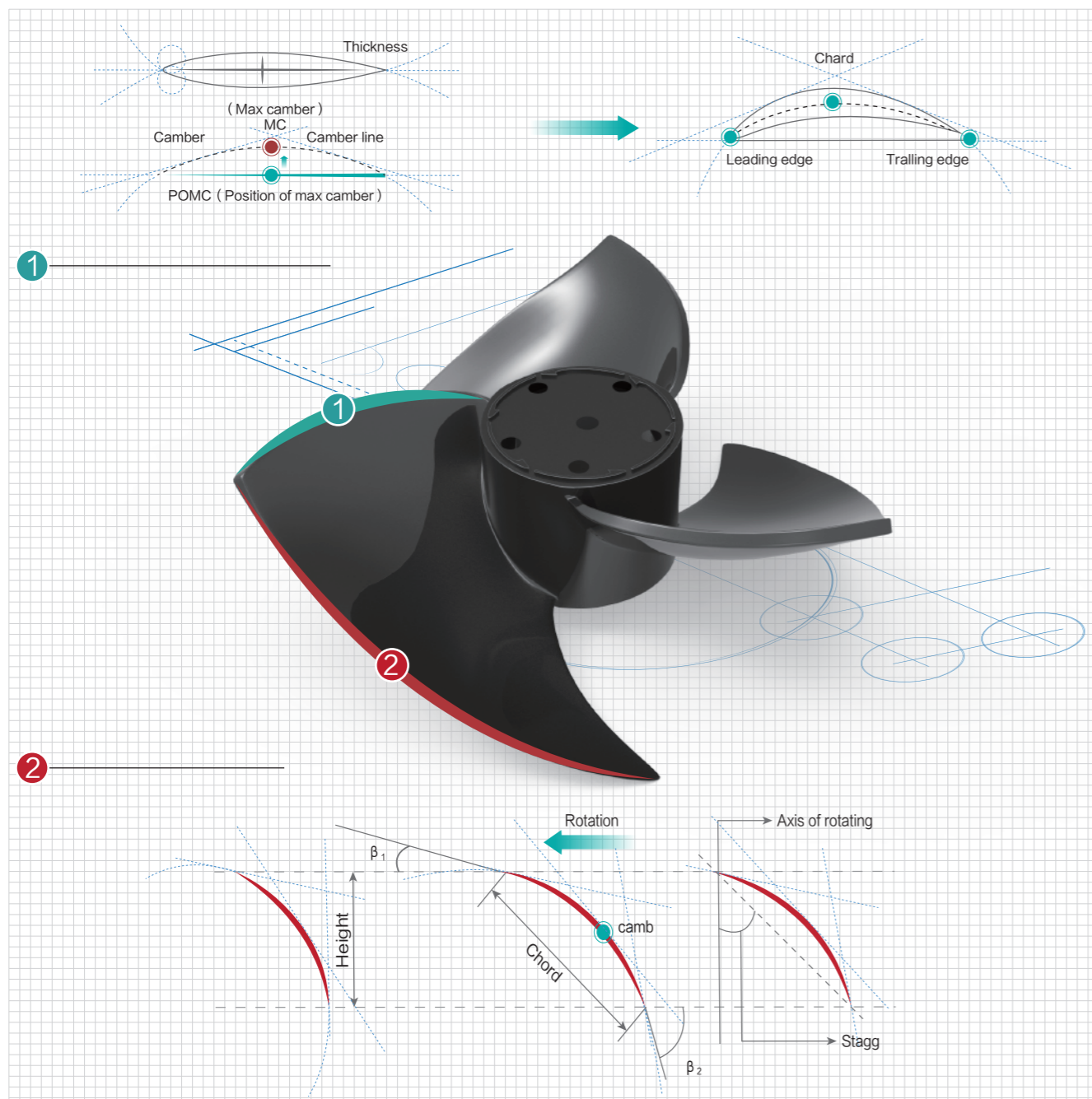

Stepless-smooth fan speed control

Inverter fan motors are now commonly used, where efficiency increase by 40%. Whereas in Hisense VRF, brushless DC fan motors are used, as it could further reduce power consumption and noise production than normal inverter motors.

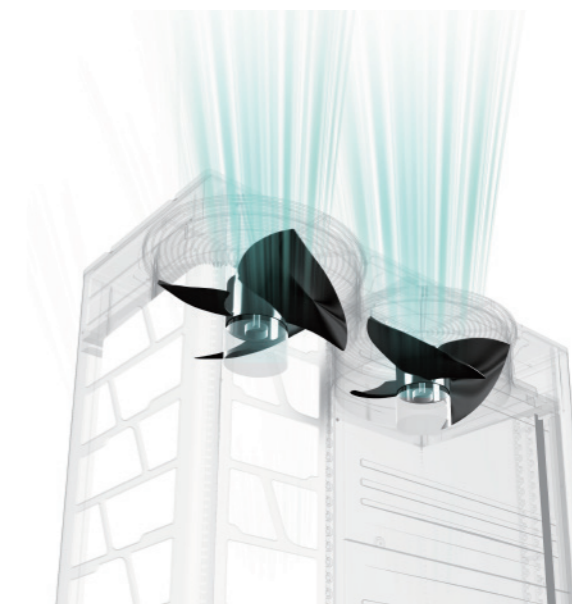

Efficient axial fan

LBC Load balancing control (LBC) technology

By identifying actual load demand in real-time, it adjusts the air volume and temperature automatically to balance the load output of different rooms. It reduces power consumption by 18% during low loads and speeds up temperature adjustments by 50% during high loads.

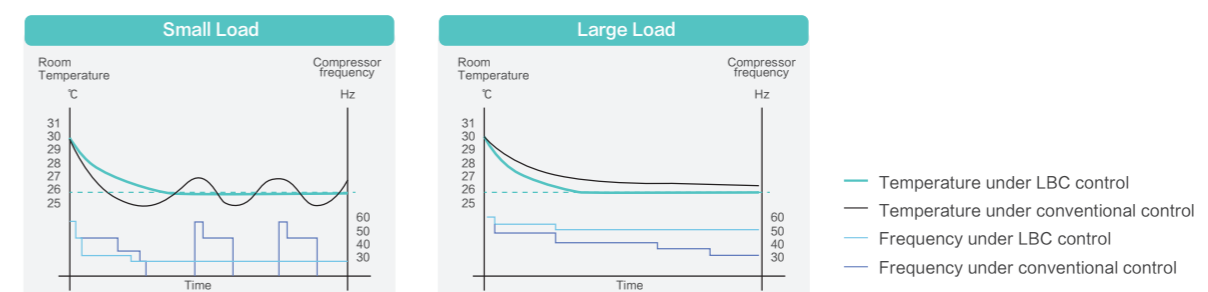
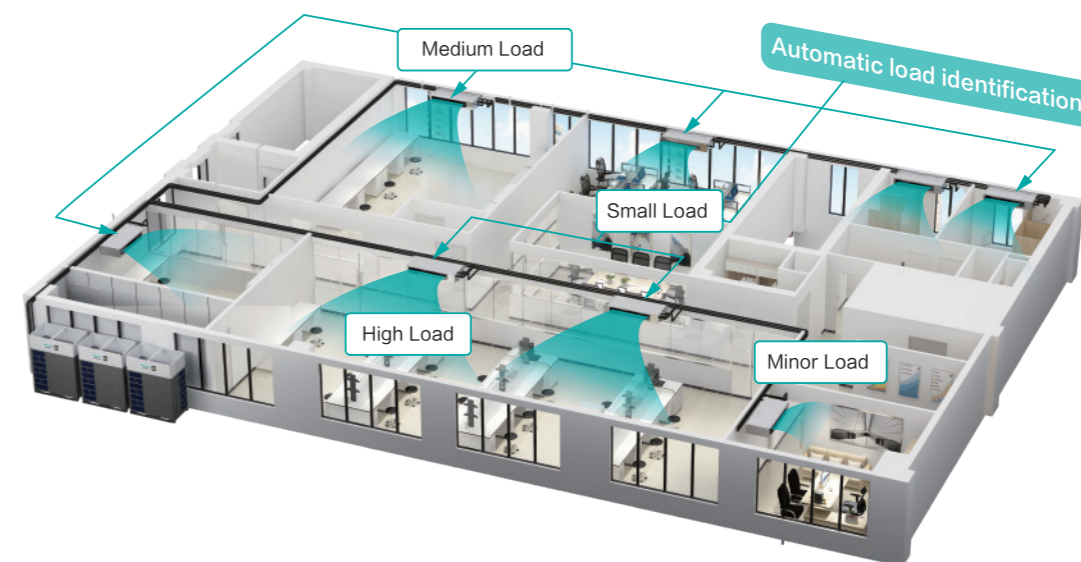

Hisense VRF

COMFORT

Smart Air Supply

Lower Noise

Clean Fresh Air

Auto Refrigerant Temperature Control (ART)

VIP Mode

AIR
CONDITIONING
SOLUTION

Smart Air Supply

Precise temperature control

There are multiple temperature sensors equipped in the system, which will be very helpful to judge the indoor load more accurately. Also the 3000-step EEV is specially adopted to ensure precise refrigerant flow adjustment according to the actual load of indoor units, achieving a more comfortable indoor environment with small temperature fluctuation.

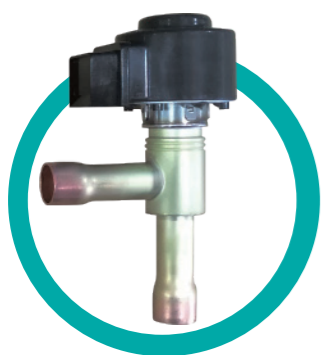

3000-step EEV

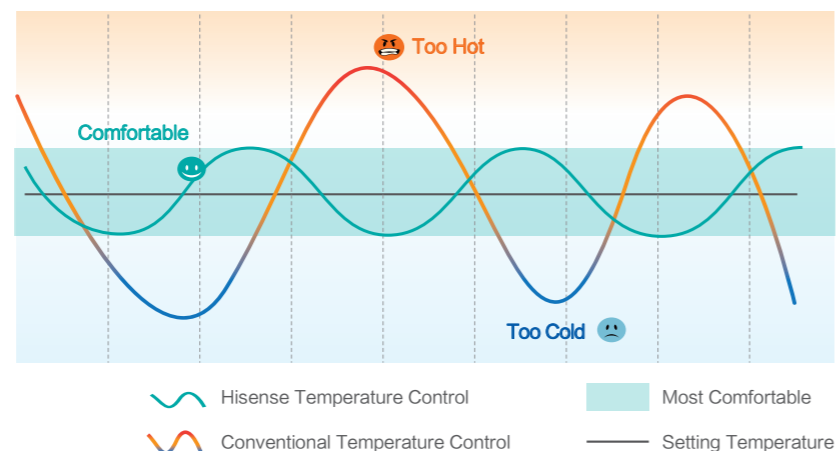

3D air-flow panel(optional)

The 3D air-flow panel with luxurious appearance is available for the low-height ceiling ducted indoor units (optional). The 3D airflow panel can offer even airflow and wide airflow coverage to keep every corners of your room cool or warm. It also has three wind setting, normal mode, 3D mode and super long distance mode, flexible for you choice.

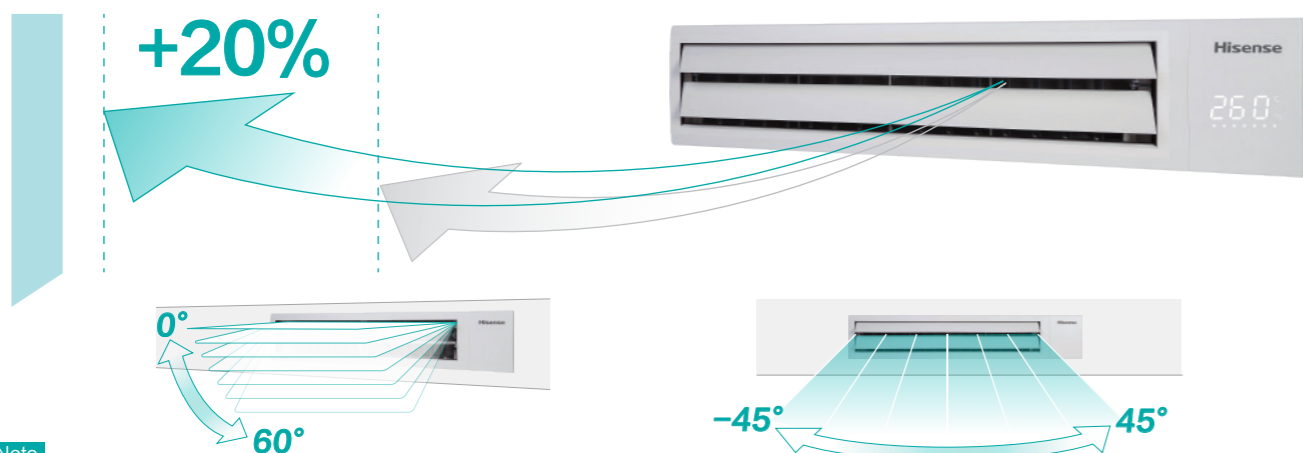

Note
It's optional for the AC/DC low height ceiling ducted unit.

Hi-motion (optional)

Hi-Motion works as an independent human sensor and can be installed separately from indoor unit. It can detect the human activities indoors to provide comfort and energy savings.

1. Automatically stops the unit when no one is in the room in order to realize energy saving.
2. Adjusting the setting temperature and air flow according to the actual human activity.

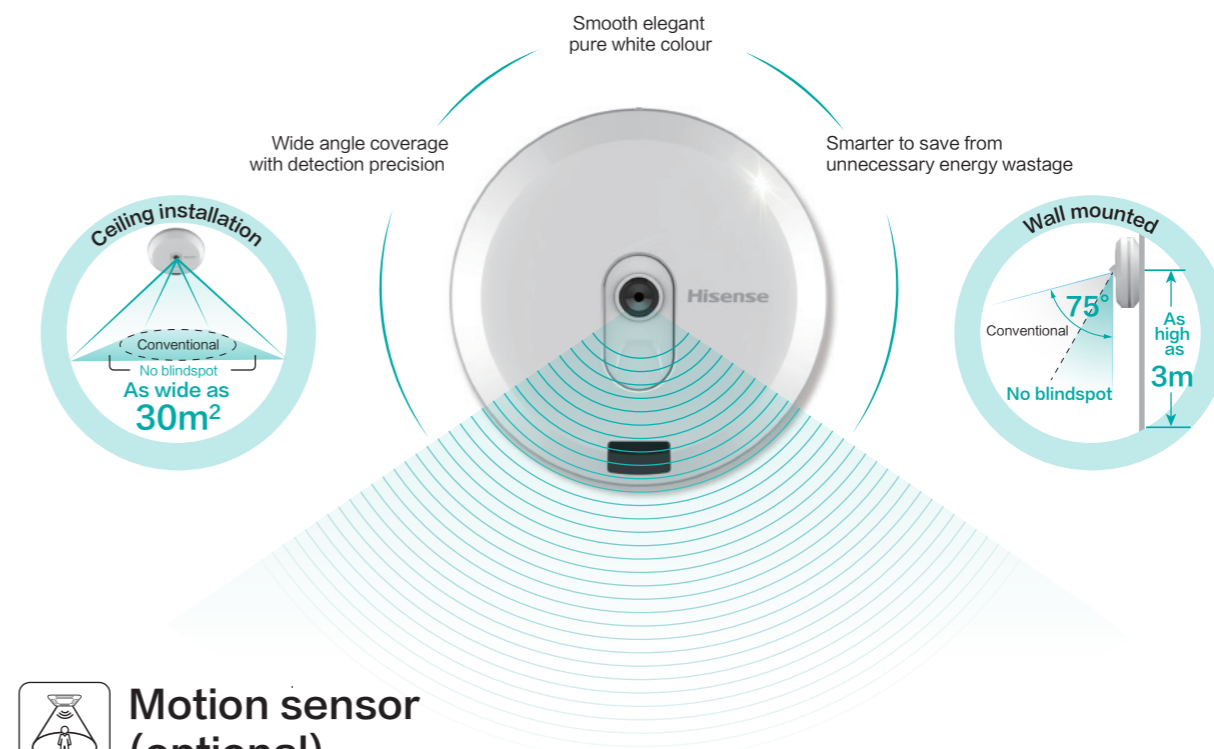

Motion sensor (optional)

Motion Sensor, assembled in the panel of 4-Way Cassette and Mini 4-Way Cassette, can provide a more comfortable environment, and achieve efficient and energy-saving operation of the unit at the same time.

1. With the sensor, indoor unit can be turned ON or OFF automatically when people enter or leave the room.
2. The sensor can automatically detect people's locations, allowing the airflow direction to be adjusted to either target directly or avoid them based on preference.
3. The setting temperature can be changed automatically by detecting the number of people changing.

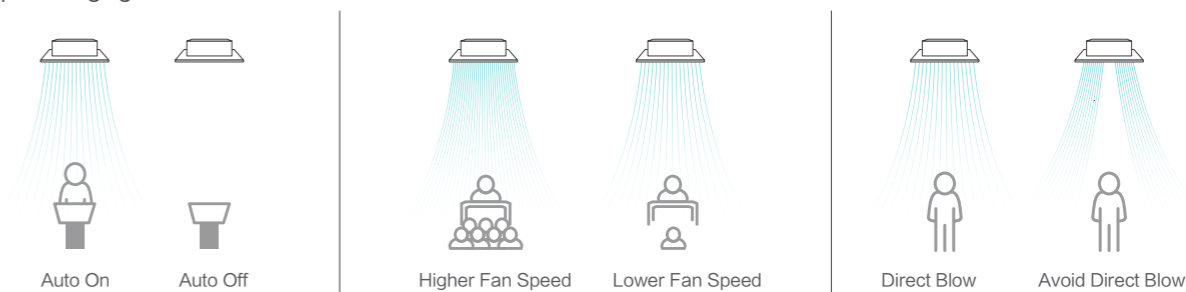

Lower Noise

Lower noise for indoor units

Hisense VRF offers indoor units with sound pressure level as low as 19dB(A), perfectly blending into library, auditorium and hospital rooms where require sound level lower than 25dB(A).

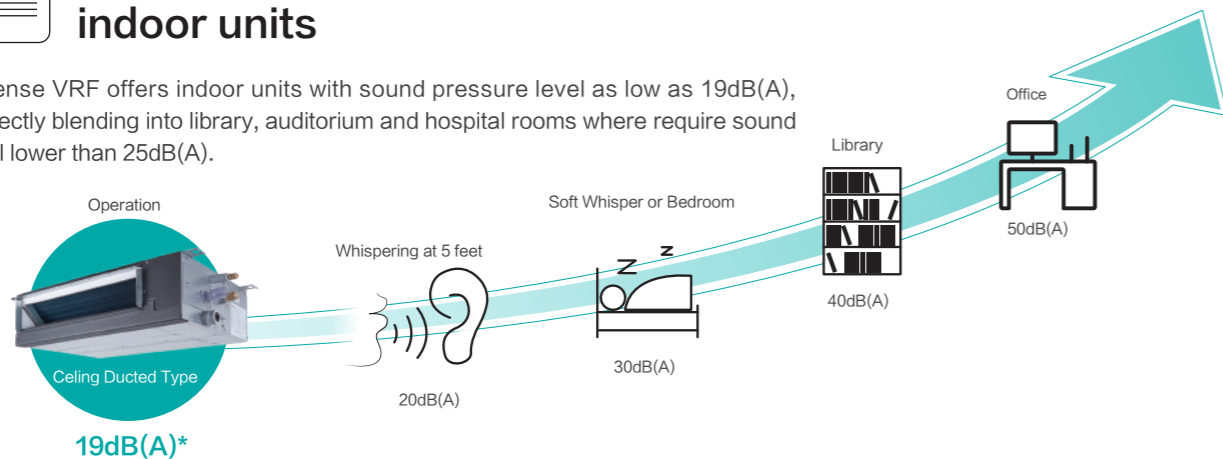

Note

*The DC ceiling ducted type (AVD-07HJDH) can achieve the 19dB(A) under the standard test condition.

Outdoor unit noise control

Auto night quiet mode

When outdoor conditions call for special low noise requirements, like in cases where outdoor units are installed in indoor equipment rooms with poor soundproof walls or continuous night operating conditions. The night mode reduces sound pressure levels upto 30% routinely with flexible time intervals to meet different customer needs.

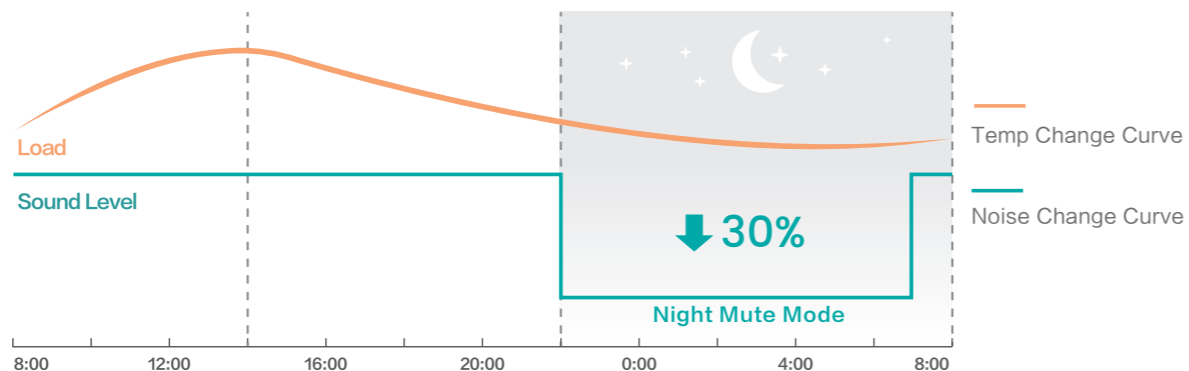

Note

*1 : The night mute mode can last for 8hrs, 9hrs or 10hrs according to the setting.

Low noise mode

Low noise mode can be set by operating the DIP in the PCB. There are multiple levels by set different frequencies of compressor and fan motor speed. What's more, the low noise mode can be achieved by external input signal. The noise can be reduced by up to 14dB(A).

90s Rapid Heating Start-up

To keep you comfortable and cozy as fast as possible, Hisense VRF starts supplying warm air so rapidly with only just 90s reaching a 100% capacity output. Besides, even in extreme weather condition like -15°C outdoor temperature, Hisense VRF performance is tested with persisting capability to supply 40°C or higher warm air within 7 minutes.

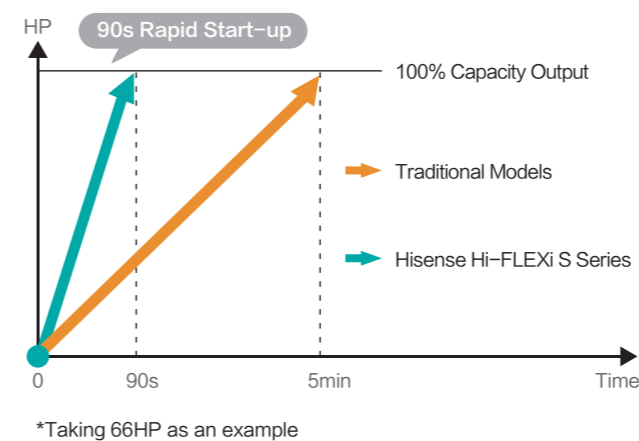

*Taking 66HP as an example



VIP Mode

Hisense VRF offers VIP mode to give priority to the specific room, keeping them comfortable and satisfied as fast as possible and 5 indoor units can be set as VIP mode at the same time. Such function is exclusively practical for hotel application, where AC unit in the presidential suite is often set to VIP mode.

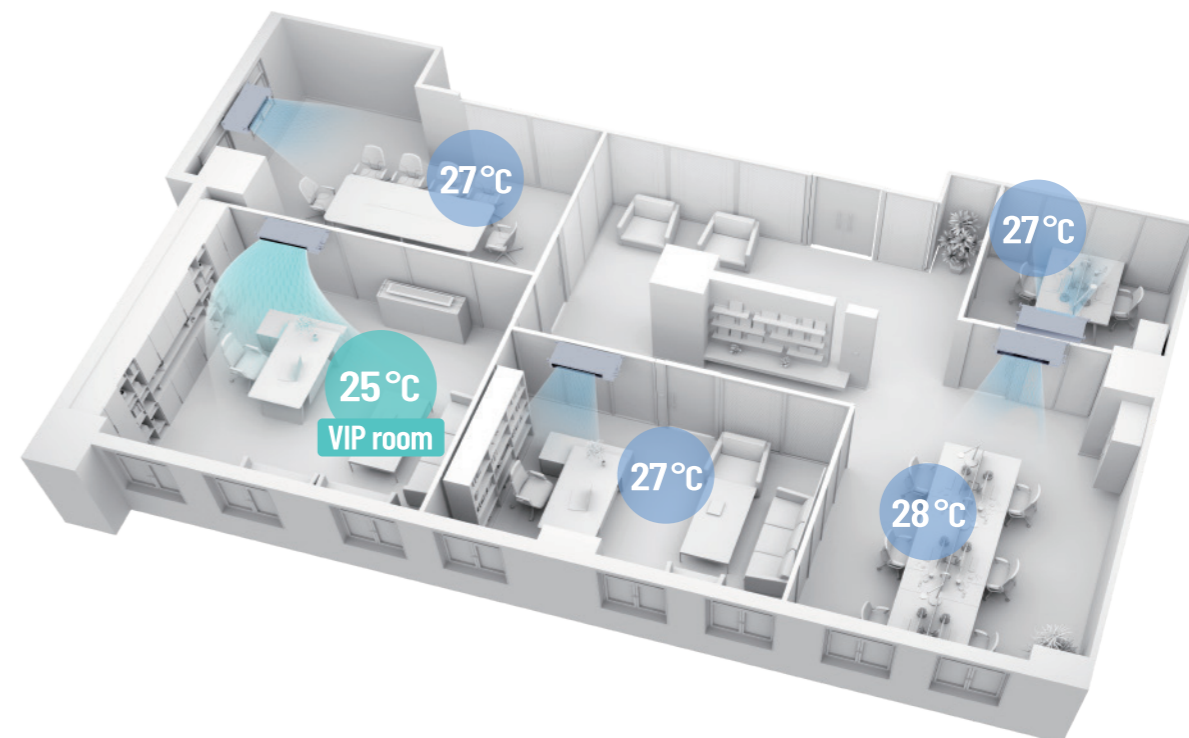

Clean Fresh Air

AirPure

Hisense VRF indoor unit equipped with AirPure kit can release lots of negative ions, about 20 million pcs/cc. These negative ions are carried throughout the room with air-conditioned air flow whereby obtaining air conditioning and air purification simultaneously. With the AirPure kit, the indoor unit has got the Tick Mark certification which is an authentication for air-conditioning sterilization products.

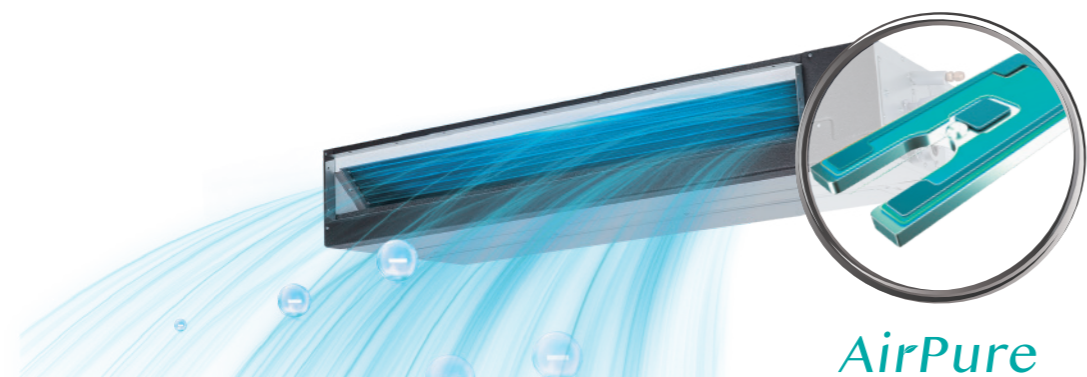
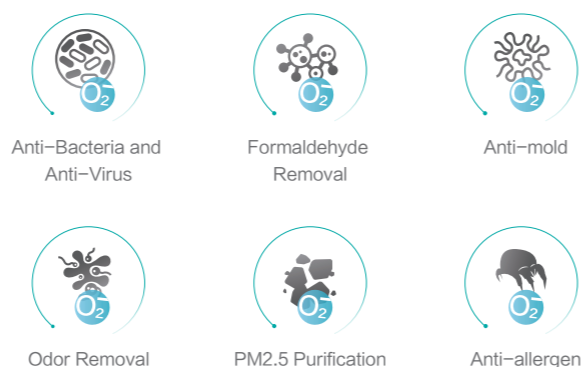

Note

4-way Cassette, Mini 4-way Cassette, Console, Ceiling Ducted can be equipped with the AirPure kit (optional).

Self-cleaning function

Featured with self-cleaning technology, the evaporator can be self-cleaned automatically, preventing the dust and potentially harmful substances from accumulating on the surface of the heat exchanger. Thus the air blown from the air conditioner is clean and healthy.



Note

The self-cleaning function is available in the wall mounted unit and DC high ESP ceiling ducted unit(AVD-07~AVD-54).

Humidity sensor (optional)

To keep up with the indoor quality requirements, Hisense VRF offers auto dehumidification function and it can be achieved by choosing a humidity sensor, and the control range is from 35% to 90%.

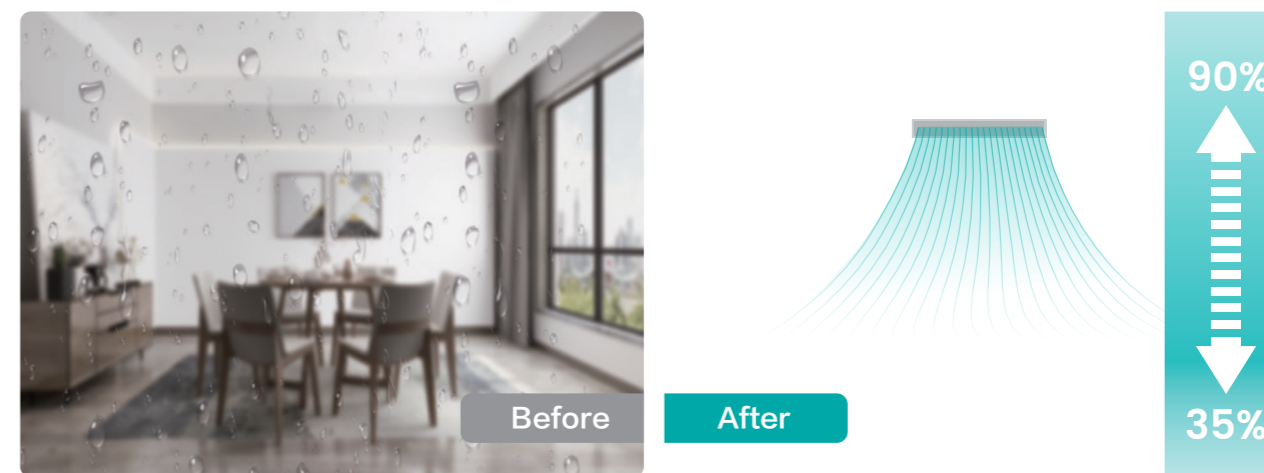
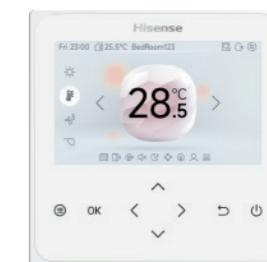

Fresh air intake

New Hisense VRF indoor units are now infused with a fresh air duct opening for 10% free fresh air introductory directly from outdoor air, creating a comfortable and health environment.

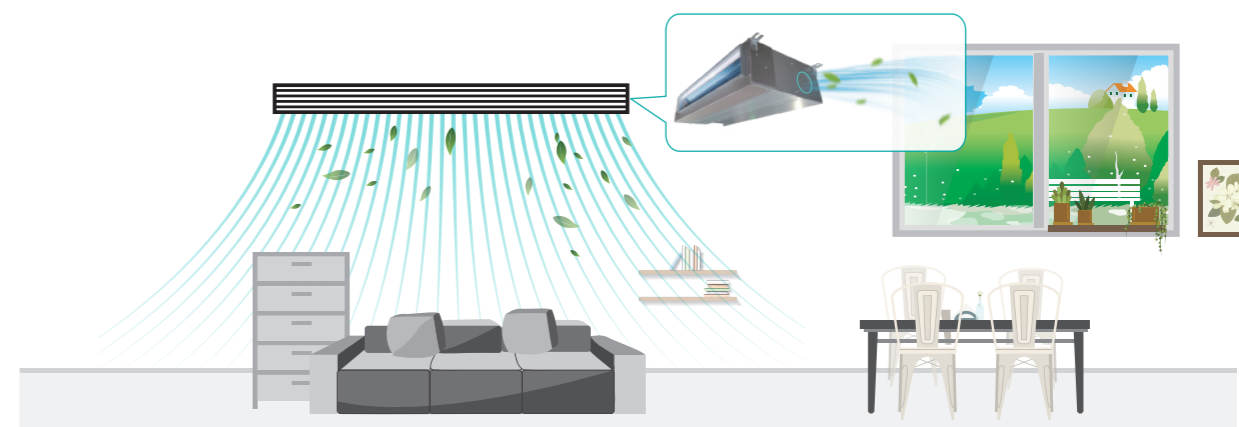

FLEXIBILITY



Design Flexibility

Installation Convenience

Service & Maintenance Simplicity

Design Flexibility

Interlocking solution using dry contact

3rd party thermostats can be used to control the air conditioner in a room by using the dry contact interface. Indoor units can be interlocked with various types of input signal such as key-card, window contact signal, smoke alarm signal and so on.

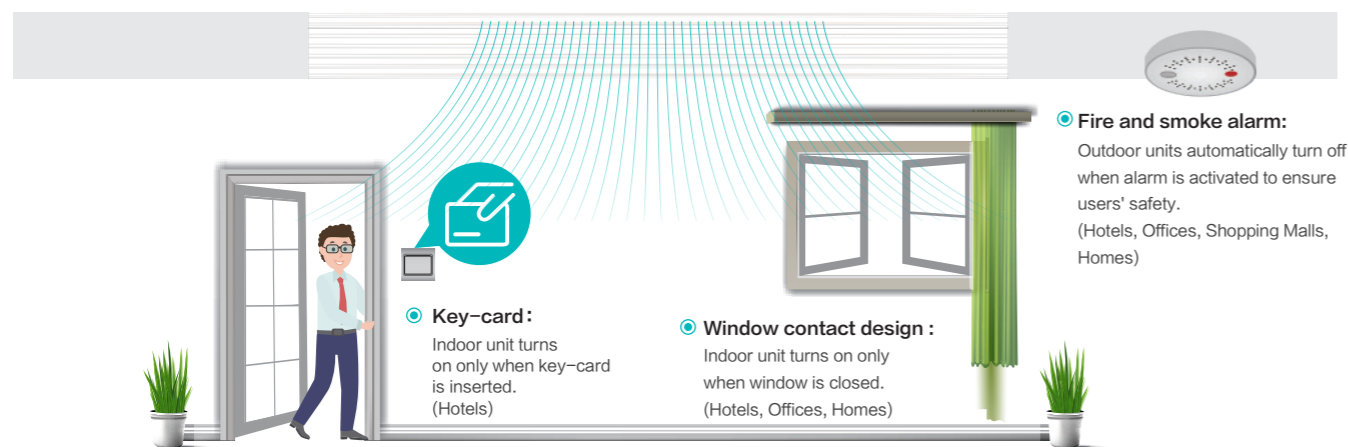

Adaptive fan static pressure technology

External static pressure is essential to determine the air discharge and duct connection distance. Hisense VRF's outdoor unit external static pressure is reachable up to 150Pa. Allowing longer ducting connection for better air discharge when are installed in the equipment platform that is not easy to exhaust.

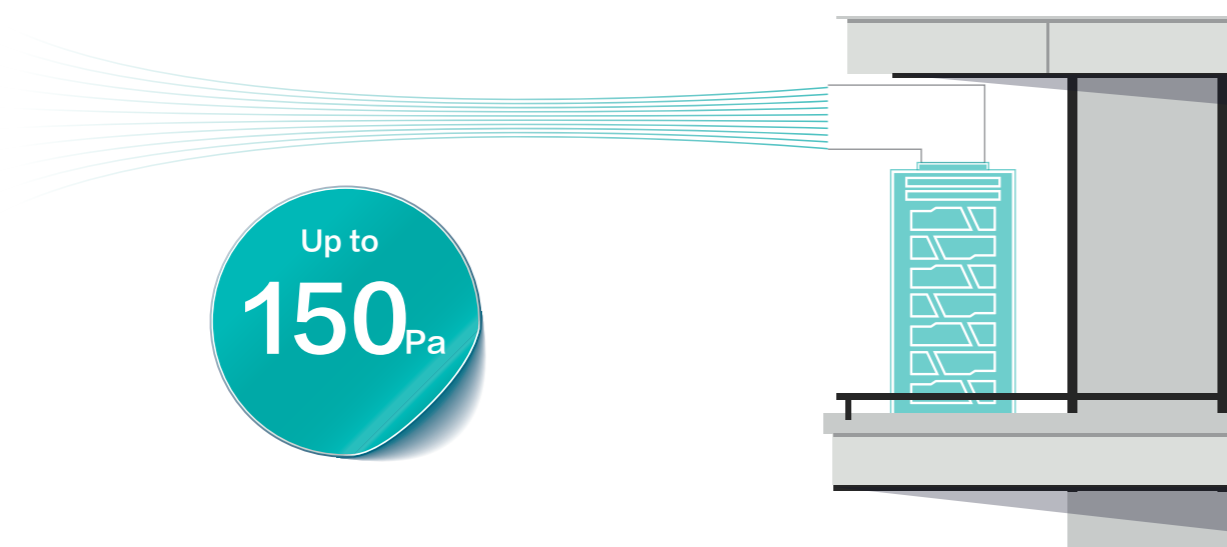

Note
The initial setting of S5 series is 110Pa, and can achieve 150Pa with a pressurization kit. For detailed information, please contact Hisense technical engineers.

Space-saving with reduced footprint

The footprint of S5 series of 8HP has been reduced by 15% compared to its predecessor with the same capacity, enabling easy transportation via elevators and effortless installation in confined spaces. With a maximum single module capacity up to 36HP, it offers a further 22% space saving compared to previous combination modules, significantly saving valuable floor space.



All in one renewable energy solution

Hisense VRF heat recovery series offers an ultimate solution to satisfy heating and cooling, domestic hot water supply, floor/wall/ceiling cooling and heating simultaneously. The heat recovery system is also compatible with any auxiliary heaters like solar, electric heater and gas boiler to supply additional energy to the system in unfavorable conditions.

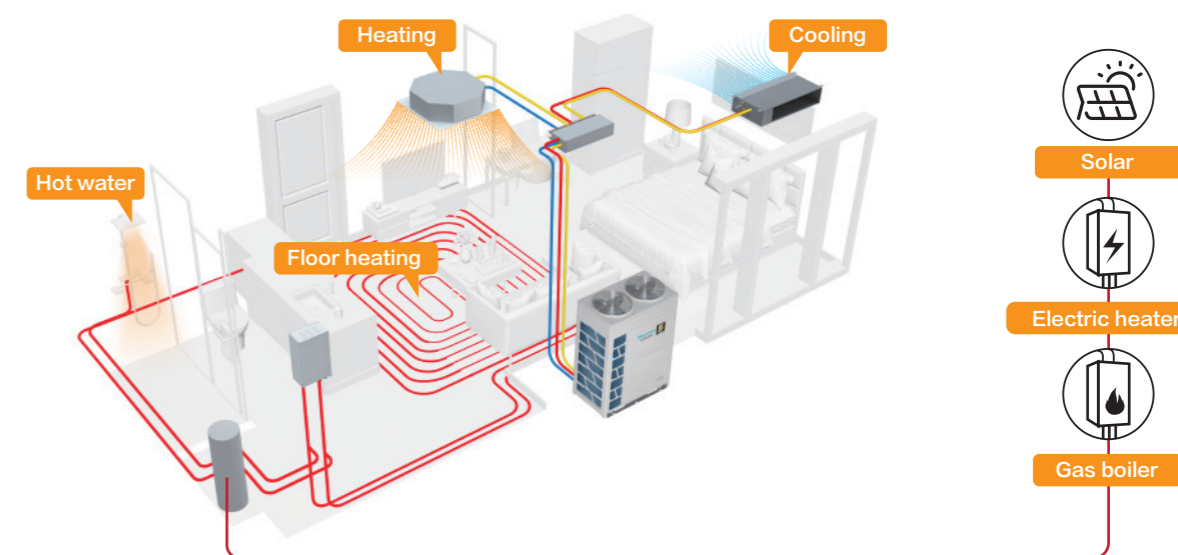

Installation Convenience

Compact and light-weight

With larger capacity per unit, Hisense VRF outdoor units are more compact in size with the largest capacity of single module, leading capacity of a single module in the market. Compact yet reduced overall weight makes transportation much convenient and even fit into elevators.



One-touch test run

Test run is an essential part of the commissioning process. To make it as simple as possible, the S5 series offers three one-touch methods for installers with just a single button press, regardless of whether indoors or outdoors.



Method 1: PCB button press



Method 2: NFC control on the APP



Method 3: Through the wired controller

- Automatically detect whether the power supply is in reverse or out of phase state.
- Automatically detect abnormal communication and wrong wiring connection.
- Automatically identify pipeline length for more optimal operation.
- Automatically confirm the normal operation of components such as compressors, fan motors, EEVs, four-way valves, etc.

Error-free communication connection

Communication line connections between outdoor unit to indoor units might be confusing when comes to long cables from the outdoors to the indoors and vice versa. It is often incorrectly connected and caused various errors affecting the end user's comfort levels. Despite of Hisense VRF's simple wiring connection ports, the outdoor unit itself could also check on the connections and display warnings when the connections are improper.

Indoor units from different systems are connected to the incorrect outdoor unit, alarm codes flashes out warning installers to make proper corrections.

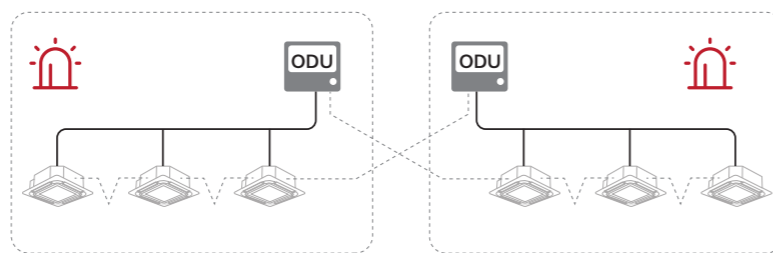

AUTO Intelligent matching IDUs

Match all kinds of hisense indoor units. If each air deflector can be controlled independently, the key will light. On the contrary, the key will dim and you can not click.

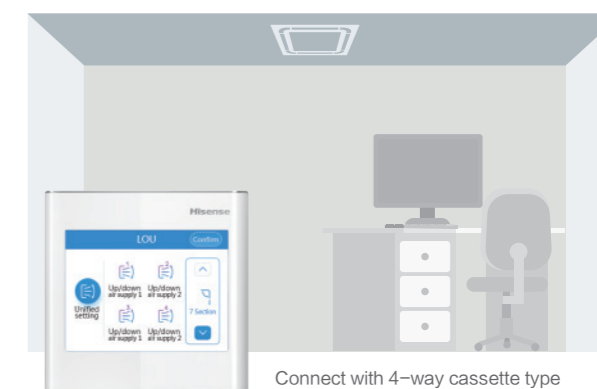
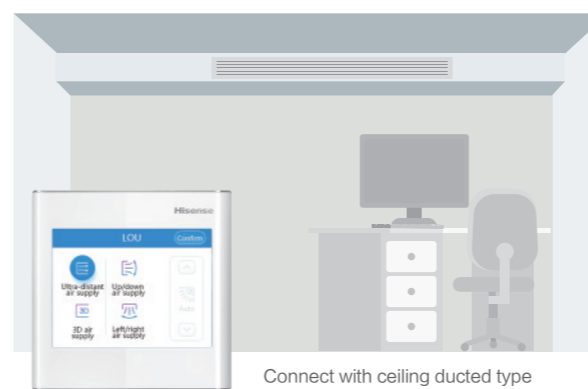

One-touch refrigerant recycle

Hisense VRF has one-touch refrigerant recycle function. Just with a press of the button on the PCB, the refrigerant can be recycled directly, it is very helpful and convenient when the indoor units or the compressor are under repair.



Scan the QR code to view the detailed introduction

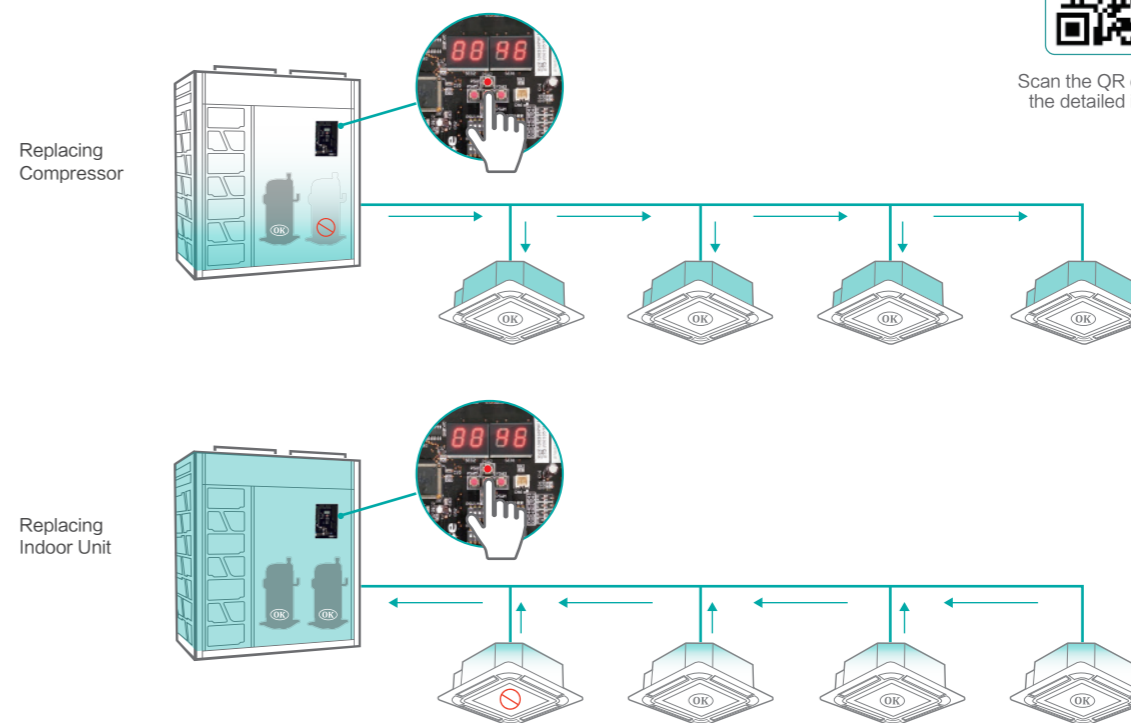

Service & Maintenance Simplicity

Automatic address distribution

The system can automatically distribute addresses for indoor units, no need to manually set the address one by one. This feature greatly simplifies the installation and commission process.

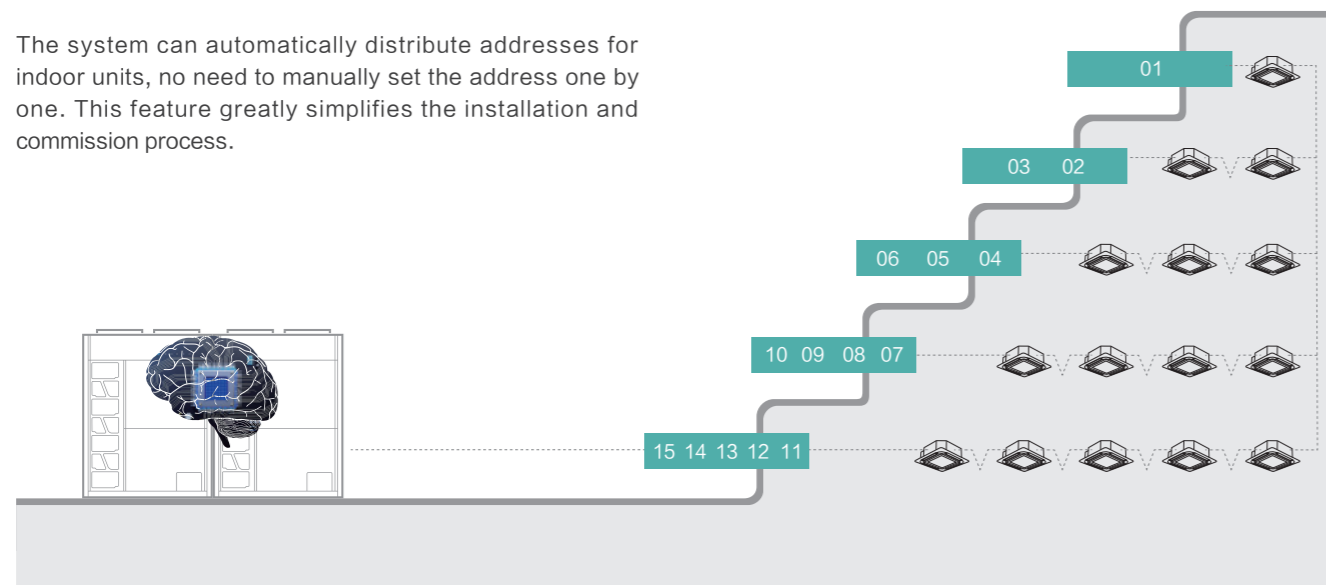

Safe and convenient system management

The new outdoor units are equipped with a service window on top of the electrical box protection panel for easy access to parameters checking and maintenance manipulation safely without exposing to high voltage segments of the electric box. With the new service windows, press switch buttons, DIP switches and the 7 segment LED operation are made safer and more convenient to operate.



Separated mechanical & electrical compartment

The outdoor unit's mechanical and electrical segments is now designed and optimized repositioned separately for a more organized maintenance. The electrical and electronics are placed on top of the compressors and accumulator to meet the practical law of center of gravity, hence minimizing toppling accidents and unnecessary vibration produced during operation. Besides, it also maximizes the heat dissipation of electrical box to keep the electrical in a stable temperature by maximizing airflow passed by.

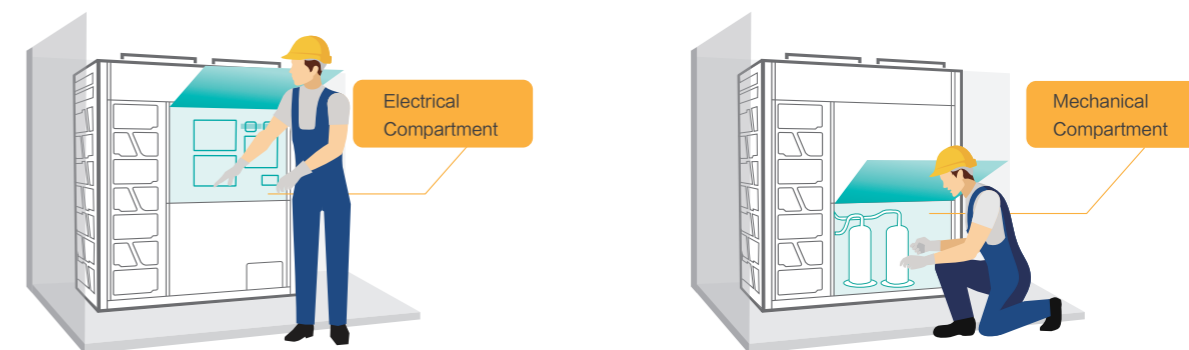

Accurate intelligent system diagnosis

Exclusive Hi-Checker is a super intelligent service tool for system diagnosis, which can provides easy access to service parameters. Detail operation status and recent error history can be checked and analyzed by using Hi-Checker.

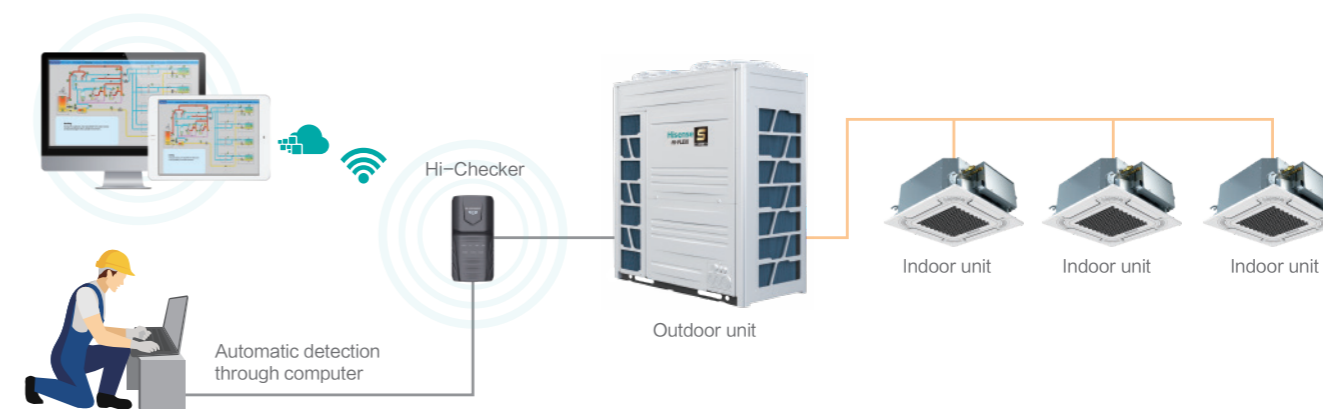

OUTDOOR UNIT

Hi-FLEXi S5 Series

Hi-FLEXi S Series Heat Recovery(Standard)

Hi-FLEXi S Series Heat Recovery(High Efficiency)

Hi-FLEXi S mavo+ Series

Hi-Smart H5 Series

Hi-Smart A Series

Hi-Smart L+ C+ Series

Hi-Smart H Series

Hi-FLEXi **S5** Series

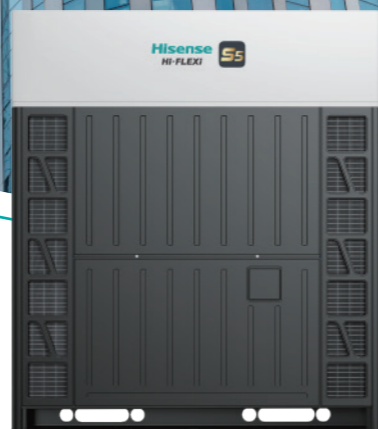

IP55 Electrical Control Box:

- Smaller size
- Fully-sealed
- PCB Micro-channel Refrigerant Cooling
- Ventilation Fans



Larger fan with higher airflow and lower noise



DC Fan Motor

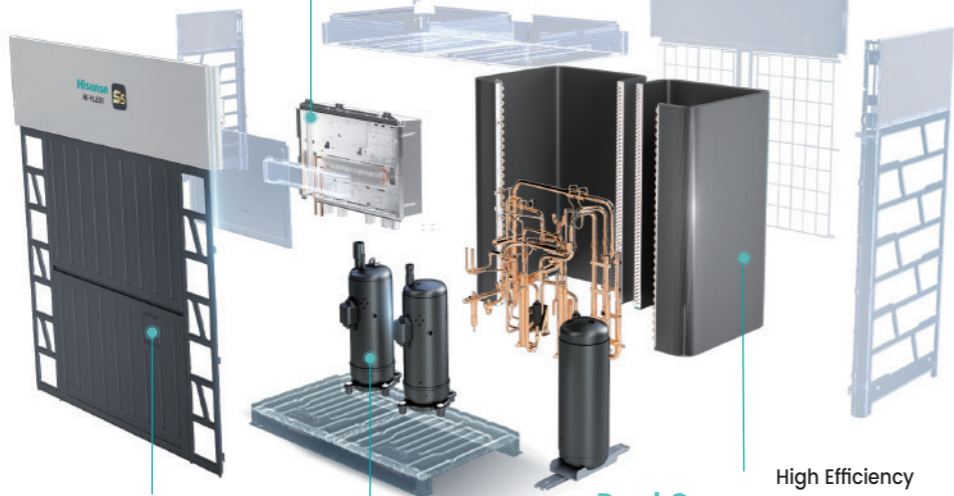

NFC Easy Access

Dual G-shape Heat Exchanger

High Efficiency

- Enhanced Vapor Injection DC Scroll Compressor
- Electromagnetic Heating Technology

Electromagnetic Heating Technology

The new generation of compressor adopts electromagnetic heating technology, which directly heat the lubricating oil inside the fixed rotor instead of traditional external electric heating belt. With this technology, power consumption can be reduced by 40% and the heating speed improved by 50%.

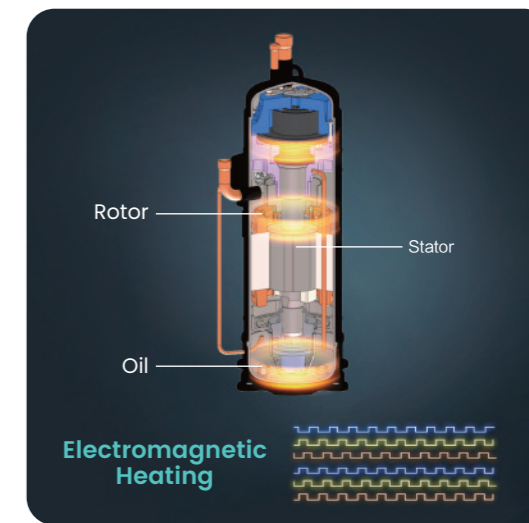
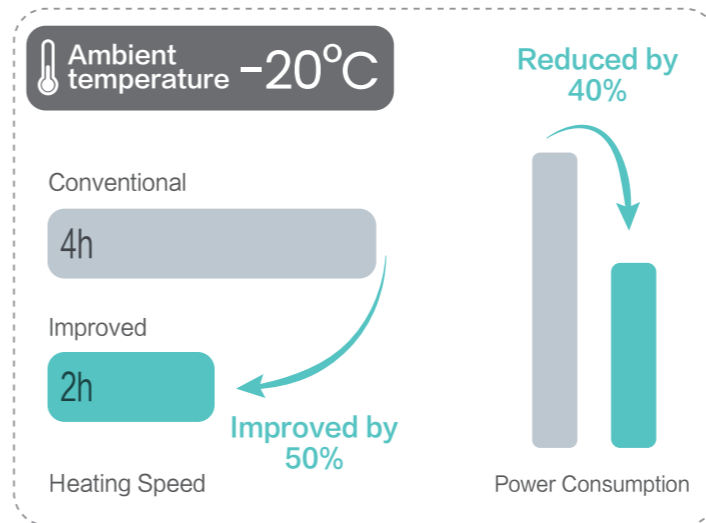

2W Standby Mode

During long-term standby periods such as holiday or transition season, traditional devices often result in unnecessary energy waste. Hisense S5 Series tackles this issue with its innovative 2W standby mode and circuit design, which not only saves on your electricity bills but also contributes to environmental protection, making the S5 Series a smart choice for both your wallet and the planet.



Aerodynamic Axial Fan

New Enlarged Fan Design

The newly designed $\Phi 750\text{mm}$ large-diameter axial fan can reduce the turbulence around the fan, leading to a 5% increase in static pressure efficiency, a 3dB(A) reduction in noise levels, and a 21% decrease in power consumption for the same airflow volume.

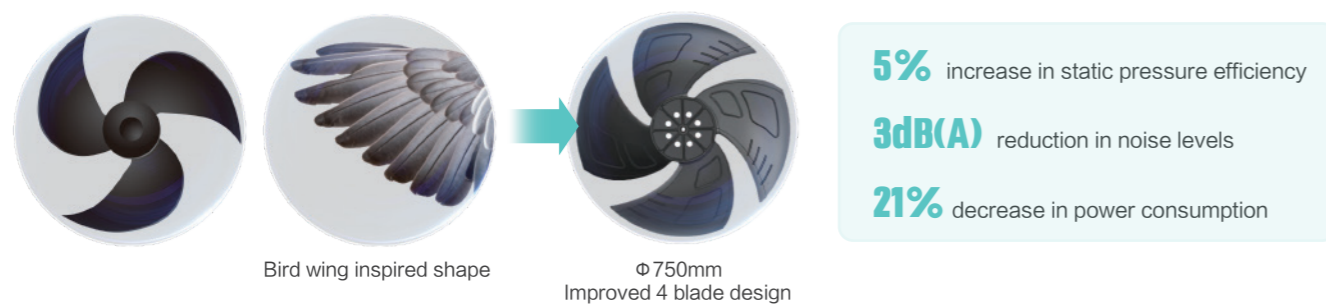

Anti-headwind Function

The ODU fans might be blown to the opposite direction when caught in a heavy wind. If the unit suddenly turns on, the fan will rapidly switch from spinning backward to forward, which may damage the fan blades. To prevent this, the S5 series is designed to first stabilize the fan before it starts up and rotate in the correct direction, protecting the fan blades from damage.



Dust-removal Function

In case of heavy sandstorm or long-term use, the heat exchanger can get clogged by dirt, resulting in a decrease in heat transfer effect and an increase in energy consumption. Hisense innovative "Dust Removal" function solves this problem. The fans automatically blow in reverse for 1 to 5 minutes to remove dust from heat exchanger when turned on, off, or both, thereby enhancing product performance and reducing energy use.

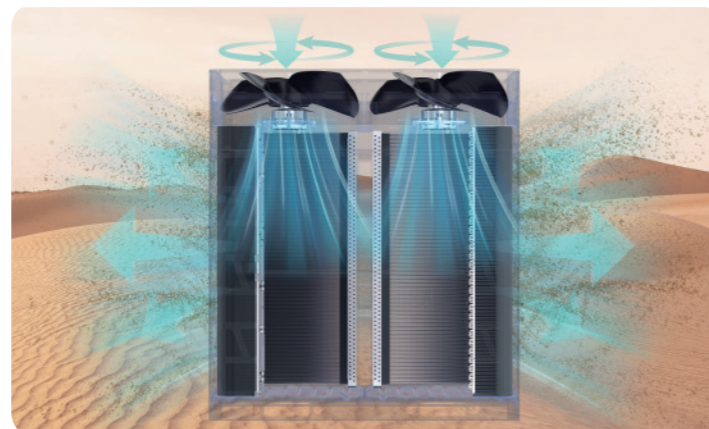

IP55 Electrical Control Box

Smaller Size

By adopting miniaturized components and dual-sided layout, the size of electrical box is reduced by 18% to 54% compared to the previous types, making installation more convenient. This design also greatly widens the air duct space, reduces wind resistance, thus improving air circulation rate and increasing heat exchange by 6%.



Fully-sealed

The IP55 electric control box features four layers of sealing to prevent rain, snow, sand, dust, insects and fire from entering. It ensures the durability of electrical components and reliability of unit operation.



Micro-channel Refrigerant Cooling PCB

The box is cooled by micro-channel refrigerant cooling technology, with thermal resistance reduced by 20% compared to previous copper-aluminum refrigerant pipes. This innovation lowers the internal temperature of the box by 5°C to 10°C compared to traditional air-cooling methods.

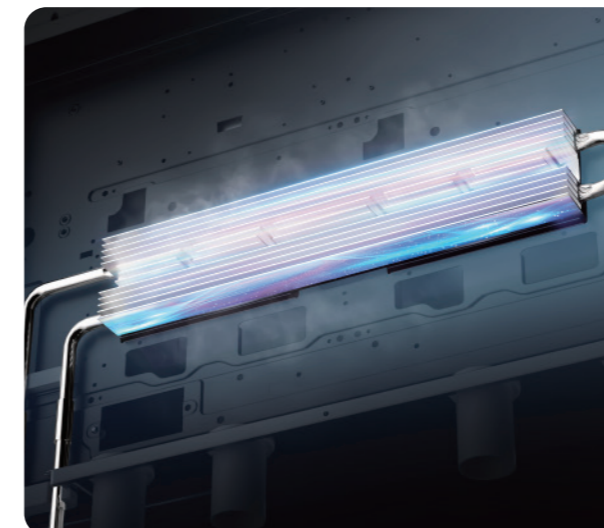

Ventilation Fans

Additionally, the addition of ventilation fans at the back of the box further aids in efficient heat dissipation and temperature reduction by accelerating internal air flow.

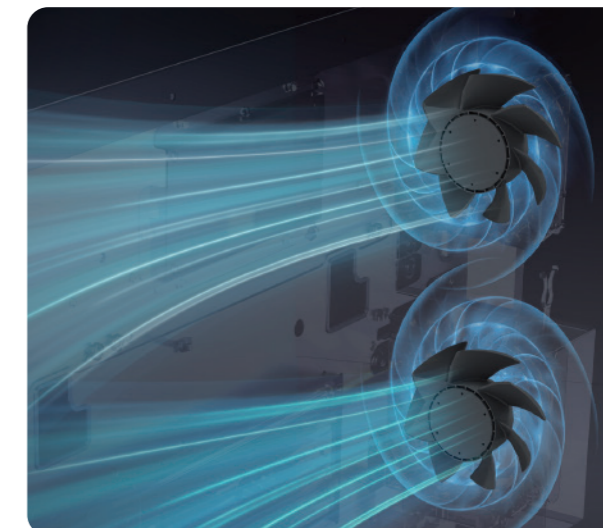

Resistant to Harsh Environments

The Hi-FLEXi S5 series has been rigorously tested in a variety of harsh environments, including extreme heat and humidity, freezing rain, heavy snowfall, severe typhoons, and even strong earthquakes, etc. These comprehensive tests have consistently proven its exceptional quality and reliable performance, even under the most challenging conditions.

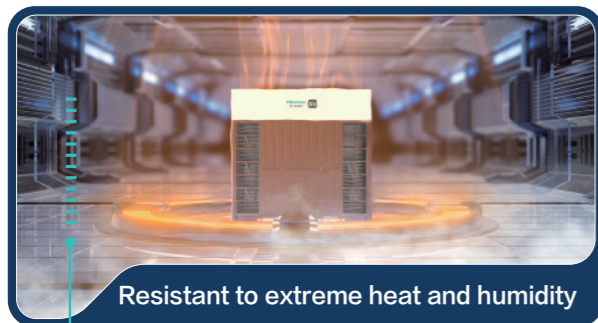

Resistant to extreme heat and humidity

Test Condition: Tested for 24 hours at 60°C with 95% humidity



Resistant to freezing rain

Test Condition: Sprayed with a water flow rate of (12.5 ± 0.625) L/min until ice formation reaches 6mm, and then operated continuously at -7°C for over 3 hours



Resistant to severe typhoon

Test Condition: Tested for 10 minutes at a simulated hurricane wind speed of 61.2m/s (Category 4)

*Note: According to Saffir-Simpson Hurricane Wind Scale.



Resistant to M9 earthquake

Test Condition: Continuous testing under simulated magnitude 8 to 9 earthquake without any additional protection structure

Automatic Refrigerant Management

Refrigerant Self-charging

The S5 series maintains optimal refrigerant level through high-precision automatic refrigerant charging technology, which promotes stable and reliable performance while maximizing energy efficiency. Besides, the process has been greatly simplified compared to conventional manual refrigerant charging, making installation and maintenance easier and more efficient.

Refrigerant Detection

Conduct one-touch detection to identify the refrigerant leakage quickly in case of poor cooling and heating performance, so as to improve the maintenance convenience and efficiency.

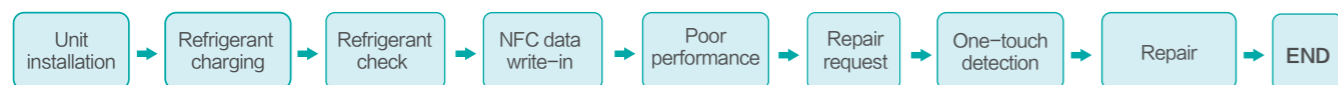

Load Balancing Control (LBC) Technology

LBC technology identifies the current load demand of each indoor unit and calculates the optimal air volume and temperature settings based on the unit's capacity, so as to balance the load output of each room. Compared to traditional refrigerant flow control methods, LBC technology increases balancing capacity by 30% and enhances energy efficiency by 18%.

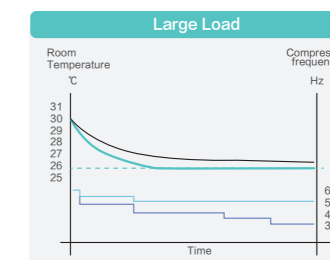
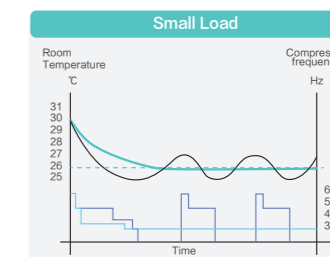
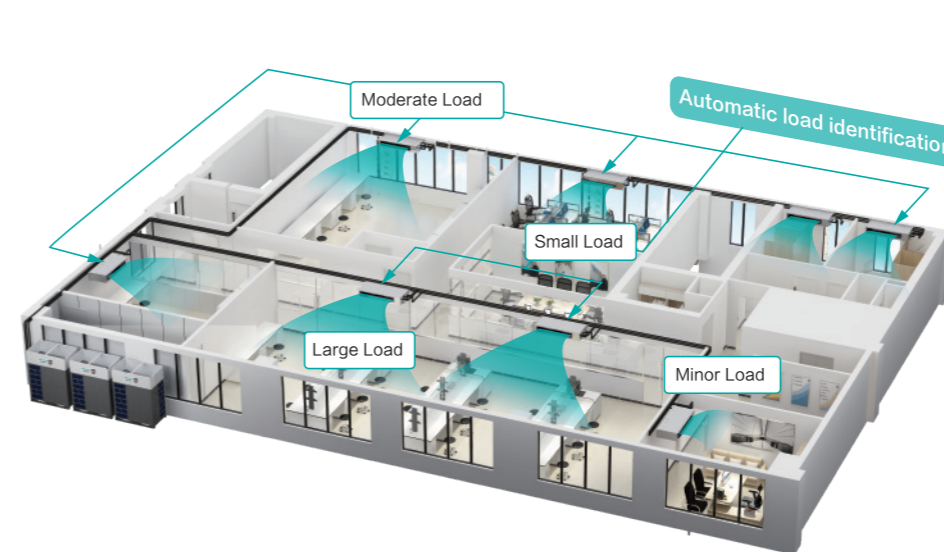

— Temperature under LBC control
 — Frequency under LBC control
 — Temperature under conventional control
 — Frequency under conventional control

Flexible Installation with Long Piping

The S5 unit has been optimized for piping, with a maximum total piping length of 1100m and a maximum single pipe length of 220m (equivalent length 260m). Additionally, the maximum connection ratio has also been increased to 200%* to greatly simplify project design.

Total piping length: **1100m**

① Maximum actual length of a single pipe: **220m** (equivalent length **260m***)

② Maximum length from the first branch pipe to the farthest indoor unit: **90m**

③ Maximum height difference between indoor and outdoor units: **110m***

④ Maximum height difference between indoor units: **40m***

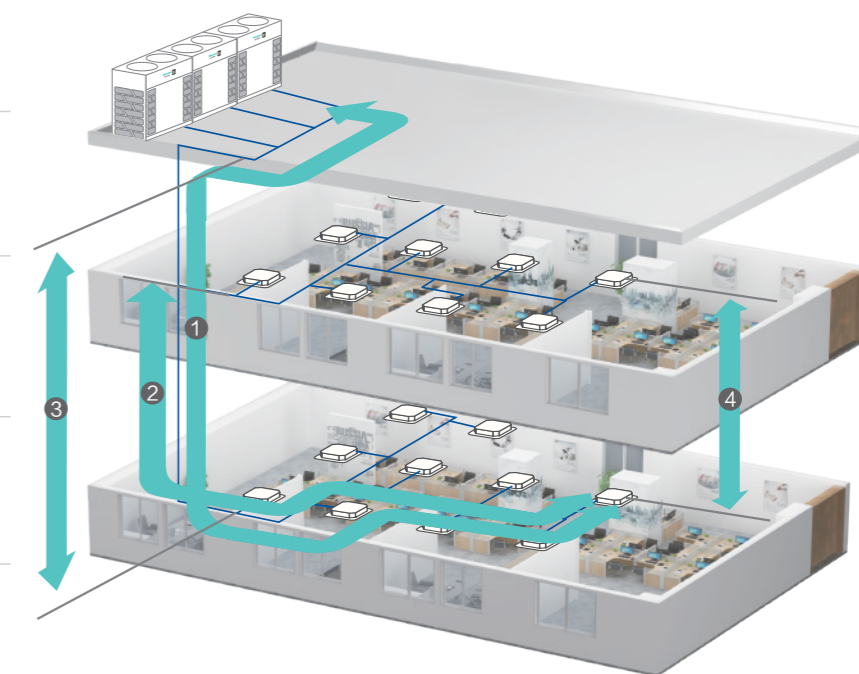

*Note: For detailed information, please contact Hisense technical engineer.

Hi-FLEXi S5 Series



HP		8HP	10HP	12HP	14HP	16HP	
Model		AVWT-76HKF5S	AVWT-96HKF5S	AVWT-114HKF5S	AVWT-136HKF5S	AVWT-154HKF5S	
		AVWT-76HKF5S	AVWT-96HKF5S	AVWT-114HKF5S	AVWT-136HKF5S	AVWT-154HKF5S	
Modules		/	/	/	/	/	
		/	/	/	/	/	
		/	/	/	/	/	
		/	/	/	/	/	
Power Supply		380-415V 3~ 50Hz/60Hz					
Cooling	Capacity*1	kW	22.4	28.0	33.5	40.0	45.0
		kBtu/h	76.4	95.5	114.3	136.5	153.5
	Power Input	kW	5.91	7.80	9.57	12.50	15.05
	EER	kW/kW	3.79	3.59	3.50	3.20	2.99
	SEER	kW/kW	7.55	7.42	7.31	7.30	7.16
Heating	Capacity (Max/Nom)*1	kW	25/22.4	31.5/28.0	37.5/33.5	45/40	50/45
		kBtu/h	85.3/76.4	107.4/95.5	127.9/114.3	153.5/136.5	170.6/153.5
	Power Input (Max/Nom)	kW	5.68/4.8	7.22/6.1	9.08/7.19	11.6/9.66	13.97/11.19
	COP (Max/Nom)	kW/kW	4.4/4.67	4.36/4.59	4.13/4.66	3.88/4.14	3.58/4.02
	SCOP	kW/kW	4.46	4.35	4.60	4.60	4.49
Ventilation	Air Flow Rate	m³/min	225	225	275	275	292
	Fan Quantity	pcs	1	1	1	1	1
	Static Pressure	Pa	110	110	110	110	110
Sound Pressure Level*2	Normal Mode	dB(A)	59	59	61	61	63
	Silent Mode	dB(A)	40	40	40	40	40
Compressor	Type	—	Enhanced Vapor Injection Scroll Compressor				
	Quantity	pcs	1	1	1	1	1
Refrigerant	Type	—	R410A				
	Pre-charged Amount	kg	6.6	6.6	7.6	7.6	7.6
Weight	Net Weight	kg	222	222	245	245	245
	Gross Weight	kg	249	249	269	269	269
Dimensions	External (H × W × D)	mm	1800x800x825			1800x940x825	
	Packing (H × W × D)	mm	1960x860x885			1960x1000x885	
Cabinet Color		—	Gray + White				
Ref. Piping	Gas Pipe	mm	φ19.05	φ22.20	φ25.40	φ25.40	φ28.60
		inch	3/4	7/8	1	1	1-1/8
	Liquid Pipe	mm	φ9.53	φ9.53	φ12.70	φ12.70	φ12.70
		inch	3/8	3/8	1/2	1/2	1/2
Connectable Indoor Units	Quantity	pcs	18	20	24	28	32
	Connection Ratio*3	—	30-200%				
Piping Design	Max. Piping Length (Actual)	m	220	220	220	220	220
	Max. Piping Length (Equivalent)	m	260	260	260	260	260
	Height Difference between ODU and IDU	m	110	110	110	110	110
	Height Difference between IDUs	m	40	40	40	40	40
Operation Range	Cooling	℃	-15℃ DB ~55℃ DB	-15℃ DB ~55℃ DB	-15℃ DB ~55℃ DB	-15℃ DB ~55℃ DB	-15℃ DB ~55℃ DB
	Heating	℃	-30℃ WB ~30℃ DB	-30℃ WB ~30℃ DB	-30℃ WB ~30℃ DB	-30℃ WB ~30℃ DB	-30℃ WB ~30℃ DB

Notes:

- Rated cooling capacity and rated heating capacity are tested in the following conditions:
Cooling Conditions: indoor air inlet temperature: 27℃ DB 19℃ WB, outdoor air inlet temperature: 35℃ DB, pipe length: 7.5m, pipe height difference: 0m.
Heating Conditions: indoor air inlet temperature: 20℃ DB, outdoor air inlet temperature: 7℃ DB 6℃ WB, pipe Length: 7.5m, pipe height difference: 0m.
- The above noise values are measured in the anechoic chamber without reflected echo, therefore the impact of the reflected echo must be included at the scene.
Measurement point: 1m from the service cover surface and 1.5m from the floor level.
- When the connection ratio is lower than 50% or higher than 130%, please consult our local technical engineers.

Hi-FLEXi S5 Series



HP		18HP	20HP	22HP	24HP	26HP	
Model		AVWT-170HKF5S	AVWT-190HKF5S	AVWT-212HKF5S	AVWT-232HKF5S	AVWT-250HKF5S	
		AVWT-170HKF5S	AVWT-190HKF5S	AVWT-212HKF5S	AVWT-232HKF5S	AVWT-250HKF5S	
Modules		/	/	/	/	/	
		/	/	/	/	/	
		/	/	/	/	/	
		/	/	/	/	/	
Power Supply		380-415V 3~ 50Hz/60Hz					
Cooling	Capacity*1	kW	50.4	56.0	61.5	68.0	73.5
		kBtu/h	171.9	191.0	209.8	232.0	250.7
	Power Input	kW	14.20	16.37	19.46	22.74	25.09
	EER	kW/kW	3.55	3.42	3.16	2.99	2.93
	SEER	kW/kW	7.10	6.90	6.80	6.40	5.80
Heating	Capacity (Max/Nom)*1	kW	56/50.4	63/56	69.0/61.5	75.0/68.0	82.5/73.5
		kBtu/h	191/171.9	214.9/191	235.4/209.8	255.9/232	281.4/250.7
	Power Input (Max/Nom)	kW	14.81/11.08	15.63/12.1	18.06/13.52	20.16/15.18	21.32/15.94
	COP (Max/Nom)	kW/kW	3.78/4.55	4.03/4.63	3.82/4.55	3.72/4.48	3.87/4.61
	SCOP	kW/kW	4.78	5.01	4.86	4.84	4.27
Ventilation	Air Flow Rate	m³/min	258	317	317	317	400
	Fan Quantity	pcs	1	2	2	2	2
	Static Pressure	Pa	110	110	110	110	110
Sound Pressure Level*2	Normal Mode	dB(A)	64	65	66	66	66
	Silent Mode	dB(A)	40	40	40	40	40
Compressor	Type	—	Enhanced Vapor Injection Scroll Compressor				
	Quantity	pcs	1	2	2	2	2
Refrigerant	Type	—	R410A				
	Pre-charged Amount	kg	9.4	12.6	12.6	13.1	11.5
Weight	Net Weight	kg	267	368	368	368	406
	Gross Weight	kg	289	399	399	399	430
Dimensions	External (H × W × D)	mm	1800x940x825	1800x1390x825			1800x1600x825
	Packing (H × W × D)	mm	1960x1000x885	1960x1450x885			1960x1660x885
Cabinet Color		—	Gray + White				
Ref. Piping	Gas Pipe	mm	φ28.60	φ28.60	φ28.60	φ28.60	φ31.75
		inch	1-1/8	1-1/8	1-1/8	1-1/8	1-1/4
	Liquid Pipe	mm	φ15.88	φ15.88	φ15.88	φ15.88	φ19.05
		inch	5/8	5/8	5/8	5/8	3/4
Connectable Indoor Units	Quantity	pcs	36	40	44	48	52
	Connection Ratio*3	—	30-200%				
Piping Design	Max. Piping Length (Actual)	m	220	220	220	220	220
	Max. Piping Length (Equivalent)	m	260	260	260	260	260
	Height Difference between ODU and IDU	m	110	110	110	110	110
	Height Difference between IDUs	m	40	40	40	40	40
Operation Range	Cooling	℃	-15℃ DB ~55℃ DB	-15℃ DB ~55℃ DB	-15℃ DB ~55℃ DB	-15℃ DB ~55℃ DB	-15℃ DB ~55℃ DB
	Heating	℃	-30℃ WB ~30℃ DB	-30℃ WB ~30℃ DB	-30℃ WB ~30℃ DB	-30℃ WB ~30℃ DB	-30℃ WB ~30℃ DB

Notes:

- Rated cooling capacity and rated heating capacity are tested in the following conditions:
Cooling Conditions: indoor air inlet temperature: 27℃ DB 19℃ WB, outdoor air inlet temperature: 35℃ DB, pipe length: 7.5m, pipe height difference: 0m.
Heating Conditions: indoor air inlet temperature: 20℃ DB, outdoor air inlet temperature: 7℃ DB 6℃ WB, pipe Length: 7.5m, pipe height difference: 0m.
- The above noise values are measured in the anechoic chamber without reflected echo, therefore the impact of the reflected echo must be included at the scene.
Measurement point: 1m from the service cover surface and 1.5m from the floor level.
- When the connection ratio is lower than 50% or higher than 130%, please consult our local technical engineers.

Hi-FLEXi S5 Series



HP		28HP	30HP	32HP	34HP	36HP	
Model		AVWT-272HKF5S	AVWT-290HKF5S	AVWT-307HKF5S	AVWT-324HKF5S	AVWT-343HKF5S	
		AVWT-272HKF5S	AVWT-290HKF5S	AVWT-307HKF5S	AVWT-324HKF5S	AVWT-343HKF5S	
Modules		/	/	/	/	/	
		/	/	/	/	/	
		/	/	/	/	/	
Power Supply		380-415V 3~ 50Hz/60Hz					
Cooling	Capacity*1						
		kW	78.5	85.0	90.0	95.4	100.0
		kBtu/h	267.8	290.0	307.0	325.5	341.2
	Power Input	kW	25.65	30.25	31.69	34.69	36.63
	EER	kW/kW	3.06	2.81	2.84	2.75	2.73
SEER	kW/kW	6.30	6.00	5.90	5.80	5.80	
Heating	Capacity (Max/Nom)*1						
		kW	87.5/78.5	95/85	100/90	106.5/95.4	113/100
		kBtu/h	298.5/267.8	324.1/290	341.2/307	363.3/325.5	385.5/341.2
	Power Input (Max/Nom)	kW	20.73/17.72	23.23/19.63	24.75/20.36	27.88/22.88	31.48/24.27
	COP (Max/Nom)	kW/kW	4.22/4.43	4.09/4.33	4.04/4.42	3.82/4.17	3.59/4.12
SCOP	kW/kW	4.55	4.35	4.51	4.26	4.28	
Ventilation	Air Flow Rate	m ³ /min	408	408	467	467	467
	Fan Quantity	pcs	2	2	2	2	2
	Static Pressure	Pa	110	110	110	110	110
Sound Pressure Level*2	Normal Mode	dB(A)	67	67	67	68	68
	Silent Mode	dB(A)	40	40	40	40	40
Compressor	Type	Enhanced Vapor Injection Scroll Compressor					
	Quantity	pcs	2	2	2	2	2
Refrigerant	Type	R410A					
	Pre-charged Amount	kg	15.5	15.5	16.1	16.1	16.1
Weight	Net Weight	kg	482	482	482	493	493
	Gross Weight	kg	519	519	519	530	530
Dimensions	External (H × W × D)	mm	1800x1880x825				
	Packing (H × W × D)	mm	1960x1940x885				
Cabinet Color		Gray + White					
Ref. Piping	Gas Pipe	mm	φ31.75	φ31.75	φ31.75	φ31.75	φ38.1
		inch	1-1/4	1-1/4	1-1/4	1-1/4	1-1/2
	Liquid Pipe	mm	φ19.05	φ19.05	φ19.05	φ19.05	φ19.05
		inch	3/4	3/4	3/4	3/4	3/4
Connectable Indoor Units	Quantity	pcs	56	60	64	68	72
	Connection Ratio*3		30-200%				
Piping Design	Max. Piping Length (Actual)	m	220	220	220	220	220
	Max. Piping Length (Equivalent)	m	260	260	260	260	260
	Height Difference between ODU and IDU	m	110	110	110	110	110
	Height Difference between IDUs	m	40	40	40	40	40
Operation Range	Cooling	℃	-15℃ DB ~55℃ DB	-15℃ DB ~55℃ DB	-15℃ DB ~55℃ DB	-15℃ DB ~55℃ DB	-15℃ DB ~55℃ DB
	Heating	℃	-30℃ WB ~30℃ DB	-30℃ WB ~30℃ DB	-30℃ WB ~30℃ DB	-30℃ WB ~30℃ DB	-30℃ WB ~30℃ DB

Notes:

- Rated cooling capacity and rated heating capacity are tested in the following conditions:
Cooling Conditions: indoor air inlet temperature: 27℃ DB 19℃ WB, outdoor air inlet temperature: 35℃ DB, pipe length: 7.5m, pipe height difference: 0m.
Heating Conditions: indoor air inlet temperature: 20℃ DB, outdoor air inlet temperature: 7℃ DB 6℃ WB, pipe Length: 7.5m, pipe height difference: 0m.
- The above noise values are measured in the anechoic chamber without reflected echo, therefore the impact of the reflected echo must be included at the scene.
Measurement point: 1m from the service cover surface and 1.5m from the floor level.
- When the connection ratio is lower than 50% or higher than 130%, please consult our local technical engineers.

Hi-FLEXi S5 Series



HP		38HP	40HP	42HP	44HP	
Model		AVWT-366HKF5S	AVWT-386HKF5S	AVWT-402HKF5S	AVWT-424HKF5S	
		AVWT-154HKF5S	AVWT-154HKF5S	AVWT-170HKF5S	AVWT-212HKF5S	
Modules		AVWT-212HKF5S	AVWT-232HKF5S	AVWT-232HKF5S	AVWT-212HKF5S	
		/	/	/	/	
		/	/	/	/	
Power Supply		380-415V 3~ 50Hz/60Hz				
Cooling	Capacity*1					
		kW	106.5	113.0	118.4	123.0
		kBtu/h	363.3	385.5	403.9	419.6
	Power Input	kW	34.51	37.79	36.94	38.92
	EER	kW/kW	3.09	2.99	3.21	3.16
SEER	kW/kW	6.95	6.68	6.68	6.80	
Heating	Capacity (Max/Nom)*1					
		kW	119/106.5	125/113	131/118.4	138/123
		kBtu/h	406/363.3	426.5/385.5	447/403.9	470.8/419.6
	Power Input (Max/Nom)	kW	32.03/24.71	34.13/26.37	34.97/26.26	36.12/27.04
	COP (Max/Nom)	kW/kW	3.72/4.31	3.66/4.29	3.75/4.51	3.82/4.55
SCOP	kW/kW	4.70	4.69	4.81	4.86	
Ventilation	Air Flow Rate	m ³ /min	609	609	575	634
	Fan Quantity	pcs	3	3	3	4
	Static Pressure	Pa	110	110	110	110
Sound Pressure Level*2	Normal Mode	dB(A)	69	69	69	69
	Silent Mode	dB(A)	43	43	43	43
Compressor	Type	Enhanced Vapor Injection Scroll Compressor				
	Quantity	pcs	3	3	3	4
Refrigerant	Type	R410A				
	Pre-charged Amount	kg	20.2	20.7	22.5	25.2
Weight	Net Weight	kg	245+368	245+368	267+368	368+368
	Gross Weight	kg	269+399	269+399	289+399	399+399
Dimensions	External (H × W × D)	mm	1800x(1390+940)x825			1800x(1390+1390)x825
	Packing (H × W × D)	mm	1960x(1450+1000)x885			1960x(1450+1450)x885
Cabinet Color		Gray + White				
Ref. Piping	Gas Pipe	mm	φ38.1	φ38.1	φ38.1	φ38.1
		inch	1-1/2	1-1/2	1-1/2	1-1/2
	Liquid Pipe	mm	φ19.05	φ19.05	φ19.05	φ19.05
		inch	3/4	3/4	3/4	3/4
Connectable Indoor Units	Quantity	pcs	76	80	84	88
	Connection Ratio*3		30-150%			
Piping Design	Max. Piping Length (Actual)	m	220	220	220	220
	Max. Piping Length (Equivalent)	m	260	260	260	260
	Height Difference between ODU and IDU	m	110	110	110	110
	Height Difference between IDUs	m	40	40	40	40
Operation Range	Cooling	℃	-15℃ DB ~55℃ DB	-15℃ DB ~55℃ DB	-15℃ DB ~55℃ DB	-15℃ DB ~55℃ DB
	Heating	℃	-30℃ WB ~30℃ DB	-30℃ WB ~30℃ DB	-30℃ WB ~30℃ DB	-30℃ WB ~30℃ DB

Notes:

- Rated cooling capacity and rated heating capacity are tested in the following conditions:
Cooling Conditions: indoor air inlet temperature: 27℃ DB 19℃ WB, outdoor air inlet temperature: 35℃ DB, pipe length: 7.5m, pipe height difference: 0m.
Heating Conditions: indoor air inlet temperature: 20℃ DB, outdoor air inlet temperature: 7℃ DB 6℃ WB, pipe Length: 7.5m, pipe height difference: 0m.
- The above noise values are measured in the anechoic chamber without reflected echo, therefore the impact of the reflected echo must be included at the scene.
Measurement point: 1m from the service cover surface and 1.5m from the floor level.
- When the connection ratio is lower than 50% or higher than 130%, please consult our local technical engineers.

Hi-FLEXi S5 Series



HP		46HP	48HP	50HP	52HP	
Model		AVWT-444HKF5S	AVWT-464HKF5S	AVWT-482HKF5S	AVWT-500HKF5S	
Modules		AVWT-212HKF5S	AVWT-232HKF5S	AVWT-232HKF5S	AVWT-250HKF5S	
		AVWT-232HKF5S	AVWT-232HKF5S	AVWT-250HKF5S	AVWT-250HKF5S	
		/	/	/	/	
Power Supply		380-415V 3~50Hz/60Hz				
Cooling	Capacity*1	kW	129.5	136.0	141.5	147.0
		kBtu/h	441.8	464.0	482.7	501.4
	Power Input	kW	42.20	45.48	47.83	50.18
	EER	kW/kW	3.07	2.99	2.96	2.93
	SEER	kW/kW	6.58	6.40	6.07	5.80
Heating	Capacity (Max/Nom)*1	kW	144/129.5	150/136	157.5/141.5	165/147
		kBtu/h	491.3/441.8	511.8/464	537.3/482.7	562.8/501.4
	Power Input (Max/Nom)	kW	38.22/28.7	40.32/30.36	41.48/31.12	42.64/31.88
	COP (Max/Nom)	kW/kW	3.77/4.51	3.72/4.48	3.80/4.55	3.87/4.61
	SCOP	kW/kW	4.85	4.84	4.53	4.27
Ventilation	Air Flow Rate	m ³ /min	634	634	717	800
	Fan Quantity	pcs	4	4	4	4
	Static Pressure	Pa	110	110	110	110
Sound Pressure Level*2	Normal Mode	dB(A)	69	69	69	69
	Silent Mode	dB(A)	43	43	43	43
Compressor	Type	—	Enhanced Vapor Injection Scroll Compressor			
	Quantity	pcs	4	4	4	4
Refrigerant	Type	—	R410A			
	Pre-charged Amount	kg	25.7	26.2	24.6	23
Weight	Net Weight	kg	368+368	368+368	406+368	406+406
	Gross Weight	kg	399+399	399+399	430+399	430+430
Dimensions	External (H×W×D)	mm	1800x(1390+1390)x825		1800x(1600+1390)x825	1800x(1600+1600)x825
	Packing (H×W×D)	mm	1960x(1450+1450)x885		1960x(1660+1450)x885	1960x(1660+1660)x885
Cabinet Color	—	Gray + White				
Ref. Piping	Gas Pipe	mm	φ38.1	φ41.3	φ41.3	φ41.3
		inch	1-1/2	1-5/8	1-5/8	1-5/8
	Liquid Pipe	mm	φ19.05	φ22.2	φ22.2	φ22.2
		inch	3/4	7/8	7/8	7/8
Connectable Indoor Units	Quantity	pcs	93	97	101	105
	Connection Ratio*3	—	30~150%			
Piping Design	Max. Piping Length (Actual)	m	220	220	220	220
	Max. Piping Length (Equivalent)	m	260	260	260	260
	Height Difference between ODU and IDU	m	110	110	110	110
	Height Difference between IDUs	m	40	40	40	40
Operation Range	Cooling	℃	-15℃ DB ~55℃ DB	-15℃ DB ~55℃ DB	-15℃ DB ~55℃ DB	-15℃ DB ~55℃ DB
	Heating	℃	-30℃ WB ~30℃ DB	-30℃ WB ~30℃ DB	-30℃ WB ~30℃ DB	-30℃ WB ~30℃ DB

- Notes:
- Rated cooling capacity and rated heating capacity are tested in the following conditions:
Cooling Conditions: indoor air inlet temperature: 27℃ DB 19℃ WB, outdoor air inlet temperature: 35℃ DB, pipe length: 7.5m, pipe height difference: 0m.
Heating Conditions: indoor air inlet temperature: 20℃ DB, outdoor air inlet temperature: 7℃ DB 6℃ WB, pipe Length: 7.5m, pipe height difference: 0m.
 - The above noise values are measured in the anechoic chamber without reflected echo, therefore the impact of the reflected echo must be included at the scene.
Measurement point: 1m from the service cover surface and 1.5m from the floor level.
 - When the connection ratio is lower than 50% or higher than 130%, please consult our local technical engineers.

Hi-FLEXi S5 Series



HP		54HP	56HP	58HP	60HP	62HP	
Model		AVWT-522HKF5S	AVWT-540HKF5S	AVWT-557HKF5S	AVWT-574HKF5S	AVWT-593HKF5S	
Modules		AVWT-250HKF5S	AVWT-250HKF5S	AVWT-250HKF5S	AVWT-250HKF5S	AVWT-250HKF5S	
		AVWT-272HKF5S	AVWT-290HKF5S	AVWT-307HKF5S	AVWT-324HKF5S	AVWT-343HKF5S	
		/	/	/	/	/	
Power Supply		380-415V 3~50Hz/60Hz					
Cooling	Capacity*1	kW	152.0	158.5	163.5	168.9	173.5
		kBtu/h	518.5	540.7	557.7	576.2	591.9
	Power Input	kW	50.74	55.34	56.78	59.78	61.72
	EER	kW/kW	3.00	2.86	2.88	2.83	2.81
	SEER	kW/kW	6.05	5.91	5.85	5.80	5.80
Heating	Capacity (Max/Nom)*1	kW	170/152	177.5/158.5	182.5/163.5	189/168.9	195.5/173.5
		kBtu/h	579.9/518.5	605.5/540.7	622.6/557.7	644.7/576.2	666.9/591.9
	Power Input (Max/Nom)	kW	42.05/33.66	44.55/35.57	46.07/36.3	49.2/38.82	52.8/40.21
	COP (Max/Nom)	kW/kW	4.04/4.52	3.98/4.46	3.96/4.50	3.84/4.35	3.70/4.31
	SCOP	kW/kW	4.41	4.31	4.40	4.26	4.28
Ventilation	Air Flow Rate	m ³ /min	808	808	867	867	867
	Fan Quantity	pcs	4	4	4	4	4
	Static Pressure	Pa	110	110	110	110	110
Sound Pressure Level*2	Normal Mode	dB(A)	70	70	70	71	71
	Silent Mode	dB(A)	43	43	43	43	43
Compressor	Type	—	Enhanced Vapor Injection Scroll Compressor				
	Quantity	pcs	4	4	4	4	4
Refrigerant	Type	—	R410A				
	Pre-charged Amount	kg	27	27	27.6	27.6	27.6
Weight	Net Weight	kg	406+482	406+482	406+482	406+493	406+493
	Gross Weight	kg	430+519	430+519	430+519	430+530	430+530
Dimensions	External (H×W×D)	mm	1800x(1880+1600)x825				
	Packing (H×W×D)	mm	1960x(1940+1660)x885				
Cabinet Color	—	Gray + White					
Ref. Piping	Gas Pipe	mm	φ41.3	φ41.3	φ44.5	φ44.5	φ44.5
		inch	1-5/8	1-5/8	1-3/4	1-3/4	1-3/4
	Liquid Pipe	mm	φ22.2	φ22.2	φ22.2	φ22.2	φ22.2
		inch	7/8	7/8	7/8	7/8	7/8
Connectable Indoor Units	Quantity	pcs	109	113	117	121	125
	Connection Ratio*3	—	30~150%				
Piping Design	Max. Piping Length (Actual)	m	220	220	220	220	220
	Max. Piping Length (Equivalent)	m	260	260	260	260	260
	Height Difference between ODU and IDU	m	110	110	110	110	110
	Height Difference between IDUs	m	40	40	40	40	40
Operation Range	Cooling	℃	-15℃ DB ~55℃ DB	-15℃ DB ~55℃ DB	-15℃ DB ~55℃ DB	-15℃ DB ~55℃ DB	-15℃ DB ~55℃ DB
	Heating	℃	-30℃ WB ~30℃ DB	-30℃ WB ~30℃ DB	-30℃ WB ~30℃ DB	-30℃ WB ~30℃ DB	-30℃ WB ~30℃ DB

- Notes:
- Rated cooling capacity and rated heating capacity are tested in the following conditions:
Cooling Conditions: indoor air inlet temperature: 27℃ DB 19℃ WB, outdoor air inlet temperature: 35℃ DB, pipe length: 7.5m, pipe height difference: 0m.
Heating Conditions: indoor air inlet temperature: 20℃ DB, outdoor air inlet temperature: 7℃ DB 6℃ WB, pipe Length: 7.5m, pipe height difference: 0m.
 - The above noise values are measured in the anechoic chamber without reflected echo, therefore the impact of the reflected echo must be included at the scene.
Measurement point: 1m from the service cover surface and 1.5m from the floor level.
 - When the connection ratio is lower than 50% or higher than 130%, please consult our local technical engineers.

Hi-FLEXi S5 Series



HP		64HP	66HP	68HP	70HP	72HP	
Model		AVWT-614HKF5S	AVWT-631HKF5S	AVWT-650HKF5S	AVWT-667HKF5S	AVWT-686HKF5S	
Modules		AVWT-307HKF5S	AVWT-307HKF5S	AVWT-307HKF5S	AVWT-324HKF5S	AVWT-343HKF5S	
		AVWT-307HKF5S	AVWT-324HKF5S	AVWT-343HKF5S	AVWT-343HKF5S	AVWT-343HKF5S	
		/	/	/	/	/	
Power Supply		380-415V 3~ 50Hz/60Hz					
Cooling	Capacity*1	kW	180.0	185.4	190.0	195.4	200.0
		kBtu/h	614.0	632.5	648.2	666.7	682.4
	Power Input	kW	63.38	66.38	68.32	71.32	73.26
	EER	kW/kW	2.84	2.79	2.78	2.74	2.73
	SEER	kW/kW	5.90	5.85	5.85	5.80	5.80
Heating	Capacity (Max/Nom)*1	kW	200/180	206.5/185.4	213/190	219.5/195.4	226/200
		kBtu/h	682.4/614	704.5/632.5	726.7/648.2	748.8/666.7	771/682.4
	Power Input (Max/Nom)	kW	49.5/40.72	52.63/43.24	56.23/44.63	59.36/47.15	62.96/48.54
	COP (Max/Nom)	kW/kW	4.04/4.42	3.92/4.29	3.79/4.26	3.70/4.14	3.59/4.12
	SCOP	kW/kW	4.51	4.38	4.39	4.27	4.28
Ventilation	Air Flow Rate	m³/min	934	934	934	934	934
	Fan Quantity	pcs	4	4	4	4	4
	Static Pressure	Pa	110	110	110	110	110
Sound Pressure Level*2	Normal Mode	dB(A)	71	71	71	71	71
	Silent Mode	dB(A)	43	43	43	43	43
Compressor	Type	—	Enhanced Vapor Injection Scroll Compressor				
	Quantity	pcs	4	4	4	4	4
Refrigerant	Type	—	R410A				
	Pre-charged Amount	kg	32.2	32.2	32.2	32.2	32.2
Weight	Net Weight	kg	482+482	482+493	482+493	493+493	493+493
	Gross Weight	kg	519+519	519+530	519+530	530+530	530+530
Dimensions	External (H × W × D)	mm	1800x(1880+1880)x825				
	Packing (H × W × D)	mm	1960x(1940+1940)x885				
Cabinet Color	—	Gray + White					
Ref. Piping	Gas Pipe	mm	φ44.5	φ44.5	φ44.5	φ44.5	φ44.5
		inch	1-3/4	1-3/4	1-3/4	1-3/4	1-3/4
	Liquid Pipe	mm	φ22.2	φ22.2	φ22.2	φ22.2	φ22.2
		inch	7/8	7/8	7/8	7/8	7/8
Connectable Indoor Units	Quantity	pcs	128	128	128	128	128
	Connection Ratio*3	—	30-150%				
Piping Design	Max. Piping Length (Actual)	m	220	220	220	220	220
	Max. Piping Length (Equivalent)	m	260	260	260	260	260
	Height Difference between ODU and IDU	m	110	110	110	110	110
	Height Difference between IDUs	m	40	40	40	40	40
Operation Range	Cooling	℃	-15℃ DB ~55℃ DB	-15℃ DB ~55℃ DB	-15℃ DB ~55℃ DB	-15℃ DB ~55℃ DB	-15℃ DB ~55℃ DB
	Heating	℃	-30℃ WB ~30℃ DB	-30℃ WB ~30℃ DB	-30℃ WB ~30℃ DB	-30℃ WB ~30℃ DB	-30℃ WB ~30℃ DB

Notes:

- Rated cooling capacity and rated heating capacity are tested in the following conditions:
Cooling Conditions: indoor air inlet temperature: 27℃ DB 19℃ WB, outdoor air inlet temperature: 35℃ DB, pipe length: 7.5m, pipe height difference: 0m.
Heating Conditions: indoor air inlet temperature: 20℃ DB, outdoor air inlet temperature: 7℃ DB 6℃ WB, pipe Length: 7.5m, pipe height difference: 0m.
- The above noise values are measured in the anechoic chamber without reflected echo, therefore the impact of the reflected echo must be included at the scene.
Measurement point: 1m from the service cover surface and 1.5m from the floor level.
- When the connection ratio is lower than 50% or higher than 130%, please consult our local technical engineers.

Hi-FLEXi S5 Series



HP		74HP	76HP	78HP	80HP	
Model		AVWT-714HKF5S	AVWT-732HKF5S	AVWT-750HKF5S	AVWT-772HKF5S	
Modules		AVWT-232HKF5S	AVWT-232HKF5S	AVWT-250HKF5S	AVWT-250HKF5S	
		AVWT-232HKF5S	AVWT-250HKF5S	AVWT-250HKF5S	AVWT-250HKF5S	
		AVWT-250HKF5S	AVWT-250HKF5S	AVWT-250HKF5S	AVWT-272HKF5S	
Power Supply		380-415V 3~ 50Hz/60Hz				
Cooling	Capacity*1	kW	209.5	215.0	220.5	225.5
		kBtu/h	714.7	733.4	752.1	769.2
	Power Input	kW	70.57	72.92	75.27	75.83
	EER	kW/kW	2.97	2.95	2.93	2.97
	SEER	kW/kW	6.18	5.98	5.80	5.96
Heating	Capacity (Max/Nom)*1	kW	232.5/209.5	240/215	247.5/220.5	252.5/225.5
		kBtu/h	793.2/714.7	818.7/733.4	844.2/752.1	861.3/769.2
	Power Input (Max/Nom)	kW	61.64/46.3	62.8/47.06	63.96/47.82	63.37/49.6
	COP (Max/Nom)	kW/kW	3.77/4.52	3.82/4.57	3.87/4.61	3.98/4.55
	SCOP	kW/kW	4.62	4.44	4.27	4.36
Ventilation	Air Flow Rate	m³/min	1034	1117	1200	1208
	Fan Quantity	pcs	6	6	6	6
	Static Pressure	Pa	110	110	110	110
Sound Pressure Level*2	Normal Mode	dB(A)	71	71	71	72
	Silent Mode	dB(A)	45	45	45	45
Compressor	Type	—	Enhanced Vapor Injection Scroll Compressor			
	Quantity	pcs	6	6	6	6
Refrigerant	Type	—	R410A			
	Pre-charged Amount	kg	37.7	36.1	34.5	38.5
Weight	Net Weight	kg	406+368+368	406+406+368	406+406+406	482+406+406
	Gross Weight	kg	430+399+399	430+430+399	430+430+430	519+430+430
Dimensions	External (H × W × D)	mm	1800x(1390+1390+1600)x825	1800x(1600+1600+1390)x825	1800x(1600+1600+1600)x825	1800x(1880+1600+1600)x825
	Packing (H × W × D)	mm	1960x(1450+1450+1660)x885	1960x(1660+1660+1450)x885	1960x(1660+1660+1660)x885	1960x(1940+1660+1660)x885
Cabinet Color	—	Gray + White				
Ref. Piping	Gas Pipe	mm	φ44.5	φ44.5	φ44.5	φ44.5
		inch	1-3/4	1-3/4	1-3/4	1-3/4
	Liquid Pipe	mm	φ22.2	φ22.2	φ22.2	φ22.2
		inch	7/8	7/8	7/8	7/8
Connectable Indoor Units	Quantity	pcs	128	128	128	128
	Connection Ratio*3	—	30-130%			
Piping Design	Max. Piping Length (Actual)	m	220	220	220	220
	Max. Piping Length (Equivalent)	m	260	260	260	260
	Height Difference between ODU and IDU	m	110	110	110	110
	Height Difference between IDUs	m	40	40	40	40
Operation Range	Cooling	℃	-15℃ DB ~55℃ DB	-15℃ DB ~55℃ DB	-15℃ DB ~55℃ DB	-15℃ DB ~55℃ DB
	Heating	℃	-30℃ WB ~30℃ DB	-30℃ WB ~30℃ DB	-30℃ WB ~30℃ DB	-30℃ WB ~30℃ DB

Notes:

- Rated cooling capacity and rated heating capacity are tested in the following conditions:
Cooling Conditions: indoor air inlet temperature: 27℃ DB 19℃ WB, outdoor air inlet temperature: 35℃ DB, pipe length: 7.5m, pipe height difference: 0m.
Heating Conditions: indoor air inlet temperature: 20℃ DB, outdoor air inlet temperature: 7℃ DB 6℃ WB, pipe Length: 7.5m, pipe height difference: 0m.
- The above noise values are measured in the anechoic chamber without reflected echo, therefore the impact of the reflected echo must be included at the scene.
Measurement point: 1m from the service cover surface and 1.5m from the floor level.
- When the connection ratio is lower than 50% or higher than 130%, please consult our local technical engineers.

Hi-FLEXi S5 Series



HP			82HP	84HP	86HP	88HP
Model			AVWT-790HKF5S	AVWT-807HKF5S	AVWT-824HKF5S	AVWT-843HKF5S
Modules			AVWT-250HKF5S	AVWT-250HKF5S	AVWT-250HKF5S	AVWT-250HKF5S
			AVWT-250HKF5S	AVWT-250HKF5S	AVWT-250HKF5S	AVWT-250HKF5S
			AVWT-290HKF5S	AVWT-307HKF5S	AVWT-324HKF5S	AVWT-343HKF5S
Power Supply		380-415V 3~50Hz/60Hz				
Cooling	Capacity*1	kW	232.0	237.0	242.4	247.0
		kBtu/h	791.4	808.4	826.9	842.6
	Power Input	kW	80.43	81.87	84.87	86.81
	EER	kW/kW	2.88	2.89	2.86	2.85
	SEER	kW/kW	5.87	5.84	5.80	5.80
Heating	Capacity (Max/Nom)*1	kW	260/232	265/237	271.5/242.4	278/247
		kBtu/h	886.9/791.4	904/808.4	926.1/826.9	948.3/842.6
	Power Input (Max/Nom)	kW	65.87/51.51	67.39/52.24	70.52/54.76	74.12/56.15
	COP (Max/Nom)	kW/kW	3.95/4.50	3.93/4.54	3.85/4.43	3.75/4.40
	SCOP	kW/kW	4.30	4.36	4.27	4.27
Ventilation	Air Flow Rate	m³/min	1208	1267	1267	1267
	Fan Quantity	pcs	6	6	6	6
	Static Pressure	Pa	110	110	110	110
Sound Pressure Level*2	Normal Mode	dB(A)	72	72	72	72
	Silent Mode	dB(A)	45	45	45	45
Compressor	Type	—	Enhanced Vapor Injection Scroll Compressor			
	Quantity	pcs	6	6	6	6
Refrigerant	Type	—	R410A			
	Pre-charged Amount	kg	38.5	39.1	39.1	39.1
Weight	Net Weight	kg	482+406+406	482+406+406	493+406+406	493+406+406
	Gross Weight	kg	519+430+430	519+430+430	530+430+430	530+430+430
Dimensions	External (H × W × D)	mm	1800x(1880+1600+1600)x825			
	Packing (H × W × D)	mm	1960x(1940+1660+1660)x885			
Cabinet Color	Gray + White					
Ref. Piping	Gas Pipe	mm	φ44.5	φ50.8	φ50.8	φ50.8
		inch	1-3/4	2	2	2
	Liquid Pipe	mm	φ22.2	φ25.4	φ25.4	φ25.4
		inch	7/8	1	1	1
Connectable Indoor Units	Quantity	pcs	128	128	128	128
	Connection Ratio*3	—	30-130%			
Piping Design	Max. Piping Length (Actual)	m	220	220	220	220
	Max. Piping Length (Equivalent)	m	260	260	260	260
	Height Difference between ODU and IDU	m	110	110	110	110
	Height Difference between IDUs	m	40	40	40	40
Operation Range	Cooling	℃	-15℃ DB ~55℃ DB	-15℃ DB ~55℃ DB	-15℃ DB ~55℃ DB	-15℃ DB ~55℃ DB
	Heating	℃	-30℃ WB ~30℃ DB	-30℃ WB ~30℃ DB	-30℃ WB ~30℃ DB	-30℃ WB ~30℃ DB

Notes:

- Rated cooling capacity and rated heating capacity are tested in the following conditions:
Cooling Conditions: indoor air inlet temperature: 27℃ DB 19℃ WB, outdoor air inlet temperature: 35℃ DB, pipe length: 7.5m, pipe height difference: 0m.
Heating Conditions: indoor air inlet temperature: 20℃ DB, outdoor air inlet temperature: 7℃ DB 6℃ WB, pipe Length: 7.5m, pipe height difference: 0m.
- The above noise values are measured in the anechoic chamber without reflected echo, therefore the impact of the reflected echo must be included at the scene.
Measurement point: 1m from the service cover surface and 1.5m from the floor level.
- When the connection ratio is lower than 50% or higher than 130%, please consult our local technical engineers.

Hi-FLEXi S5 Series



HP			90HP	92HP	94HP
Model			AVWT-864HKF5S	AVWT-881HKF5S	AVWT-900HKF5S
Modules			AVWT-250HKF5S	AVWT-250HKF5S	AVWT-250HKF5S
			AVWT-307HKF5S	AVWT-307HKF5S	AVWT-307HKF5S
			AVWT-307HKF5S	AVWT-324HKF5S	AVWT-343HKF5S
Power Supply		380-415V 3~50Hz/60Hz			
Cooling	Capacity*1	kW	253.5	258.9	263.5
		kBtu/h	864.7	883.2	898.9
	Power Input	kW	88.47	91.47	93.41
	EER	kW/kW	2.87	2.83	2.82
	SEER	kW/kW	5.87	5.83	5.83
Heating	Capacity (Max/Nom)*1	kW	282.5/253.5	289/258.9	295.5/263.5
		kBtu/h	963.8/864.7	985.9/883.2	1008.1/898.9
	Power Input (Max/Nom)	kW	70.82/56.66	73.95/59.18	77.55/60.57
	COP (Max/Nom)	kW/kW	3.99/4.47	3.91/4.37	3.81/4.35
	SCOP	kW/kW	4.44	4.35	4.35
Ventilation	Air Flow Rate	m³/min	1334	1334	1334
	Fan Quantity	pcs	6	6	6
	Static Pressure	Pa	110	110	110
Sound Pressure Level*2	Normal Mode	dB(A)	72	72	72
	Silent Mode	dB(A)	45	45	45
Compressor	Type	—	Enhanced Vapor Injection Scroll Compressor		
	Quantity	pcs	6	6	6
Refrigerant	Type	—	R410A		
	Pre-charged Amount	kg	43.7	43.7	43.7
Weight	Net Weight	kg	482+482+406	493+482+406	493+482+406
	Gross Weight	kg	519+519+430	530+519+430	530+519+430
Dimensions	External (H × W × D)	mm	1800x(1880+1880+1600)x825		
	Packing (H × W × D)	mm	1960x(1940+1940+1660)x885		
Cabinet Color	Gray + White				
Ref. Piping	Gas Pipe	mm	φ50.8	φ50.8	φ50.8
		inch	2	2	2
	Liquid Pipe	mm	φ25.4	φ25.4	φ25.4
		inch	1	1	1
Connectable Indoor Units	Quantity	pcs	128	128	128
	Connection Ratio*3	—	30-130%		
Piping Design	Max. Piping Length (Actual)	m	220	220	220
	Max. Piping Length (Equivalent)	m	260	260	260
	Height Difference between ODU and IDU	m	110	110	110
	Height Difference between IDUs	m	40	40	40
Operation Range	Cooling	℃	-15℃ DB ~55℃ DB	-15℃ DB ~55℃ DB	-15℃ DB ~55℃ DB
	Heating	℃	-30℃ WB ~30℃ DB	-30℃ WB ~30℃ DB	-30℃ WB ~30℃ DB

Notes:

- Rated cooling capacity and rated heating capacity are tested in the following conditions:
Cooling Conditions: indoor air inlet temperature: 27℃ DB 19℃ WB, outdoor air inlet temperature: 35℃ DB, pipe length: 7.5m, pipe height difference: 0m.
Heating Conditions: indoor air inlet temperature: 20℃ DB, outdoor air inlet temperature: 7℃ DB 6℃ WB, pipe Length: 7.5m, pipe height difference: 0m.
- The above noise values are measured in the anechoic chamber without reflected echo, therefore the impact of the reflected echo must be included at the scene.
Measurement point: 1m from the service cover surface and 1.5m from the floor level.
- When the connection ratio is lower than 50% or higher than 130%, please consult our local technical engineers.

Hi-FLEXi S5 Series



HP		96HP	98HP	100HP	102HP	
Model		AVWT-917HKF5S	AVWT-936HKF5S	AVWT-957HKF5S	AVWT-974HKF5S	
Modules		AVWT-250HKF5S	AVWT-250HKF5S	AVWT-307HKF5S	AVWT-307HKF6S	
		AVWT-324HKF5S	AVWT-343HKF5S	AVWT-307HKF5S	AVWT-324HKF5S	
		AVWT-343HKF5S	AVWT-343HKF5S	AVWT-343HKF5S	AVWT-343HKF5S	
Power Supply		380-415V 3~ 50Hz/60Hz				
Cooling	Capacity*1	kW	268.9	273.5	280.0	285.4
		kBtu/h	917.4	933.1	955.2	973.7
	Power Input	kW	96.41	98.35	100.01	103.01
	EER	kW/kW	2.79	2.78	2.80	2.77
	SEER	kW/kW	5.80	5.80	5.86	5.83
Heating	Capacity (Max/Nom)*1	kW	302/268.9	308.5/273.5	313/280	319.5/285.4
		kBtu/h	1030.2/917.4	1052.4/933.1	1067.9/955.2	1090/973.7
	Power Input (Max/Nom)	kW	80.68/63.09	84.28/64.48	80.98/64.99	84.11/67.51
	COP (Max/Nom)	kW/kW	3.74/4.26	3.66/4.24	3.87/4.31	3.8/4.23
	SCOP	kW/kW	4.27	4.28	4.43	4.34
Ventilation	Air Flow Rate	m³/min	1334	1334	1401	1401
	Fan Quantity	pcs	6	6	6	6
	Static Pressure	Pa	110	110	110	110
Sound Pressure Level*2	Normal Mode	dB(A)	73	73	73	73
	Silent Mode	dB(A)	45	45	45	45
Compressor	Type	—	Enhanced Vapor Injection Scroll Compressor			
	Quantity	pcs	6	6	6	6
Refrigerant	Type	—	R410A			
	Pre-charged Amount	kg	43.7	43.7	48.3	48.3
Weight	Net Weight	kg	493+493+406	493+493+406	493+482+482	493+493+482
	Gross Weight	kg	530+530+430	530+530+430	530+519+519	530+530+519
Dimensions	External (H × W × D)	mm	1800x(1880+1880+1600)x825		1800x(1880+1880+1880)x825	
	Packing (H × W × D)	mm	1960x(1940+1940+1660)x885		1960x(1940+1940+1940)x885	
Cabinet Color	—	Gray + White				
Ref. Piping	Gas Pipe	mm	φ50.8	φ50.8	φ50.8	φ50.8
		inch	2	2	2	2
	Liquid Pipe	mm	φ25.4	φ25.4	φ25.4	φ25.4
		inch	1	1	1	1
Connectable Indoor Units	Quantity	pcs	128	128	128	128
	Connection Ratio*3	—	30-130%			
Piping Design	Max. Piping Length (Actual)	m	220	220	220	220
	Max. Piping Length (Equivalent)	m	260	260	260	260
	Height Difference between ODU and IDU	m	110	110	110	110
	Height Difference between IDUs	m	40	40	40	40
Operation Range	Cooling	℃	-15℃ DB ~55℃ DB	-15℃ DB ~55℃ DB	-15℃ DB ~55℃ DB	-15℃ DB ~55℃ DB
	Heating	℃	-30℃ WB ~30℃ DB	-30℃ WB ~30℃ DB	-30℃ WB ~30℃ DB	-30℃ WB ~30℃ DB

Notes:
 1. Rated cooling capacity and rated heating capacity are tested in the following conditions:
 Cooling Conditions: indoor air inlet temperature: 27℃ DB 19℃ WB, outdoor air inlet temperature: 35℃ DB, pipe length: 7.5m, pipe height difference: 0m.
 Heating Conditions: indoor air inlet temperature: 20℃ DB, outdoor air inlet temperature: 7℃ DB 6℃ WB, pipe Length: 7.5m, pipe height difference: 0m.
 2. The above noise values are measured in the anechoic chamber without reflected echo, therefore the impact of the reflected echo must be included at the scene.
 Measurement point: 1m from the service cover surface and 1.5m from the floor level.
 3. When the connection ratio is lower than 50% or higher than 130%, please consult our local technical engineers.

Hi-FLEXi S5 Series



HP		104HP	106HP	108HP	
Model		AVWT-993HKF5S	AVWT-1010HKF5S	AVWT-1029HKF5S	
Modules		AVWT-307HKF7S	AVWT-324HKF5S	AVWT-343HKF5S	
		AVWT-343HKF5S	AVWT-343HKF5S	AVWT-343HKF5S	
		AVWT-343HKF5S	AVWT-343HKF5S	AVWT-343HKF5S	
Power Supply		380-415V 3~ 50Hz/60Hz			
Cooling	Capacity*1	kW	290.0	295.4	300.0
		kBtu/h	959.4	1007.9	1023.6
	Power Input	kW	104.95	107.95	109.89
	EER	kW/kW	2.76	2.74	2.73
	SEER	kW/kW	5.83	5.80	5.80
Heating	Capacity (Max/Nom)*1	kW	326/290	332.5/295.4	339/300
		kBtu/h	1112.2/959.4	1134.3/1007.9	1156.5/1023.6
	Power Input (Max/Nom)	kW	87.71/68.9	90.84/71.42	94.44/72.81
	COP (Max/Nom)	kW/kW	3.72/4.21	3.66/4.14	3.59/4.12
	SCOP	kW/kW	4.35	4.27	4.28
Ventilation	Air Flow Rate	m³/min	1401	1401	1401
	Fan Quantity	pcs	6	6	6
	Static Pressure	Pa	110	110	110
Sound Pressure Level*2	Normal Mode	dB(A)	73	73	73
	Silent Mode	dB(A)	45	45	45
Compressor	Type	—	Enhanced Vapor Injection Scroll Compressor		
	Quantity	pcs	6	6	6
Refrigerant	Type	—	R410A		
	Pre-charged Amount	kg	48.3	48.3	48.3
Weight	Net Weight	kg	493+493+482	493+493+493	493+493+493
	Gross Weight	kg	530+530+519	530+530+530	530+530+530
Dimensions	External (H × W × D)	mm	1800x(1880+1880+1880)x825		
	Packing (H × W × D)	mm	1960x(1940+1940+1940)x885		
Cabinet Color	—	Gray + White			
Ref. Piping	Gas Pipe	mm	φ50.8	φ50.8	φ50.8
		inch	2	2	2
	Liquid Pipe	mm	φ25.4	φ25.4	φ25.4
		inch	1	1	1
Connectable Indoor Units	Quantity	pcs	128	128	128
	Connection Ratio*3	—	30-130%		
Piping Design	Max. Piping Length (Actual)	m	220	220	220
	Max. Piping Length (Equivalent)	m	260	260	260
	Height Difference between ODU and IDU	m	110	110	110
	Height Difference between IDUs	m	40	40	40
Operation Range	Cooling	℃	-15℃ DB ~55℃ DB	-15℃ DB ~55℃ DB	-15℃ DB ~55℃ DB
	Heating	℃	-30℃ WB ~30℃ DB	-30℃ WB ~30℃ DB	-30℃ WB ~30℃ DB

Notes:
 1. Rated cooling capacity and rated heating capacity are tested in the following conditions:
 Cooling Conditions: indoor air inlet temperature: 27℃ DB 19℃ WB, outdoor air inlet temperature: 35℃ DB, pipe length: 7.5m, pipe height difference: 0m.
 Heating Conditions: indoor air inlet temperature: 20℃ DB, outdoor air inlet temperature: 7℃ DB 6℃ WB, pipe Length: 7.5m, pipe height difference: 0m.
 2. The above noise values are measured in the anechoic chamber without reflected echo, therefore the impact of the reflected echo must be included at the scene.
 Measurement point: 1m from the service cover surface and 1.5m from the floor level.
 3. When the connection ratio is lower than 50% or higher than 130%, please consult our local technical engineers.

Hi-FLEXi **S** Heat Recovery Series



All in One Renewable Energy Solution

With S heat recovery series, cooling and heating of air can be realised simultaneously including water. During summer, it serves cool indoor rooms and warm water supply for night showers. With the same system, floor heating and fan coil unit heating and cooling can be done during season transition periods.

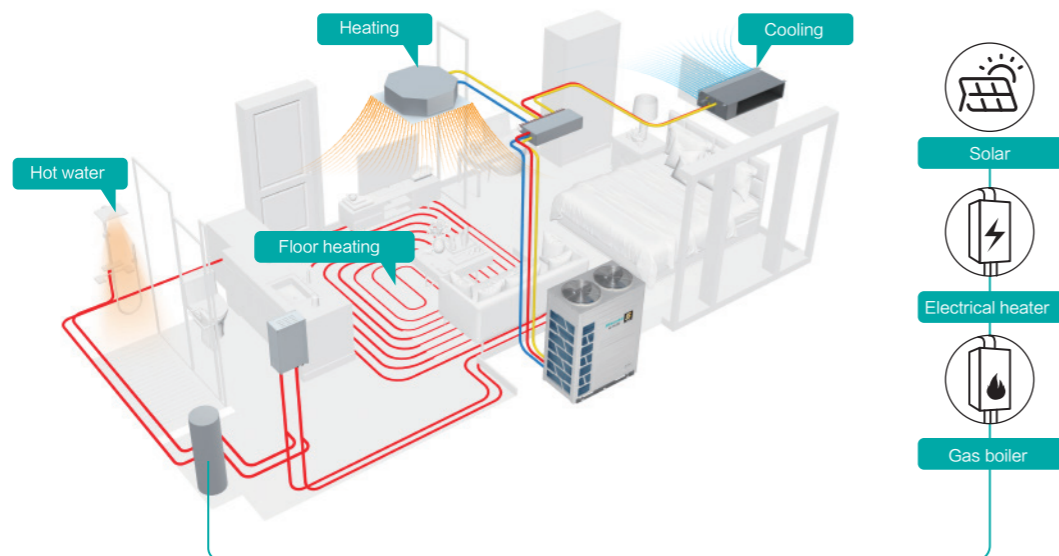

200% Connection Ratio

The powerful S heat recovery series outdoor units are connectable to indoor units up to 2 times of its own capacity with ratio of 200% for a more efficient and cost saving system.

*This feature is subject to a specific condition. For further information, please contact our engineers.



External Static Pressure

External static pressure is reachable up to 110Pa, allowing better air discharge when are installed indoors with ducting or even outdoors in poor air ventilation spaces.

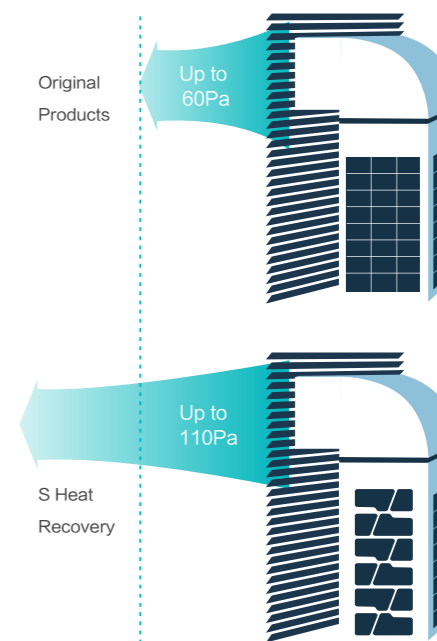

Piping Length

With extra long pipe, the height difference between the indoor unit and outdoor unit is up to 90 meters*, which makes installation more flexible.

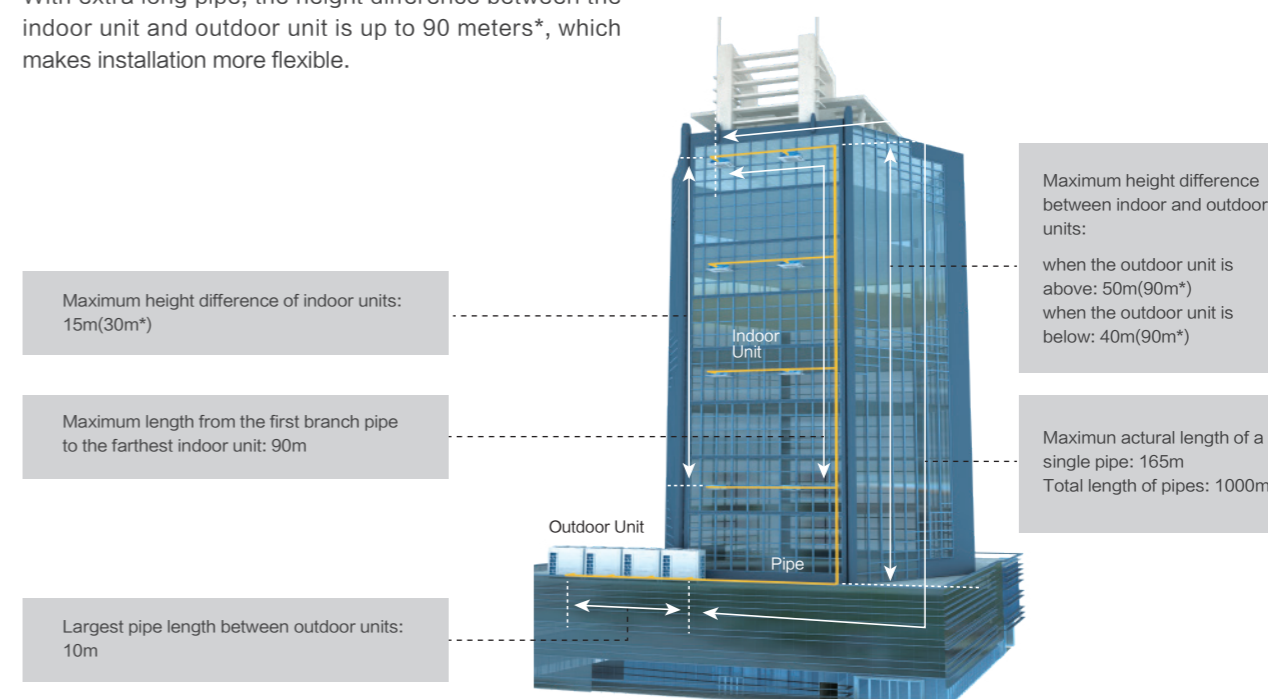

*Note: For detailed information, please contact Hisense's technical staff.

New Upgraded Switch Box

Switch box defies the complicated piping of 3pipe heat recovery systems and simplifies the system with lesser connections and piping including refrigerant and condensate piping. Now with larger capacity up to 85kW for larger systems and increased up to 16 branch ports for more indoor units connections.

Heating Domination Mode

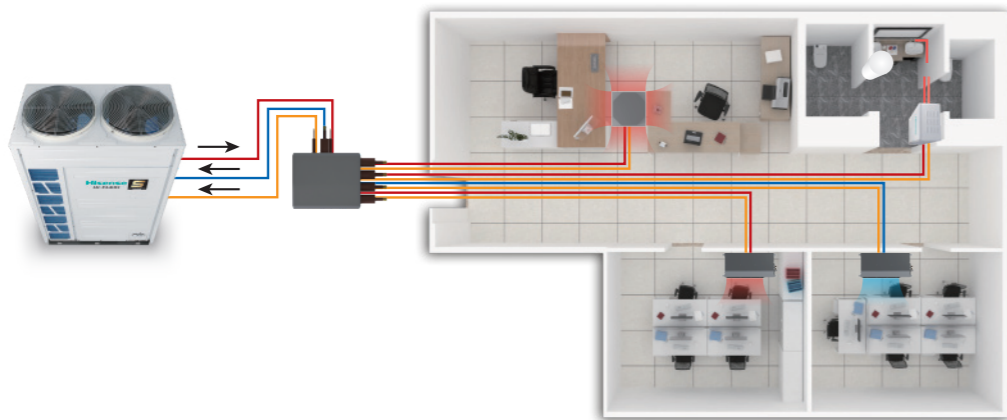

3 Pipes Without Switch Box

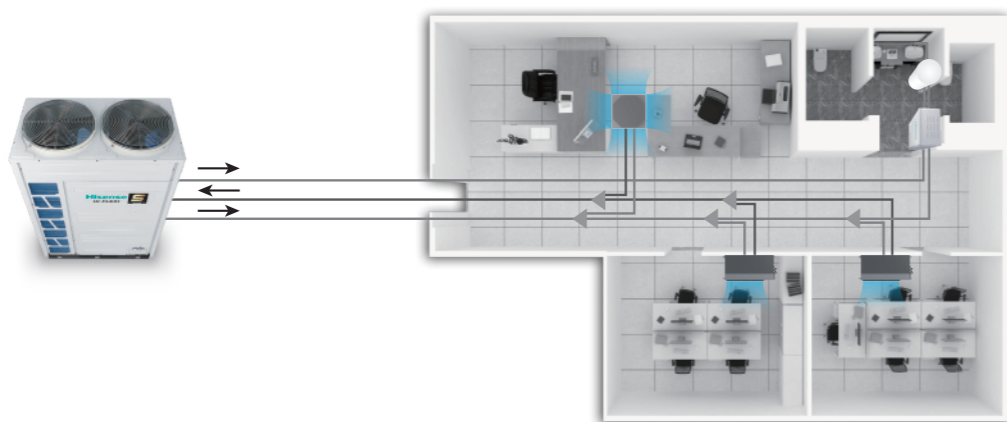

Dual 20RT EEV

Compared with conventional 10RT EEV with 480 steps, dual 20RT EEV with 3000pls can better reduce pressure loss and improve performance.

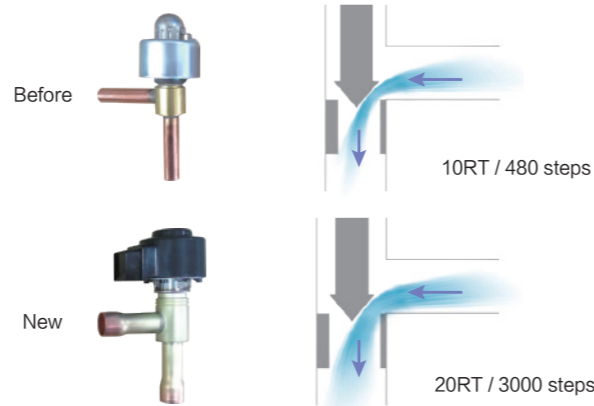
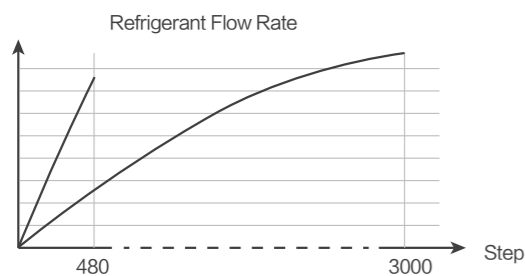

Hi-FLEXi S Heat Recovery (Standard)



		HP	8HP	10HP	12HP	14HP	16HP
Model		Model	AVWT-76FKFSB	AVWT-96FKFSB	AVWT-114FKFSB	AVWT-136FKFSB	AVWT-154FKFSB
Model		Modules	—	—	—	—	—
Power Supply			AC 3Φ, 380-415V/50/60Hz				
Cooling	Capacity	kW	22.4	28.0	33.5	40.0	45.0
		kBtu/h	76.4	95.5	114.3	136.5	153.5
	Power Input	kW	6.81	9.15	11.32	13.75	16.36
	EER	kW/kW	3.30	3.05	2.95	2.91	2.75
	SEER	kW/kW	6.48	7.21	7.19	6.56	6.48
Heating	Capacity (Max/Nom)	kW	25.0/22.4	31.5/28.0	37.5/33.5	45.0/40.0	50.0/45.0
		kBtu/h	85.3/76.4	107.5/95.5	128.0/114.3	153.5/136.5	170.6/153.5
	Power Input (Max/Nom)	kW	7.10/5.83	8.93/7.41	10.68/9.31	13.41/11.24	15.70/12.97
	COP (Max/Nom)	kW/kW	3.52/3.84	3.53/3.78	3.51/3.60	3.36/3.56	3.19/3.47
	SCOP	kW/kW	4.14	4.23	4.24	4.12	4.14
Ventilation	Air Flow Rate	m ³ /min	183	183	183	200	200
	Fan Quantity		1	1	1	2	2
Sound Pressure Level (Normal/ Silent)	Static Pressure	Pa	110	110	110	110	110
		dB(A)	59/49	60/49	62/50	62/53	62/53
Compressor	Type	—	Enhanced Vapor Injection Scroll Compressor				
	Compressor Quantity	pcs	1	1	1	1	1
Refrigerant	Type	—	R410A				
	Pre-charged Quantity	kg	5.60	5.90	6.00	8.80	8.80
Weight	Net Weight	kg	226	227	246	289	290
	Gross Weight	kg	256	257	276	321	322
Dimensions	External(HxWxD)	mm	1730x950x750	1730x950x750	1730x950x750	1730x1210x750	1730x1210x750
	Packing(HxWxD)	mm	1950x1015x790	1950x1015x790	1950x1015x790	1950x1275x790	1950x1275x790
Cabinet Color	Low Pressure Gas Line	mm(in.)	φ 19.05(3/4)	φ 22.20(7/8)	φ 25.40(1)	φ 25.40(1)	φ 28.60(1-1/8)
	High/Low Pressure Gas Line	mm(in.)	φ 15.88(5/8)	φ 19.05(3/4)	φ 22.20(7/8)	φ 22.20(7/8)	φ 22.20(7/8)
	Liquid Line	mm(in.)	φ 9.53(3/8)	φ 9.53(3/8)	φ 12.70(1/2)	φ 12.70(1/2)	φ 12.70(1/2)
Heat Pump Operation System	Gas Line	mm(in.)	φ 19.05(3/4)	φ 22.20(7/8)	φ 25.40(1)	φ 25.40(1)	φ 28.60(1-1/8)
	Liquid Line	mm(in.)	φ 9.53(3/8)	φ 9.53(3/8)	φ 12.70(1/2)	φ 12.70(1/2)	φ 12.70(1/2)
Connectable Indoor Units	Quantity	pcs	13	16	19	23	26
	Total Capacity	—	200%*1	200%*1	200%*1	200%*1	200%*1
Piping Design	Height Difference Between ODU and IDU	m (above)	50(90°)	50(90°)	50(90°)	50(90°)	50(90°)
		m (below)	40(90°)	40(90°)	40(90°)	40(90°)	40(90°)
	Height Difference Between IDUs	m	15(30°)	15(30°)	15(30°)	15(30°)	15(30°)
	Max. Piping Length	m	165	165	165	165	165
Operation Range	Cooling	DB	-10°C-52°C	-10°C-52°C	-10°C-52°C	-10°C-52°C	-10°C-52°C
	Heating	WB	-25°C-16.5°C	-25°C-16.5°C	-25°C-16.5°C	-25°C-16.5°C	-25°C-16.5°C

Notes:

1. Rated cooling capacity and rated heating capacity are tested in the following conditions:

Cooling conditions: indoor air inlet temperature: 27°C DB 19°C WB, outdoor air inlet temperature: 35°C DB, pipe length: 7.5m, pipe height difference: 0m.

Heating conditions: indoor air inlet temperature: 20°C DB, outdoor air inlet temperature: 7°C DB 6°C WB, pipe length: 7.5m, pipe height difference: 0m.

2. The above noise values are measured in the anechoic chamber without reflected echo, therefore the impact of the reflected echo must be included at the scene.

3. The above performance data is obtained on the basis of the performance of this outdoor unit, with a 100%-combination of 4-way cassette type indoor units.

*1*2: For detailed information, please contact with Hisense technical engineers.

Hi-FLEXi S Heat Recovery (Standard)



HP		18HP	20HP	22HP	24HP	
Model		AVWT-170FKFSB	AVWT-190FKFSB	AVWT-212FKFSB	AVWT-232FKFSB	
Modules		—	—	—	—	
Power Supply		AC 3φ, 380-415V/50/60Hz				
Cooling	Capacity	kW	50.0	56.0	61.5	68.0
		kBtu/h	170.6	191.1	209.8	232.0
	Power Input	kW	20.41	23.43	26.74	29.82
	EER	kW/kW	2.45	2.39	2.30	2.28
	SEER	kW/kW	6.46	6.39	6.14	6.10
Heating	Capacity (Max/Nom)	kW	56.0/50.0	63.0/56.0	69.0/61.5	75.0/68.0
		kBtu/h	191.1/170.6	215.0/191.1	235.4/209.8	255.9/232.0
	Power Input (Max/Nom)	kW	17.43/14.71	19.19/16.18	22.26/18.75	25.14/20.92
	COP (Max/Nom)	kW/kW	3.21/3.40	3.28/3.46	3.10/3.28	2.98/3.25
	SCOP	kW/kW	4.21	4.12	4.09	3.97
Ventilation	Air Flow Rate	m ³ /min	200	267	350	350
	Fan Quantity		2	2	2	2
Sound Pressure Level (Normal/ Silent)	Static Pressure	Pa	110	110	110	110
		dB(A)	62/54	63/54	67/54	67/54
Compressor	Type	Enhanced Vapor Injection Scroll Compressor				
	Compressor Quantity	pcs	2	2	2	2
Refrigerant	Type	R410A				
	Pre-charged Quantity	kg	9.20	9.80	11.50	11.50
Weight	Net Weight	kg	349	369	400	401
	Gross Weight	kg	381	404	438	439
Dimensions	External(HxWxD)	mm	1730x1210x750	1730x1350x750	1730 × 1600 × 750	1730 × 1600 × 750
	Packing(HxWxD)	mm	1950x1275x790	1950x1420x790	1950 × 1665 × 790	1950 × 1665 × 790
Cabinet Color		Ivory White				
	Low Pressure Gas Line	mm(in.)	φ28.60(1-1/8)	φ28.60(1-1/8)	φ28.60(1-1/8)	φ28.60(1-1/8)
	High/Low Pressure Gas Line	mm(in.)	φ22.2(7/8)	φ22.2(7/8)	φ25.4(1)	φ25.4(1)
Heat Recovery Operation System	Liquid Line	mm(in.)	φ15.88(5/8)	φ15.88(5/8)	φ15.88(5/8)	φ15.88(5/8)
	Gas Line	mm(in.)	φ28.60(1-1/8)	φ28.60(1-1/8)	φ28.60(1-1/8)	φ28.60(1-1/8)
	Liquid Line	mm(in.)	φ15.88(5/8)	φ15.88(5/8)	φ15.88(5/8)	φ15.88(5/8)
Heat Pump Operation System	Gas Line	mm(in.)	φ28.60(1-1/8)	φ28.60(1-1/8)	φ28.60(1-1/8)	φ28.60(1-1/8)
	Liquid Line	mm(in.)	φ15.88(5/8)	φ15.88(5/8)	φ15.88(5/8)	φ15.88(5/8)
	Quantity	pcs	29	33	36	40
Connectable Indoor Units	Total Capacity	—	200%*1	200%*1	200%*1	200%*1
	Height Difference Between ODU and IDU	m(above)	50(90*2)	50(90*2)	50(90*2)	50(90*2)
Piping Design		m(below)	40(90*2)	40(90*2)	40(90*2)	40(90*2)
	Height Difference Between IDUs	m	15(30*2)	15(30*2)	15(30*2)	15(30*2)
	Max. Piping Length	m	165	165	165	165
Operation Range	Cooling	DB	-10°C~52°C	-10°C~52°C	-10°C~52°C	-10°C~52°C
	Heating	WB	-25°C~16.5°C	-25°C~16.5°C	-25°C~16.5°C	-25°C~16.5°C

Notes:
 1. Rated cooling capacity and rated heating capacity are tested in the following conditions:
 Cooling conditions: indoor air inlet temperature: 27°C DB 19°C WB, outdoor air inlet temperature: 35°C DB, pipe length: 7.5m, pipe height difference: 0m.
 Heating conditions: indoor air inlet temperature: 20°C DB, outdoor air inlet temperature: 7°C DB 6°C WB, pipe length: 7.5m, pipe height difference: 0m.
 2. The above noise values are measured in the anechoic chamber without reflected echo, therefore the impact of the reflected echo must be included at the scene.
 3. The above performance data is obtained on the basis of the performance of this outdoor unit, with a 100%-combination of 4-way cassette type indoor units.
 **2: For detailed information, please contact with Hisense technical engineers.

Hi-FLEXi S Heat Recovery (Standard)



HP		26HP	28HP	30HP	32HP	
Model		AVWT-250FKFSB	AVWT-272FKFSB	AVWT-290FKFSB	AVWT-308FKFSB	
Modules		AVWT-136FKFSB AVWT-114FKFSB	AVWT-136FKFSB AVWT-136FKFSB	AVWT-154FKFSB AVWT-136FKFSB	AVWT-154FKFSB AVWT-154FKFSB	
Power Supply		AC 3φ, 380-415V/50/60Hz				
Cooling	Capacity	kW	73.5	80.0	85.0	90.0
		kBtu/h	250.8	273.0	290.0	307.1
	Power Input	kW	25.07	27.50	30.11	32.72
	EER	kW/kW	2.93	2.91	2.82	2.75
	SEER	kW/kW	82.5/73.5	90.0/80.0	95.0/85.0	100.0/90.0
Heating	Capacity (Max/Nom)	kBtu/h	281.5/250.8	307.1/273.0	324.1/290.0	341.2/307.1
	Power Input (Max/Nom)	kW	24.09/20.56	26.81/22.48	29.10/24.21	31.39/25.94
	COP (Max/Nom)	kW/kW	3.42/3.58	3.36/3.56	3.26/3.51	3.19/3.47
Ventilation	Air Flow Rate	m ³ /min	383	400	400	400
	Fan Quantity		3	4	4	4
Sound Pressure Level (Normal/ Silent)	Static Pressure	Pa	110	110	110	110
		dB(A)	65/55	65/56	65/56	65/56
Compressor	Type	Enhanced Vapor Injection Scroll Compressor				
	Compressor Quantity	pcs	2	2	2	2
Refrigerant	Type	R410A				
	Pre-charged Quantity	kg	14.80	17.60	17.60	17.60
Weight	Net Weight	kg	535	578	579	580
	Gross Weight	kg	597	642	643	644
Dimensions	External(HxWxD)	mm	1730x (950+1210) x750	1730x (1210+1210) x750	1730x (1210+1210) x750	1730x (1210+1210) x750
	Packing(HxWxD)	mm	1950x (1015+1275) x790	1950x (1275+1275) x790	1950x (1275+1275) x790	1950x (1275+1275) x790
	Cabinet Color		Ivory White			
Heat Recovery Operation System	Low Pressure Gas Line	mm(in.)	φ31.75(1-1/4)	φ31.75(1-1/4)	φ31.75(1-1/4)	φ31.75(1-1/4)
	High/Low Pressure Gas Line	mm(in.)	φ25.4(1)	φ28.6(1-1/8)	φ28.6(1-1/8)	φ28.6(1-1/8)
	Liquid Line	mm(in.)	φ19.05(3/4)	φ19.05(3/4)	φ19.05(3/4)	φ19.05(3/4)
Heat Pump Operation System	Gas Line	mm(in.)	φ31.75(1-1/4)	φ31.75(1-1/4)	φ31.75(1-1/4)	φ31.75(1-1/4)
	Liquid Line	mm(in.)	φ19.05(3/4)	φ19.05(3/4)	φ19.05(3/4)	φ19.05(3/4)
	Quantity	pcs	42	46	49	52
Connectable Indoor Units	Total Capacity	—	200%*1	200%*1	200%*1	200%*1
	Height Difference Between ODU and IDU	m(above)	50(90*2)	50(90*2)	50(90*2)	50(90*2)
Piping Design		m(below)	40(90*2)	40(90*2)	40(90*2)	40(90*2)
	Height Difference Between IDUs	m	15(30*2)	15(30*2)	15(30*2)	15(30*2)
	Max. Piping Length	m	165	165	165	165
Operation Range	Cooling	DB	-10°C~52°C	-10°C~52°C	-10°C~52°C	-10°C~52°C
	Heating	WB	-25°C~16.5°C	-25°C~16.5°C	-25°C~16.5°C	-25°C~16.5°C

Notes:
 1. Rated cooling capacity and rated heating capacity are tested in the following conditions:
 Cooling conditions: indoor air inlet temperature: 27°C DB 19°C WB, outdoor air inlet temperature: 35°C DB, pipe length: 7.5m, pipe height difference: 0m.
 Heating conditions: indoor air inlet temperature: 20°C DB, outdoor air inlet temperature: 7°C DB 6°C WB, pipe length: 7.5m, pipe height difference: 0m.
 2. The above noise values are measured in the anechoic chamber without reflected echo, therefore the impact of the reflected echo must be included at the scene.
 3. The above performance data is obtained on the basis of the performance of this outdoor unit, with a 100%-combination of 4-way cassette type indoor units.
 **2: For detailed information, please contact with Hisense technical engineers.

Hi-FLEXi S Heat Recovery (Standard)



HP		34HP	36HP	38HP	40HP	
Model	Model	AVWT-324FKFSB	AVWT-344FKFSB	AVWT-360FKFSB	AVWT-380FKFSB	
	Modules	AVWT-170FKFSB AVWT-154FKFSB	AVWT-190FKFSB AVWT-154FKFSB	AVWT-190FKFSB AVWT-170FKFSB	AVWT-190FKFSB AVWT-190FKFSB	
Power Supply		AC 3 ϕ , 380-415V/50/60Hz				
Cooling	Capacity	95.0	101.0	106.0	112.0	
	Capacity	kW				
	Capacity	kBtu/h	324.1	344.6	361.7	382.1
	Power Input	kW	36.77	39.79	43.84	46.86
EER	kW/kW	2.58	2.54	2.42	2.39	
Heating	Capacity (Max/Nom)	kW	106.0/95.0	113.0/101.0	119.0/106.0	126.0/112.0
	Capacity (Max/Nom)	kBtu/h	361.7/324.1	385.6/344.6	406.0/361.7	429.9/382.1
	Power Input (Max/Nom)	kW	33.13/27.68	34.89/29.15	36.63/30.89	38.39/32.36
COP (Max/Nom)	kW/kW	3.20/3.43	3.24/3.46	3.25/3.43	3.28/3.46	
Ventilation	Air Flow Rate	m ³ /min	400	467	467	534
	Fan Quantity		4	4	4	4
	Static Pressure	Pa	110	110	110	110
Sound Pressure Level (Normal/ Silent)	dB(A)	65/57	66/57	66/57	66/57	
Compressor	Type	Enhanced Vapor Injection Scroll Compressor				
	Compressor Quantity	pcs	3	3	4	4
Refrigerant	Type	R410A				
	Pre-charged Quantity	kg	18.00	18.60	19.00	19.60
Weight	Net Weight	kg	639	659	718	738
	Gross Weight	kg	703	726	785	808
Dimensions	External(HxWxD)	mm	1730x (1210+1210) x750	1730x (1210+1350) x750	1730x (1210+1350) x750	1730x (1350+1350) x750
		Packing(HxWxD)	mm	1950x (1275+1275) x790	1950x (1275+1420) x790	1950x (1275+1420) x790
	Cabinet Color		Ivory White			
		Low Pressure Gas Line	mm(in.)	ϕ 31.75(1-1/4)	ϕ 38.1(1-1/2)	ϕ 38.1(1-1/2)
Heat Recovery Operation System	High/Low Pressure Gas Line	mm(in.)	ϕ 28.6(1-1/8)	ϕ 28.6(1-1/8)	ϕ 31.75(1-1/4)	ϕ 31.75(1-1/4)
	Liquid Line	mm(in.)	ϕ 19.05(3/4)	ϕ 19.05(3/4)	ϕ 19.05(3/4)	ϕ 19.05(3/4)
	Gas Line	mm(in.)	ϕ 31.75(1-1/4)	ϕ 38.1(1-1/2)	ϕ 38.1(1-1/2)	ϕ 38.1(1-1/2)
Heat Pump Operation System	Gas Line	mm(in.)	ϕ 19.05(3/4)	ϕ 19.05(3/4)	ϕ 19.05(3/4)	ϕ 19.05(3/4)
	Liquid Line	mm(in.)	ϕ 19.05(3/4)	ϕ 19.05(3/4)	ϕ 19.05(3/4)	ϕ 19.05(3/4)
Connectable Indoor Units	Quantity	pcs	55	59	64	64
	Total Capacity	-	200%*1	200%*1	200%*1	200%*1
Piping Design	Height Difference Between ODU and IDU	m(above)	50(90*)	50(90*)	50(90*)	50(90*)
		m(below)	40(90*)	40(90*)	40(90*)	40(90*)
	Height Difference Between IDUs	m	15(30*)	15(30*)	15(30*)	15(30*)
		Max. Piping Length	m	165	165	165
Operation Range	Cooling	DB	-10°C-52°C	-10°C-52°C	-10°C-52°C	-10°C-52°C
	Heating	WB	-25°C-16.5°C	-25°C-16.5°C	-25°C-16.5°C	-25°C-16.5°C

Notes:

- Rated cooling capacity and rated heating capacity are tested in the following conditions:
Cooling conditions: indoor air inlet temperature: 27°C DB 19°C WB, outdoor air inlet temperature: 35°C DB, pipe length: 7.5m, pipe height difference: 0m.
Heating conditions: indoor air inlet temperature: 20°C DB, outdoor air inlet temperature: 7°C DB 6°C WB, pipe length: 7.5m, pipe height difference: 0m.
- The above noise values are measured in the anechoic chamber without reflected echo, therefore the impact of the reflected echo must be included at the scene.
- The above performance data is obtained on the basis of the performance of this outdoor unit, with a 100%-combination of 4-way cassette type indoor units.

*1*2: For detailed information, please contact with Hisense technical engineers.

Hi-FLEXi S Heat Recovery (Standard)



HP		42HP	44HP	46HP	48HP	
Model	Model	AVWT-402FKFSB	AVWT-422FKFSB	AVWT-444FKFSB	AVWT-464FKFSB	
	Modules	AVWT-232FKFSB AVWT-170FKFSB	AVWT-232FKFSB AVWT-190FKFSB	AVWT-232FKFSB AVWT-212FKFSB	AVWT-232FKFSB AVWT-232FKFSB	
Power Supply		AC 3 ϕ , 380-415V/50/60Hz				
Cooling	Capacity	118.0	124.0	129.5	136.0	
	Capacity	kW				
	Capacity	kBtu/h	402.6	423.1	441.9	464.0
	Power Input	kW	50.23	53.25	56.56	59.64
EER	kW/kW	2.35	2.33	2.29	2.28	
Heating	Capacity (Max/Nom)	kW	131.0/118.0	138.0/124.0	144.0/129.5	150.0/136.0
	Capacity (Max/Nom)	kBtu/h	447.0/402.6	470.9/423.1	491.3/441.9	511.8/464.0
	Power Input (Max/Nom)	kW	42.57/35.63	44.33/37.10	47.39/39.67	50.27/41.84
COP (Max/Nom)	kW/kW	3.08/3.31	3.11/3.34	3.04/3.26	2.98/3.25	
Ventilation	Air Flow Rate	m ³ /min	550	617	700	700
	Fan Quantity		4	4	4	4
	Static Pressure	Pa	110	110	110	110
Sound Pressure Level (Normal/ Silent)	dB(A)	68/57	68/57	70/57	70/57	
Compressor	Type	Enhanced Vapor Injection Scroll Compressor				
	Compressor Quantity	pcs	4	4	4	4
Refrigerant	Type	R410A				
	Pre-charged Quantity	kg	20.70	21.30	23.00	23.00
Weight	Net Weight	kg	750	770	801	802
	Gross Weight	kg	820	843	877	878
Dimensions	External(HxWxD)	mm	1730x (1210+1600) x750	1730x (1350+1600) x750	1730x (1600+1600) x750	1730x (1600+1600) x750
		Packing(HxWxD)	mm	1950x (1275+1665) x790	1950x (1420+1665) x790	1950x (1665+1665) x790
	Cabinet Color		Ivory White			
		Low Pressure Gas Line	mm(in.)	ϕ 38.1(1-1/2)	ϕ 38.1(1-1/2)	ϕ 38.1(1-1/2)
Heat Recovery Operation System	High/Low Pressure Gas Line	mm(in.)	ϕ 31.75(1-1/4)	ϕ 31.75(1-1/4)	ϕ 31.75(1-1/4)	ϕ 31.75(1-1/4)
	Liquid Line	mm(in.)	ϕ 19.05(3/4)	ϕ 19.05(3/4)	ϕ 19.05(3/4)	ϕ 19.05(3/4)
	Gas Line	mm(in.)	ϕ 38.1(1-1/2)	ϕ 38.1(1-1/2)	ϕ 38.1(1-1/2)	ϕ 38.1(1-1/2)
Heat Pump Operation System	Gas Line	mm(in.)	ϕ 19.05(3/4)	ϕ 19.05(3/4)	ϕ 19.05(3/4)	ϕ 19.05(3/4)
	Liquid Line	mm(in.)	ϕ 19.05(3/4)	ϕ 19.05(3/4)	ϕ 19.05(3/4)	ϕ 19.05(3/4)
Connectable Indoor Units	Quantity	pcs	64	64	64	64
	Total Capacity	-	200%*1	200%*1	200%*1	200%*1
Piping Design	Height Difference Between ODU and IDU	m(above)	50(90*)	50(90*)	50(90*)	50(90*)
		m(below)	40(90*)	40(90*)	40(90*)	40(90*)
	Height Difference Between IDUs	m	15(30*)	15(30*)	15(30*)	15(30*)
		Max. Piping Length	m	165	165	165
Operation Range	Cooling	DB	-10°C-52°C	-10°C-52°C	-10°C-52°C	-10°C-52°C
	Heating	WB	-25°C-16.5°C	-25°C-16.5°C	-25°C-16.5°C	-25°C-16.5°C

Notes:

- Rated cooling capacity and rated heating capacity are tested in the following conditions:
Cooling conditions: indoor air inlet temperature: 27°C DB 19°C WB, outdoor air inlet temperature: 35°C DB, pipe length: 7.5m, pipe height difference: 0m.
Heating conditions: indoor air inlet temperature: 20°C DB, outdoor air inlet temperature: 7°C DB 6°C WB, pipe length: 7.5m, pipe height difference: 0m.
- The above noise values are measured in the anechoic chamber without reflected echo, therefore the impact of the reflected echo must be included at the scene.
- The above performance data is obtained on the basis of the performance of this outdoor unit, with a 100%-combination of 4-way cassette type indoor units.

*1*2: For detailed information, please contact with Hisense technical engineers.

Hi-FLEXi S Heat Recovery (Standard)



HP		50HP	52HP	54HP	56HP		
Model	Model	AVWT-478FKFSB	AVWT-494FKFSB	AVWT-510FKFSB	AVWT-530FKFSB		
	Modules	AVWT-170FKFSB	AVWT-170FKFSB	AVWT-170FKFSB	AVWT-190FKFSB		
		AVWT-154FKFSB	AVWT-170FKFSB	AVWT-170FKFSB	AVWT-170FKFSB		
Power Supply		AC 3Φ, 380-415V/50/60Hz					
Cooling	Capacity	140.0	145.0	150.0	156.0		
	Capacity	kW					
	kBtu/h	477.7	494.7	511.8	532.3		
	Power Input	kW	53.13	57.18	61.23	64.25	
Heating	EER	kW/kW	2.64	2.54	2.45	2.43	
	Capacity (Max/Nom)	kW	156.0/140.0	162.0/145.0	168.0/150.0	175.0/156.0	
	kBtu/h	532.3/477.7	552.7/494.7	573.2/511.8	597.1/532.3		
	Power Input (Max/Nom)	kW	48.82/40.65	50.56/42.39	52.29/44.14	54.06/45.60	
Ventilation	COP (Max/Nom)	kW/kW	3.20/3.44	3.20/3.42	3.21/3.40	3.24/3.42	
	Air Flow Rate	m ³ /min	600	600	600	667	
	Fan Quantity		6	6	6	6	
Sound Pressure Level	Static Pressure	Pa	110	110	110	110	
	(Normal/ Silent)	dB(A)	67/58	67/58	67/59	67/59	
Compressor	Type	Enhanced Vapor Injection Scroll Compressor					
	Compressor Quantity	pcs	4	5	6	6	
Refrigerant	Type	R410A					
	Pre-charged Quantity	kg	26.80	27.20	27.60	28.20	
	Net Weight	kg	929	988	1047	1067	
Weight	Gross Weight	kg	1025	1084	1143	1166	
	Dimensions	External(HxWxD)	mm	1730x (1210+1210+1210) x750	1730x (1210+1210+1210) x750	1730x (1210+1210+1210) x750	1730x (1210+1210+1350) x750
		Packing(HxWxD)	mm	1930x (1275+1275+1275) x790	1930x (1275+1275+1275) x790	1930x (1275+1275+1275) x790	1930x (1275+1275+1420) x790
Cabinet Color		Ivory White	Ivory White	Ivory White	Ivory White		
Heat Recovery Operation System	Low Pressure Gas Line	mm(in.)	Φ38.1(1-1/2)	Φ38.1(1-1/2)	Φ38.1(1-1/2)	Φ41.3(1-5/8)	
	High/Low Pressure Gas Line	mm(in.)	Φ31.75(1-1/4)	Φ31.75(1-1/4)	Φ31.75(1-1/4)	Φ38.1(1-1/2)	
	Liquid Line	mm(in.)	Φ19.05(3/4)	Φ19.05(3/4)	Φ19.05(3/4)	Φ22.2(7/8)	
Heat Pump Operation System	Gas Line	mm(in.)	Φ38.1(1-1/2)	Φ38.1(1-1/2)	Φ38.1(1-1/2)	Φ41.3(1-5/8)	
	Liquid Line	mm(in.)	Φ19.05(3/4)	Φ19.05(3/4)	Φ19.05(3/4)	Φ22.2(7/8)	
Connectable Indoor Units	Quantity	pcs	64	64	64	64	
	Total Capacity	-	200%*1	200%*1	200%*1	200%*1	
Piping Design	Height Difference Between ODU and IDU	m(above)	50(90*)	50(90*)	50(90*)	50(90*)	
	m(below)		40(90*)	40(90*)	40(90*)	40(90*)	
	Height Difference Between IDUs	m	15(30*)	15(30*)	15(30*)	15(30*)	
	Max. Piping Length	m	165	165	165	165	
Operation Range	Cooling	DB	-10°C-52°C	-10°C-52°C	-10°C-52°C	-10°C-52°C	
	Heating	WB	-25°C-16.5°C	-25°C-16.5°C	-25°C-16.5°C	-25°C-16.5°C	

Notes:

1. Rated cooling capacity and rated heating capacity are tested in the following conditions:

Cooling conditions: indoor air inlet temperature: 27°C DB 19°C WB, outdoor air inlet temperature: 35°C DB, pipe length: 7.5m, pipe height difference: 0m.

Heating conditions: indoor air inlet temperature: 20°C DB, outdoor air inlet temperature: 7°C DB 6°C WB, pipe length: 7.5m, pipe height difference: 0m.

2. The above noise values are measured in the anechoic chamber without reflected echo, therefore the impact of the reflected echo must be included at the scene.

3. The above performance data is obtained on the basis of the performance of this outdoor unit, with a 100%-combination of 4-way cassette type indoor units.

**2: For detailed information, please contact with Hisense technical engineers.

Hi-FLEXi S Heat Recovery (Standard)



HP		58HP	60HP	62HP	64HP		
Model	Model	AVWT-550FKFSB	AVWT-570FKFSB	AVWT-592FKFSB	AVWT-614FKFSB		
	Modules	AVWT-190FKFSB	AVWT-190FKFSB	AVWT-212FKFSB	AVWT-212FKFSB		
		AVWT-190FKFSB	AVWT-190FKFSB	AVWT-190FKFSB	AVWT-190FKFSB		
Power Supply		AC 3Φ, 380-415V/50/60Hz					
Cooling	Capacity	162.0	168.0	173.5	179.0		
	Capacity	kW					
	kBtu/h	552.7	573.2	592.0	610.7		
	Power Input	kW	67.27	70.29	73.60	76.91	
Heating	EER	kW/kW	2.41	2.39	2.36	2.33	
	Capacity (Max/Nom)	kW	182.0/162.0	189.0/168.0	195.0/173.5	201.0/179.0	
	kBtu/h	621.0/552.7	644.9/573.2	665.3/592.0	685.8/610.7		
	Power Input (Max/Nom)	kW	55.82/47.07	57.58/48.54	60.65/51.11	63.71/53.68	
Ventilation	COP (Max/Nom)	kW/kW	3.26/3.44	3.28/3.46	3.22/3.39	3.15/3.33	
	Air Flow Rate	m ³ /min	734	801	884	967	
	Fan Quantity		6	6	6	6	
Sound Pressure Level	Static Pressure	Pa	110	110	110	110	
	(Normal/ Silent)	dB(A)	67/59	68/59	70/59	71/59	
Compressor	Type	Enhanced Vapor Injection Scroll Compressor					
	Compressor Quantity	pcs	6	6	6	6	
Refrigerant	Type	R410A					
	Pre-charged Quantity	kg	28.80	29.40	31.10	32.80	
	Net Weight	kg	1087	1107	1138	1169	
Weight	Gross Weight	kg	1189	1212	1246	1280	
	Dimensions	External(HxWxD)	mm	1730x (1210+1350+1350) x750	1730x (1350+1350+1350) x750	1730x (1350+1350+1600) x750	1730x (1350+1600+1600) x750
		Packing(HxWxD)	mm	1930x (1275+1420+1420) x790	1930x (1420+1420+1420) x790	1930x (1420+1420+1665) x790	1930x (1420+1665+1665) x790
Cabinet Color		Ivory White	Ivory White	Ivory White	Ivory White		
Heat Recovery Operation System	Low Pressure Gas Line	mm(in.)	Φ44.5(1-3/4)	Φ44.5(1-3/4)	Φ44.5(1-3/4)	Φ44.5(1-3/4)	
	High/Low Pressure Gas Line	mm(in.)	Φ41.3(1-5/8)	Φ41.3(1-5/8)	Φ41.3(1-5/8)	Φ41.3(1-5/8)	
	Liquid Line	mm(in.)	Φ22.2(7/8)	Φ22.2(7/8)	Φ22.2(7/8)	Φ22.2(7/8)	
Heat Pump Operation System	Gas Line	mm(in.)	Φ44.5(1-3/4)	Φ44.5(1-3/4)	Φ44.5(1-3/4)	Φ44.5(1-3/4)	
	Liquid Line	mm(in.)	Φ22.2(7/8)	Φ22.2(7/8)	Φ22.2(7/8)	Φ22.2(7/8)	
Connectable Indoor Units	Quantity	pcs	64	64	64	64	
	Total Capacity	-	200%*1	200%*1	200%*1	200%*1	
Piping Design	Height Difference Between ODU and IDU	m(above)	50(90*)	50(90*)	50(90*)	50(90*)	
	m(below)		40(90*)	40(90*)	40(90*)	40(90*)	
	Height Difference Between IDUs	m	15(30*)	15(30*)	15(30*)	15(30*)	
	Max. Piping Length	m	165	165	165	165	
Operation Range	Cooling	DB	-10°C-52°C	-10°C-52°C	-10°C-52°C	-10°C-52°C	
	Heating	WB	-25°C-16.5°C	-25°C-16.5°C	-25°C-16.5°C	-25°C-16.5°C	

Notes:

1. Rated cooling capacity and rated heating capacity are tested in the following conditions:

Cooling conditions: indoor air inlet temperature: 27°C DB 19°C WB, outdoor air inlet temperature: 35°C DB, pipe length: 7.5m, pipe height difference: 0m.

Heating conditions: indoor air inlet temperature: 20°C DB, outdoor air inlet temperature: 7°C DB 6°C WB, pipe length: 7.5m, pipe height difference: 0m.

2. The above noise values are measured in the anechoic chamber without reflected echo, therefore the impact of the reflected echo must be included at the scene.

3. The above performance data is obtained on the basis of the performance of this outdoor unit, with a 100%-combination of 4-way cassette type indoor units.

**2: For detailed information, please contact with Hisense technical engineers.

Hi-FLEXi S Heat Recovery (Standard)



HP		66HP	68HP	70HP	72HP
Model	Model	AVWT-636FKFSB	AVWT-656FKFSB	AVWT-676FKFSB	AVWT-696FKFSB
	Modules	AVWT-212FKFSB	AVWT-232FKFSB	AVWT-232FKFSB	AVWT-232FKFSB
		AVWT-212FKFSB	AVWT-212FKFSB	AVWT-232FKFSB	AVWT-232FKFSB
Power Supply		AC 3Φ, 380-415V/50/60Hz			
Cooling	Capacity	184.5	191.0	197.5	204.0
	kW	629.5	651.7	673.9	696.0
	kBtu/h	80.22	83.30	86.38	89.46
	Power Input	2.30	2.29	2.29	2.28
EER					
Heating	Capacity (Max/Nom)	207.0/184.5	213.0/191.0	219.0/197.5	225.0/204.0
	kW	706.3/629.5	726.8/651.7	747.2/673.9	767.7/696.0
	kBtu/h	66.77/56.25	69.65/58.42	72.53/60.59	75.41/62.76
	Power Input (Max/Nom)	3.10/3.28	3.06/3.27	3.02/3.26	2.98/3.25
COP (Max/Nom)					
Ventilation	Air Flow Rate	1050	1050	1050	1050
	m³/min	6	6	6	6
	Fan Quantity	110	110	110	110
Static Pressure					
Pa	72/59	72/59	72/59	72/59	
Sound Pressure Level (Normal/ Silent)					
Compressor	Type	Enhanced Vapor Injection Scroll Compressor			
	Compressor Quantity	6	6	6	6
Refrigerant	Type	R410A			
	Pre-charged Quantity	34.50	34.50	34.50	34.50
	kg	1200	1201	1202	1203
Weight	Net Weight	1314	1315	1316	1317
	Gross Weight				
Dimensions	External(HxWxD)	1730x (1600+1600+1600)	1730x (1600+1600+1600)	1730x (1600+1600+1600)	1730x (1600+1600+1600)
	mm	x750	x750	x750	x750
	Packing(HxWxD)	1930x (1665+1665+1665)	1930x (1665+1665+1665)	1930x (1665+1665+1665)	1930x (1665+1665+1665)
	mm	x790	x790	x790	x790
Cabinet Color	Low Pressure Gas Line	mm(in.)	Φ44.5(1-3/4)	Φ50.8(2)	Φ50.8(2)
	High/Low Pressure Gas Line	mm(in.)	Φ41.3(1-5/8)	Φ44.5(1-3/4)	Φ44.5(1-3/4)
	Liquid Line	mm(in.)	Φ22.2(7/8)	Φ25.4(1)	Φ25.4(1)
	Gas Line	mm(in.)	Φ44.5(1-3/4)	Φ50.8(2)	Φ50.8(2)
Heat Pump Operation System	Liquid Line	mm(in.)	Φ22.2(7/8)	Φ25.4(1)	Φ25.4(1)
	Quantity	pcs	64	64	64
Connectable Indoor Units	Total Capacity	-	200%*1	200%*1	200%*1
	Height Difference Between ODU and IDU	m(above)	50(90*)	50(90*)	50(90*)
	m(below)	40(90*)	40(90*)	40(90*)	
	Height Difference Between IDUs	m	15(30*)	15(30*)	15(30*)
Piping Design	Max. Piping Length	m	165	165	165
	Cooling	DB	-10°C~52°C	-10°C~52°C	-10°C~52°C
Operation Range	Heating	WB	-25°C~16.5°C	-25°C~16.5°C	-25°C~16.5°C

Notes:
 1. Rated cooling capacity and rated heating capacity are tested in the following conditions:
 Cooling conditions: indoor air inlet temperature: 27°C DB 19°C WB, outdoor air inlet temperature: 35°C DB, pipe length: 7.5m, pipe height difference: 0m.
 Heating conditions: indoor air inlet temperature: 20°C DB, outdoor air inlet temperature: 7°C DB 6°C WB, pipe length: 7.5m, pipe height difference: 0m.
 2. The above noise values are measured in the anechoic chamber without reflected echo, therefore the impact of the reflected echo must be included at the scene.
 3. The above performance data is obtained on the basis of the performance of this outdoor unit, with a 100%-combination of 4-way cassette type indoor units.
 **2: For detailed information, please contact with Hisense technical engineers.

Hi-FLEXi S Heat Recovery (Standard)



HP		74HP	76HP	78HP	80HP
Model	Model	AVWT-700FKFSB	AVWT-720FKFSB	AVWT-740FKFSB	AVWT-760FKFSB
	Modules	AVWT-190FKFSB	AVWT-190FKFSB	AVWT-190FKFSB	AVWT-190FKFSB
		AVWT-170FKFSB	AVWT-170FKFSB	AVWT-190FKFSB	AVWT-190FKFSB
Power Supply		AC 3Φ, 380-415V/50/60Hz			
Cooling	Capacity	206.0	212.0	218.0	224.0
	kW	702.9	723.3	743.8	764.3
	kBtu/h	84.66	87.68	90.70	93.72
	Power Input	2.43	2.42	2.40	2.39
EER					
Heating	Capacity (Max/Nom)	231.0/206.0	238.0/212.0	245.0/218.0	252.0/224.0
	kW	788.2/702.9	812.1/723.3	835.9/743.8	859.8/764.3
	kBtu/h	71.49/60.32	73.25/61.78	75.01/63.25	76.78/64.72
	Power Input (Max/Nom)	3.23/3.42	3.25/3.43	3.27/3.45	3.28/3.46
COP (Max/Nom)					
Ventilation	Air Flow Rate	867	934	1001	1068
	m³/min	8	8	8	8
	Fan Quantity	110	110	110	110
Static Pressure					
Pa	69/60	69/60	69/60	69/60	
Sound Pressure Level (Normal/ Silent)					
Compressor	Type	Enhanced Vapor Injection Scroll Compressor			
	Compressor Quantity	8	8	8	8
Refrigerant	Type	R410A			
	Pre-charged Quantity	37.40	38.00	38.60	39.20
	kg	1416	1436	1456	1476
Weight	Net Weight	1547	1570	1593	1616
	Gross Weight				
Dimensions	External(HxWxD)	1730x (1210+1210+1210+1350)	1730x (1210+1210+1350+1350)	1730x (1210+1350+1350+1350)	1730x (1350+1350+1350+1350)
	mm	x750	x750	x750	x750
	Packing(HxWxD)	1930x (1275+1275+1275+1420)	1930x (1275+1275+1420+1420)	1930x (1275+1420+1420+1420)	1930x (1420+1420+1420+1420)
	mm	x790	x790	x790	x790
Cabinet Color	Low Pressure Gas Line	mm(in.)	Φ50.8(2)	Φ50.8(2)	Φ50.8(2)
	High/Low Pressure Gas Line	mm(in.)	Φ44.5(1-3/4)	Φ44.5(1-3/4)	Φ44.5(1-3/4)
	Liquid Line	mm(in.)	Φ25.4(1)	Φ25.4(1)	Φ25.4(1)
	Gas Line	mm(in.)	Φ50.8(2)	Φ50.8(2)	Φ50.8(2)
Heat Pump Operation System	Liquid Line	mm(in.)	Φ25.4(1)	Φ25.4(1)	Φ25.4(1)
	Quantity	pcs	64	64	64
Connectable Indoor Units	Total Capacity	-	200%*1	200%*1	200%*1
	Height Difference Between ODU and IDU	m(above)	50(90*)	50(90*)	50(90*)
	m(below)	40(90*)	40(90*)	40(90*)	
	Height Difference Between IDUs	m	15(30*)	15(30*)	15(30*)
Piping Design	Max. Piping Length	m	165	165	165
	Cooling	DB	-10°C~52°C	-10°C~52°C	-10°C~52°C
Operation Range	Heating	WB	-25°C~16.5°C	-25°C~16.5°C	-25°C~16.5°C

Notes:
 1. Rated cooling capacity and rated heating capacity are tested in the following conditions:
 Cooling conditions: indoor air inlet temperature: 27°C DB 19°C WB, outdoor air inlet temperature: 35°C DB, pipe length: 7.5m, pipe height difference: 0m.
 Heating conditions: indoor air inlet temperature: 20°C DB, outdoor air inlet temperature: 7°C DB 6°C WB, pipe length: 7.5m, pipe height difference: 0m.
 2. The above noise values are measured in the anechoic chamber without reflected echo, therefore the impact of the reflected echo must be included at the scene.
 3. The above performance data is obtained on the basis of the performance of this outdoor unit, with a 100%-combination of 4-way cassette type indoor units.
 **2: For detailed information, please contact with Hisense technical engineers.

Hi-FLEXi S Heat Recovery (Standard)



HP		82HP	84HP	86HP	88HP	
Model	Model	AVWT-782FKFSB	AVWT-804FKFSB	AVWT-826FKFSB	AVWT-848FKFSB	
	Modules	AVWT-212FKFSB	AVWT-212FKFSB	AVWT-212FKFSB	AVWT-212FKFSB	
		AVWT-190FKFSB	AVWT-212FKFSB	AVWT-212FKFSB	AVWT-212FKFSB	
		AVWT-190FKFSB	AVWT-190FKFSB	AVWT-212FKFSB	AVWT-212FKFSB	
Power Supply		AC 3 ϕ , 380-415V/50/60Hz				
Cooling	Capacity	229.5	235.0	240.5	246.0	
	kW					
	kBtu/h	783.1	801.8	820.6	839.4	
	Power Input	97.03	100.34	103.65	106.96	
EER	2.37	2.34	2.32	2.30		
Heating	Capacity (Max/Nom)	258.0/229.5	264.0/235.0	270.0/240.5	276.0/246.0	
	kW					
	kBtu/h	880.3/783.1	900.8/801.8	921.2/820.6	941.7/839.4	
	Power Input (Max/Nom)	79.84/67.29	82.90/69.86	85.97/72.43	89.03/75.00	
COP (Max/Nom)	3.23/3.41	3.18/3.36	3.14/3.32	3.10/3.28		
Ventilation	Air Flow Rate	1151	1234	1317	1400	
	m ³ /min					
	Fan Quantity	8	8	8	8	
Static Pressure	Pa	110	110	110	110	
Sound Pressure Level (Normal/ Silent)	dB(A)	70/60	71/60	72/60	73/60	
Compressor	Type	Enhanced Vapor Injection Scroll Compressor				
	Compressor Quantity	8	8	8	8	
Refrigerant	Type	R410A				
	Pre-charged Quantity	40.90	42.60	44.30	46.00	
Weight	Net Weight	1507	1538	1569	1600	
	Gross Weight	1650	1684	1718	1752	
Dimensions	External(HxWxD)	mm	1730x (1350+1350+1350+1600) x750	1730x (1350+1350+1600+1600) x750	1730x (1350+1600+1600+1600) x750	1730x (1600+1600+1600+1600) x750
		Packing(HxWxD)	mm	1950x (1420+1420+1420+1665) x790	1950x (1420+1420+1665+1665) x790	1950x (1420+1665+1665+1665) x790
	Cabinet Color	Ivory White				
		Heat Recovery Operation System	Low Pressure Gas Line	mm(in.)	ϕ 50.8(2)	ϕ 50.8(2)
High/Low Pressure Gas Line	mm(in.)	ϕ 44.5(1-3/4)	ϕ 44.5(1-3/4)	ϕ 44.5(1-3/4)	ϕ 44.5(1-3/4)	ϕ 44.5(1-3/4)
Liquid Line	mm(in.)	ϕ 25.4(1)	ϕ 25.4(1)	ϕ 25.4(1)	ϕ 25.4(1)	ϕ 25.4(1)
Heat Pump Operation System	Gas Line	mm(in.)	ϕ 50.8(2)	ϕ 50.8(2)	ϕ 50.8(2)	ϕ 50.8(2)
	Liquid Line	mm(in.)	ϕ 25.4(1)	ϕ 25.4(1)	ϕ 25.4(1)	ϕ 25.4(1)
Connectable Indoor Units	Quantity	64	64	64	64	
	Total Capacity	200%*1	200%*1	200%*1	200%*1	
Piping Design	Height Difference Between ODU and IDU	m(above)	50(90*)	50(90*)	50(90*)	50(90*)
		m(below)	40(90*)	40(90*)	40(90*)	40(90*)
	Height Difference Between IDUs	m	15(30*)	15(30*)	15(30*)	15(30*)
	Max. Piping Length	m	165	165	165	165
Operation Range	Cooling	DB	-10 $^{\circ}$ C-52 $^{\circ}$ C	-10 $^{\circ}$ C-52 $^{\circ}$ C	-10 $^{\circ}$ C-52 $^{\circ}$ C	-10 $^{\circ}$ C-52 $^{\circ}$ C
	Heating	WB	-25 $^{\circ}$ C-16.5 $^{\circ}$ C	-25 $^{\circ}$ C-16.5 $^{\circ}$ C	-25 $^{\circ}$ C-16.5 $^{\circ}$ C	-25 $^{\circ}$ C-16.5 $^{\circ}$ C

Notes:

1. Rated cooling capacity and rated heating capacity are tested in the following conditions:

Cooling conditions: indoor air inlet temperature: 27 $^{\circ}$ C DB 19 $^{\circ}$ C WB, outdoor air inlet temperature: 35 $^{\circ}$ C DB, pipe length: 7.5m, pipe height difference: 0m.Heating conditions: indoor air inlet temperature: 20 $^{\circ}$ C DB, outdoor air inlet temperature: 7 $^{\circ}$ C DB 6 $^{\circ}$ C WB, pipe length: 7.5m, pipe height difference: 0m.

2. The above noise values are measured in the anechoic chamber without reflected echo, therefore the impact of the reflected echo must be included at the scene.

3. The above performance data is obtained on the basis of the performance of this outdoor unit, with a 100%-combination of 4-way cassette type indoor units.

**2: For detailed information, please contact with Hisense technical engineers.

Hi-FLEXi S Heat Recovery (Standard)



HP		90HP	92HP	94HP	96HP	
Model	Model	AVWT-868FKFSB	AVWT-888FKFSB	AVWT-908FKFSB	AVWT-928FKFSB	
	Modules	AVWT-232FKFSB	AVWT-232FKFSB	AVWT-232FKFSB	AVWT-232FKFSB	
		AVWT-212FKFSB	AVWT-232FKFSB	AVWT-232FKFSB	AVWT-232FKFSB	
		AVWT-212FKFSB	AVWT-212FKFSB	AVWT-232FKFSB	AVWT-232FKFSB	
Power Supply		AC 3 ϕ , 380-415V/50/60Hz				
Cooling	Capacity	252.5	259.0	265.5	272.0	
	kW					
	kBtu/h	861.5	883.7	905.9	928.1	
	Power Input	110.04	113.12	116.20	119.28	
EER	2.29	2.29	2.28	2.28		
Heating	Capacity (Max/Nom)	282.0/252.5	288.0/259.0	294.0/265.5	300.0/272.0	
	kW					
	kBtu/h	962.2/861.5	982.7/883.7	1003.1/905.9	1023.6/928.1	
	Power Input (Max/Nom)	91.91/77.17	94.79/79.34	97.66/81.51	100.54/83.68	
COP (Max/Nom)	3.07/3.27	3.04/3.26	3.01/3.26	2.98/3.25		
Ventilation	Air Flow Rate	1400	1400	1400	1400	
	m ³ /min					
	Fan Quantity	8	8	8	8	
Static Pressure	Pa	110	110	110	110	
Sound Pressure Level (Normal/ Silent)	dB(A)	73/60	73/60	73/60	73/60	
Compressor	Type	Enhanced Vapor Injection Scroll Compressor				
	Compressor Quantity	8	8	8	8	
Refrigerant	Type	R410A				
	Pre-charged Quantity	46.00	46.00	46.00	46.00	
Weight	Net Weight	1601	1602	1603	1604	
	Gross Weight	1753	1754	1755	1756	
Dimensions	External(HxWxD)	mm	1730x (1600+1600+1600+1600) x750	1730x (1600+1600+1600+1600) x750	1730x (1600+1600+1600+1600) x750	1730x (1600+1600+1600+1600) x750
		Packing(HxWxD)	mm	1950x (1665+1665+1665+1665) x790	1950x (1665+1665+1665+1665) x790	1950x (1665+1665+1665+1665) x790
	Cabinet Color	Ivory White				
		Heat Recovery Operation System	Low Pressure Gas Line	mm(in.)	ϕ 50.8(2)	ϕ 50.8(2)
High/Low Pressure Gas Line	mm(in.)	ϕ 44.5(1-3/4)	ϕ 44.5(1-3/4)	ϕ 44.5(1-3/4)	ϕ 44.5(1-3/4)	
Liquid Line	mm(in.)	ϕ 25.4(1)	ϕ 25.4(1)	ϕ 25.4(1)	ϕ 25.4(1)	
Heat Pump Operation System	Gas Line	mm(in.)	ϕ 50.8(2)	ϕ 50.8(2)	ϕ 50.8(2)	
	Liquid Line	mm(in.)	ϕ 25.4(1)	ϕ 25.4(1)	ϕ 25.4(1)	
Connectable Indoor Units	Quantity	64	64	64	64	
	Total Capacity	200%*1	200%*1	200%*1	200%*1	
Piping Design	Height Difference Between ODU and IDU	m(above)	50(90*)	50(90*)	50(90*)	50(90*)
		m(below)	40(90*)	40(90*)	40(90*)	40(90*)
	Height Difference Between IDUs	m	15(30*)	15(30*)	15(30*)	15(30*)
	Max. Piping Length	m	165	165	165	165
Operation Range	Cooling	DB	-10 $^{\circ}$ C-52 $^{\circ}$ C	-10 $^{\circ}$ C-52 $^{\circ}$ C	-10 $^{\circ}$ C-52 $^{\circ}$ C	-10 $^{\circ}$ C-52 $^{\circ}$ C
	Heating	WB	-25 $^{\circ}$ C-16.5 $^{\circ}$ C	-25 $^{\circ}$ C-16.5 $^{\circ}$ C	-25 $^{\circ}$ C-16.5 $^{\circ}$ C	-25 $^{\circ}$ C-16.5 $^{\circ}$ C

Notes:

1. Rated cooling capacity and rated heating capacity are tested in the following conditions:

Cooling conditions: indoor air inlet temperature: 27 $^{\circ}$ C DB 19 $^{\circ}$ C WB, outdoor air inlet temperature: 35 $^{\circ}$ C DB, pipe length: 7.5m, pipe height difference: 0m.Heating conditions: indoor air inlet temperature: 20 $^{\circ}$ C DB, outdoor air inlet temperature: 7 $^{\circ}$ C DB 6 $^{\circ}$ C WB, pipe length: 7.5m, pipe height difference: 0m.

2. The above noise values are measured in the anechoic chamber without reflected echo, therefore the impact of the reflected echo must be included at the scene.

3. The above performance data is obtained on the basis of the performance of this outdoor unit, with a 100%-combination of 4-way cassette type indoor units.

**2: For detailed information, please contact with Hisense technical engineers.

Hi-FLEXi S Heat Recovery (High Efficiency)



		HP	8HP	10HP	12HP	14HP	
Model		Model	AVWT-76FKFSHA	AVWT-96FKFSHA	AVWT-114FKFSHA	AVWT-136FKFSHA	
Model		Modules	—	—	—	—	
Power Supply			AC 3Φ, 380-415V/50/60Hz				
Cooling	Capacity	kW	22.4	28.0	33.5	40.0	
		kBtu/h	76.4	95.5	114.3	136.5	
	Power Input	kW	4.77	6.67	7.25	8.70	
	EER	kW/kW	4.70	4.20	4.62	4.60	
	SEER	kW/kW	8.67	7.87	8.56	8.36	
Heating	Capacity (Max/Nom)	kW	25.0/22.4	31.5/28.0	37.5/33.5	45.0/40.0	
		kBtu/h	85.3/76.4	107.5/95.5	128.0/114.3	153.5/136.5	
	Power Input (Max/Nom)	kW	4.88/4.06	6.29/5.18	7.50/6.20	10.47/8.70	
	COP (Max/Nom)	kW/kW	5.12/5.52	5.01/5.41	5.00/5.40	4.30/4.60	
	SCOP	kW/kW	4.11	4.21	4.24	3.88	
Ventilation	Air Flow Rate	m ³ /min	183	183	200	200	
	Fan Quantity		1	1	2	2	
Sound Pressure Level (Normal/ Silent)	Static Pressure	Pa	110	110	110	110	
			59/49	60/49	62/51	62/53	
Compressor	Type	—	Enhanced Vapor Injection Scroll Compressor				
	Compressor Quantity	pcs	1	1	1	2	
Refrigerant	Type	—	R410A				
	Pre-charged Quantity	kg	6.00	6.00	8.80	9.20	
Weight	Net Weight	kg	246	247	290	353	
	Gross Weight	kg	276	277	322	385	
Dimensions	External(HxWxD)	mm	1730x950x750	1730x950x750	1730x1210x750	1730x1210x750	
	Packing(HxWxD)	mm	1950x1015x790	1950x1015x790	1950x1275x790	1950x1275x790	
Cabinet Color			Ivory White	Ivory White	Ivory White	Ivory White	
	Heat Recovery Operation System	Low Pressure Gas Line	mm(in.)	φ19.05(3/4)	φ22.20(7/8)	φ25.40(1)	φ25.40(1)
Heat Recovery Operation System		High/Low Pressure Gas Line	mm(in.)	φ15.88(5/8)	φ19.05(3/4)	φ22.2(7/8)	φ22.2(7/8)
		Liquid Line	mm(in.)	φ9.53(3/8)	φ9.53(3/8)	φ12.70(1/2)	φ12.70(1/2)
	Heat Pump Operation System	Gas Line	mm(in.)	φ19.05(3/4)	φ22.20(7/8)	φ25.40(1)	φ25.40(1)
Heat Pump Operation System		Liquid Line	mm(in.)	φ9.53(3/8)	φ9.53(3/8)	φ12.70(1/2)	φ12.70(1/2)
	Connectable Indoor Units	Quantity	pcs	13	16	19	23
		Total Capacity	—	200%*1	200%*1	200%*1	200%*1
Piping Design	Height Difference Between ODU and IDU	m(above)	50(90*2)	50(90*2)	50(90*2)	50(90*2)	
		m(below)	40(90*2)	40(90*2)	40(90*2)	40(90*2)	
	Height Difference Between IDUs	m	15(30*2)	15(30*2)	15(30*2)	15(30*2)	
		Max. Piping Length	m	165	165	165	165
Operation Range	Cooling	DB	-10°C-52°C	-10°C-52°C	-10°C-52°C	-10°C-52°C	
	Heating	WB	-25°C-16.5°C	-25°C-16.5°C	-25°C-16.5°C	-25°C-16.5°C	

Notes:
 1. Rated cooling capacity and rated heating capacity are tested in the following conditions:
 Cooling conditions: indoor air inlet temperature: 27°C DB 19°C WB, outdoor air inlet temperature: 35°C DB, pipe length: 7.5m, pipe height difference: 0m.
 Heating conditions: indoor air inlet temperature: 20°C DB, outdoor air inlet temperature: 7°C DB 6°C WB, pipe length: 7.5m, pipe height difference: 0m.
 2. The above noise values are measured in the anechoic chamber without reflected echo, therefore the impact of the reflected echo must be included at the scene.
 3. The above performance data is obtained on the basis of the performance of this outdoor unit, with a 100%-combination of 4-way cassette type indoor units.
 **2: For detailed information, please contact with Hisense technical engineers.

Hi-FLEXi S Heat Recovery (High Efficiency)



		HP	16HP	18HP	20HP	22HP	
Model		Model	AVWT-154FKFSHA	AVWT-170FKFSHA	AVWT-190FKFSHA	AVWT-212FKFSHA	
Model		Modules	—	—	—	—	
Power Supply			AC 3Φ, 380-415V/50/60Hz				
Cooling	Capacity	kW	45.0	50.0	56.0	61.5	
		kBtu/h	153.5	170.6	191.1	209.8	
	Power Input	kW	11.22	12.69	14.36	18.41	
	EER	kW/kW	4.01	3.94	3.90	3.34	
	SEER	kW/kW	7.98	8.03	7.72	7.53	
Heating	Capacity (Max/Nom)	kW	50.0/45.0	56.0/50.0	63.0/56.0	69.0/61.5	
		kBtu/h	170.6/153.5	191.1/170.6	215.0/191.1	235.4/209.8	
	Power Input (Max/Nom)	kW	11.88/10.23	13.97/11.88	15.75/13.40	20.18/16.49	
	COP (Max/Nom)	kW/kW	4.21/4.40	4.01/4.21	4.00/4.18	3.42/3.73	
	SCOP	kW/kW	3.85	4.10	4.08	4.03	
Ventilation	Air Flow Rate	m ³ /min	267	298	350	350	
	Fan Quantity		2	2	2	2	
Sound Pressure Level (Normal/ Silent)	Static Pressure	Pa	110	110	110	110	
			62/54	62/55	63/52	64/52	
Compressor	Type	—	Enhanced Vapor Injection Scroll Compressor				
	Compressor Quantity	pcs	2	2	2	2	
Refrigerant	Type	—	R410A				
	Pre-charged Quantity	kg	9.80	10.60	11.50	11.50	
Weight	Net Weight	kg	373	378	401	402	
	Gross Weight	kg	408	413	439	440	
Dimensions	External(HxWxD)	mm	1730x1350x750	1730x1350x750	1730 × 1600 × 750	1730 × 1600 × 750	
	Packing(HxWxD)	mm	1950x1420x790	1950x1420x790	1950 × 1665 × 790	1950 × 1665 × 790	
Cabinet Color			Ivory White	Ivory White	Ivory White	Ivory White	
	Heat Recovery Operation System	Low Pressure Gas Line	mm(in.)	φ28.60(1-1/8)	φ28.60(1-1/8)	φ28.60(1-1/8)	φ28.60(1-1/8)
Heat Recovery Operation System		High/Low Pressure Gas Line	mm(in.)	φ22.2(7/8)	φ22.2(7/8)	φ25.4(1)	φ25.4(1)
		Liquid Line	mm(in.)	φ12.70(1/2)	φ15.88(5/8)	φ15.88(5/8)	φ15.88(5/8)
	Heat Pump Operation System	Gas Line	mm(in.)	φ28.60(1-1/8)	φ28.60(1-1/8)	φ28.60(1-1/8)	φ28.60(1-1/8)
Heat Pump Operation System		Liquid Line	mm(in.)	φ12.70(1/2)	φ15.88(5/8)	φ15.88(5/8)	φ15.88(5/8)
	Connectable Indoor Units	Quantity	pcs	26	29	33	36
		Total Capacity	—	200%*1	200%*1	200%*1	200%*1
Piping Design	Height Difference Between ODU and IDU	m(above)	50(90*2)	50(90*2)	50(90*2)	50(90*2)	
		m(below)	40(90*2)	40(90*2)	40(90*2)	40(90*2)	
	Height Difference Between IDUs	m	15(30*2)	15(30*2)	15(30*2)	15(30*2)	
		Max. Piping Length	m	165	165	165	165
Operation Range	Cooling	DB	-10°C-52°C	-10°C-52°C	-10°C-52°C	-10°C-52°C	
	Heating	WB	-25°C-16.5°C	-25°C-16.5°C	-25°C-16.5°C	-25°C-16.5°C	

Notes:
 1. Rated cooling capacity and rated heating capacity are tested in the following conditions:
 Cooling conditions: indoor air inlet temperature: 27°C DB 19°C WB, outdoor air inlet temperature: 35°C DB, pipe length: 7.5m, pipe height difference: 0m.
 Heating conditions: indoor air inlet temperature: 20°C DB, outdoor air inlet temperature: 7°C DB 6°C WB, pipe length: 7.5m, pipe height difference: 0m.
 2. The above noise values are measured in the anechoic chamber without reflected echo, therefore the impact of the reflected echo must be included at the scene.
 3. The above performance data is obtained on the basis of the performance of this outdoor unit, with a 100%-combination of 4-way cassette type indoor units.
 **2: For detailed information, please contact with Hisense technical engineers.

Hi-FLEXi S Heat Recovery (High Efficiency)



HP		24HP	26HP	28HP	30HP
Model	Model	AVWT-228FKFSHA	AVWT-250FKFSHA	AVWT-272FKFSHA	AVWT-290FKFSHA
	Modules	AVWT-114FKFSHA AVWT-114FKFSHA	AVWT-136FKFSHA AVWT-114FKFSHA	AVWT-136FKFSHA AVWT-136FKFSHA	AVWT-154FKFSHA AVWT-136FKFSHA
Power Supply		AC 3 ϕ , 380-415V/50/60Hz			
Cooling	Capacity	kW 67.0	73.5	80.0	85.0
		kBtu/h 228.6	250.8	273.0	290.0
	Power Input	kW 14.50	15.95	17.40	19.92
	EER	kW/kW 4.62	4.61	4.60	4.27
Heating	Capacity (Max/Nom)	kW 75.0/67.0	82.5/73.5	90.0/80.0	95.0/85.0
		kBtu/h 255.9/228.6	281.5/250.8	307.1/273.0	324.1/290.0
	Power Input (Max/Nom)	kW 15.00/12.40	17.97/14.90	20.94/17.40	22.35/18.93
	COP (Max/Nom)	kW/kW 5.00/5.40	4.59/4.93	4.30/4.60	4.25/4.49
Ventilation	Air Flow Rate	m ³ /min 400	400	400	467
	Fan Quantity	4	4	4	4
	Static Pressure	Pa 110	110	110	110
Sound Pressure Level (Normal/ Silent)		65/54	65/55	65/56	65/57
Compressor	Type	Enhanced Vapor Injection Scroll Compressor			
	Compressor Quantity	pcs 2	3	4	4
Refrigerant	Type	R410A			
	Pre-charged Quantity	kg 17.60	18.00	18.40	19.00
Weight	Net Weight	kg 580	643	706	726
	Gross Weight	kg 644	707	770	793
Dimensions	External(HxWxD)	mm 1730x (1210+1210) x750	1730x (1210+1210) x750	1730x (1210+1210) x750	1730x (1210+1350) x750
		mm 1950x (1275+1275) x790	1950x (1275+1275) x790	1950x (1275+1275) x790	1950x (1275+1420) x790
	Packing(HxWxD)	mm (1275+1275) x790	(1275+1275) x790	(1275+1275) x790	(1275+1420) x790
Cabinet Color		Ivory White			
Heat Recovery Operation System	Low Pressure Gas Line	mm(in.) ϕ 28.60(1-1/8)	ϕ 31.75(1-1/4)	ϕ 31.75(1-1/4)	ϕ 31.75(1-1/4)
	High/Low Pressure Gas Line	mm(in.) ϕ 25.4(1)	ϕ 25.4(1)	ϕ 28.6(1-1/8)	ϕ 28.6(1-1/8)
	Liquid Line	mm(in.) ϕ 15.88(5/8)	ϕ 19.05(3/4)	ϕ 19.05(3/4)	ϕ 19.05(3/4)
Heat Pump Operation System	Gas Line	mm(in.) ϕ 28.60(1-1/8)	ϕ 31.75(1-1/4)	ϕ 31.75(1-1/4)	ϕ 31.75(1-1/4)
	Liquid Line	mm(in.) ϕ 15.88(5/8)	ϕ 19.05(3/4)	ϕ 19.05(3/4)	ϕ 19.05(3/4)
Connectable Indoor Units	Quantity	pcs 40	43	47	50
	Total Capacity	- 200%*1	200%*1	200%*1	200%*1
Piping Design	Height Difference Between ODU and IDU	m(above) 50(90*2)	50(90*2)	50(90*2)	50(90*2)
		m(below) 40(90*2)	40(90*2)	40(90*2)	40(90*2)
	Height Difference Between IDUs	m 15(30*2)	15(30*2)	15(30*2)	15(30*2)
	Max. Piping Length	m 165	165	165	165
Operation Range	Cooling	DB -10°C~52°C	-10°C~52°C	-10°C~52°C	-10°C~52°C
	Heating	WB -25°C~16.5°C	-25°C~16.5°C	-25°C~16.5°C	-25°C~16.5°C

Notes:

1. Rated cooling capacity and rated heating capacity are tested in the following conditions:

Cooling conditions: indoor air inlet temperature: 27°C DB 19°C WB, outdoor air inlet temperature: 35°C DB, pipe length: 7.5m, pipe height difference: 0m.

Heating conditions: indoor air inlet temperature: 20°C DB, outdoor air inlet temperature: 7°C DB 6°C WB, pipe length: 7.5m, pipe height difference: 0m.

2. The above noise values are measured in the anechoic chamber without reflected echo, therefore the impact of the reflected echo must be included at the scene.

3. The above performance data is obtained on the basis of the performance of this outdoor unit, with a 100%-combination of 4-way cassette type indoor units.

**12: For detailed information, please contact with Hisense technical engineers.

Hi-FLEXi S Heat Recovery (High Efficiency)



HP		32HP	34HP	36HP	38HP
Model	Model	AVWT-308FKFSHA	AVWT-324FKFSHA	AVWT-340FKFSHA	AVWT-360FKFSHA
	Modules	AVWT-154FKFSHA AVWT-154FKFSHA	AVWT-170FKFSHA AVWT-154FKFSHA	AVWT-170FKFSHA AVWT-170FKFSHA	AVWT-190FKFSHA AVWT-170FKFSHA
Power Supply		AC 3 ϕ , 380-415V/50/60Hz			
Cooling	Capacity	kW 90.0	95.0	100.0	106.0
		kBtu/h 307.1	324.1	341.2	361.7
	Power Input	kW 22.44	23.91	25.38	27.05
	EER	kW/kW 4.01	3.97	3.94	3.92
Heating	Capacity (Max/Nom)	kW 100.0/90.0	106.0/95.0	112.0/100.0	119.0/106.0
		kBtu/h 341.2/307.1	361.7/324.1	382.1/341.2	406.0/361.7
	Power Input (Max/Nom)	kW 23.76/20.46	25.85/22.11	27.94/23.76	29.72/25.28
	COP (Max/Nom)	kW/kW 4.21/4.40	4.10/4.30	4.01/4.21	4.00/4.19
Ventilation	Air Flow Rate	m ³ /min 534	565	596	648
	Fan Quantity	4	4	4	4
	Static Pressure	Pa 110	110	110	110
Sound Pressure Level (Normal/ Silent)		65/57	65/58	65/58	66/57
Compressor	Type	Enhanced Vapor Injection Scroll Compressor			
	Compressor Quantity	pcs 4	4	4	4
Refrigerant	Type	R410A			
	Pre-charged Quantity	kg 19.60	20.40	21.20	22.10
Weight	Net Weight	kg 746	751	756	779
	Gross Weight	kg 816	821	826	852
Dimensions	External(HxWxD)	mm 1730x (1350+1350) x750	1730x (1350+1350) x750	1730x (1350+1350) x750	1730x (1350+1600) x750
		mm 1950x (1420+1420) x790	1950x (1420+1420) x790	1950x (1420+1420) x790	1950x (1420+1665) x790
	Packing(HxWxD)	mm (1420+1420) x790	(1420+1420) x790	(1420+1420) x790	(1420+1665) x790
Cabinet Color		Ivory White			
Heat Recovery Operation System	Low Pressure Gas Line	mm(in.) ϕ 31.75(1-1/4)	ϕ 31.75(1-1/4)	ϕ 38.1(1-1/2)	ϕ 38.1(1-1/2)
	High/Low Pressure Gas Line	mm(in.) ϕ 28.6(1-1/8)	ϕ 28.6(1-1/8)	ϕ 28.6(1-1/8)	ϕ 31.75(1-1/4)
	Liquid Line	mm(in.) ϕ 19.05(3/4)	ϕ 19.05(3/4)	ϕ 19.05(3/4)	ϕ 19.05(3/4)
Heat Pump Operation System	Gas Line	mm(in.) ϕ 31.75(1-1/4)	ϕ 31.75(1-1/4)	ϕ 38.1(1-1/2)	ϕ 38.1(1-1/2)
	Liquid Line	mm(in.) ϕ 19.05(3/4)	ϕ 19.05(3/4)	ϕ 19.05(3/4)	ϕ 19.05(3/4)
Connectable Indoor Units	Quantity	pcs 53	56	59	64
	Total Capacity	- 200%*1	200%*1	200%*1	200%*1
Piping Design	Height Difference Between ODU and IDU	m(above) 50(90*2)	50(90*2)	50(90*2)	50(90*2)
		m(below) 40(90*2)	40(90*2)	40(90*2)	40(90*2)
	Height Difference Between IDUs	m 15(30*2)	15(30*2)	15(30*2)	15(30*2)
	Max. Piping Length	m 165	165	165	165
Operation Range	Cooling	DB -10°C~52°C	-10°C~52°C	-10°C~52°C	-10°C~52°C
	Heating	WB -25°C~16.5°C	-25°C~16.5°C	-25°C~16.5°C	-25°C~16.5°C

Notes:

1. Rated cooling capacity and rated heating capacity are tested in the following conditions:

Cooling conditions: indoor air inlet temperature: 27°C DB 19°C WB, outdoor air inlet temperature: 35°C DB, pipe length: 7.5m, pipe height difference: 0m.

Heating conditions: indoor air inlet temperature: 20°C DB, outdoor air inlet temperature: 7°C DB 6°C WB, pipe length: 7.5m, pipe height difference: 0m.

2. The above noise values are measured in the anechoic chamber without reflected echo, therefore the impact of the reflected echo must be included at the scene.

3. The above performance data is obtained on the basis of the performance of this outdoor unit, with a 100%-combination of 4-way cassette type indoor units.

**12: For detailed information, please contact with Hisense technical engineers.

Hi-FLEXi S Heat Recovery (High Efficiency)



HP		40HP	42HP	44HP
Model		AVWT-380FKFSHA	AVWT-402FKFSHA	AVWT-424FKFSHA
Model	Modules	AVWT-190FKFSHA AVWT-190FKFSHA	AVWT-212FKFSHA AVWT-190FKFSHA	AVWT-212FKFSHA AVWT-212FKFSHA
	Power Supply	AC 3 ϕ , 380-415V/50/60Hz		
Cooling	Capacity	kW 112.0	117.5	123.0
		kBtu/h 382.1	400.9	419.7
	Power Input	kW 28.72	32.77	36.82
	EER	kW/kW 3.90	3.59	3.34
Heating	Capacity (Max/Nom)	kW 126.0/112.0	132.0/117.5	138.0/123.0
		kBtu/h 429.9/382.1	450.4/400.9	470.9/419.7
	Power Input (Max/Nom)	kW 31.50/26.80	35.93/29.89	40.36/32.98
	COP (Max/Nom)	kW/kW 4.00/4.18	3.67/3.93	3.42/3.73
Ventilation	Air Flow Rate	m ³ /min 700	700	700
	Fan Quantity	4	4	4
	Static Pressure	Pa 110	110	110
Sound Pressure Level (Normal/ Silent)	dB(A)	66/55	67/55	67/55
Compressor	Type	Enhanced Vapor Injection Scroll Compressor		
	Compressor Quantity	pcs 4	4	4
Refrigerant	Type	R410A		
	Pre-charged Quantity	kg 23.00	23.00	23.00
	Net Weight	kg 802	803	804
Weight	Gross Weight	kg 878	879	880
	Dimensions	External(HxWxD)	mm 1730x (1600+1600) x750	1730x (1600+1600) x750
Packing(HxWxD)		mm 1950x (1665+1665) x790	1950x (1665+1665) x790	1950x (1665+1665) x790
Cabinet Color		Ivory White	Ivory White	Ivory White
Heat Recovery Operation System	Low Pressure Gas Line	mm(in.) ϕ 38.1(1-1/2)	ϕ 38.1(1-1/2)	ϕ 38.1(1-1/2)
	High/Low Pressure Gas Line	mm(in.) ϕ 31.75(1-1/4)	ϕ 31.75(1-1/4)	ϕ 31.75(1-1/4)
	Liquid Line	mm(in.) ϕ 19.05(3/4)	ϕ 19.05(3/4)	ϕ 19.05(3/4)
Heat Pump Operation System	Gas Line	mm(in.) ϕ 38.1(1-1/2)	ϕ 38.1(1-1/2)	ϕ 38.1(1-1/2)
	Liquid Line	mm(in.) ϕ 19.05(3/4)	ϕ 19.05(3/4)	ϕ 19.05(3/4)
Connectable Indoor Units	Quantity	pcs 64	64	64
	Total Capacity	– 200%*1	200%*1	200%*1
Piping Design	Height Difference Between ODU and IDU	m(above) 50(90°)	50(90°)	50(90°)
		m(below) 40(90°)	40(90°)	40(90°)
	Height Difference Between IDUs	m 15(30°)	15(30°)	15(30°)
	Max. Piping Length	m 165	165	165
Operation Range	Cooling	DB -10°C-52°C	-10°C-52°C	-10°C-52°C
	Heating	WB -25°C-16.5°C	-25°C-16.5°C	-25°C-16.5°C

Notes:

1. Rated cooling capacity and rated heating capacity are tested in the following conditions:

Cooling conditions: indoor air inlet temperature: 27°C DB 19°C WB, outdoor air inlet temperature: 35°C DB, pipe length: 7.5m, pipe height difference: 0m.

Heating conditions: indoor air inlet temperature: 20°C DB, outdoor air inlet temperature: 7°C DB 6°C WB, pipe length: 7.5m, pipe height difference: 0m.

2. The above noise values are measured in the anechoic chamber without reflected echo, therefore the impact of the reflected echo must be included at the scene.

3. The above performance data is obtained on the basis of the performance of this outdoor unit, with a 100%-combination of 4-way cassette type indoor units.

*1*2: For detailed information, please contact with Hisense technical engineers.

Hi-FLEXi S Heat Recovery (High Efficiency)



HP		46HP	48HP	50HP	52HP
Model		AVWT-444FKFSHA	AVWT-462FKFSHA	AVWT-478FKFSHA	AVWT-494FKFSHA
Model	Modules	AVWT-154FKFSHA AVWT-154FKFSHA AVWT-136FKFSHA	AVWT-154FKFSHA AVWT-154FKFSHA AVWT-154FKFSHA	AVWT-170FKFSHA AVWT-154FKFSHA AVWT-154FKFSHA	AVWT-170FKFSHA AVWT-170FKFSHA AVWT-154FKFSHA
	Power Supply	AC 3 ϕ , 380-415V/50/60Hz			
Cooling	Capacity	kW 130.0	135.0	140.0	145.0
		kBtu/h 443.6	460.6	477.7	494.7
	Power Input	kW 31.14	33.66	35.13	36.60
	EER	kW/kW 4.17	4.01	3.99	3.96
Heating	Capacity (Max/Nom)	kW 145.0/130.0	150.0/135.0	156.0/140.0	162.0/145.0
		kBtu/h 494.7/443.6	511.8/460.6	532.3/477.7	552.7/494.7
	Power Input (Max/Nom)	kW 34.23/29.16	35.64/30.69	37.73/32.34	39.82/33.99
	COP (Max/Nom)	kW/kW 4.24/4.46	4.21/4.40	4.13/4.33	4.07/4.27
Ventilation	Air Flow Rate	m ³ /min 734	801	832	863
	Fan Quantity	6	6	6	6
	Static Pressure	Pa 110	110	110	110
Sound Pressure Level (Normal/ Silent)	dB(A)	67/58	67/59	67/59	67/59
Compressor	Type	Enhanced Vapor Injection Scroll Compressor			
	Compressor Quantity	pcs 6	6	6	6
Refrigerant	Type	R410A			
	Pre-charged Quantity	kg 28.80	29.40	30.20	31.00
	Net Weight	kg 1099	1119	1124	1129
Weight	Gross Weight	kg 1201	1224	1229	1234
	Dimensions	External(HxWxD)	mm 1730x (1210+1350+1350) x750	1730x (1350+1350+1350) x750	1730x (1350+1350+1350) x750
Packing(HxWxD)		mm 1950x (1275+1420+1420) x790	1950x (1420+1420+1420) x790	1950x (1420+1420+1420) x790	1950x (1420+1420+1420) x790
Cabinet Color		Ivory White	Ivory White	Ivory White	Ivory White
Heat Recovery Operation System	Low Pressure Gas Line	mm(in.) ϕ 38.1(1-1/2)	ϕ 38.1(1-1/2)	ϕ 38.1(1-1/2)	ϕ 38.1(1-1/2)
	High/Low Pressure Gas Line	mm(in.) ϕ 31.75(1-1/4)	ϕ 31.75(1-1/4)	ϕ 31.75(1-1/4)	ϕ 31.75(1-1/4)
	Liquid Line	mm(in.) ϕ 19.05(3/4)	ϕ 19.05(3/4)	ϕ 19.05(3/4)	ϕ 19.05(3/4)
Heat Pump Operation System	Gas Line	mm(in.) ϕ 38.1(1-1/2)	ϕ 38.1(1-1/2)	ϕ 38.1(1-1/2)	ϕ 38.1(1-1/2)
	Liquid Line	mm(in.) ϕ 19.05(3/4)	ϕ 19.05(3/4)	ϕ 19.05(3/4)	ϕ 19.05(3/4)
Connectable Indoor Units	Quantity	pcs 64	64	64	64
	Total Capacity	– 200%*1	200%*1	200%*1	200%*1
Piping Design	Height Difference Between ODU and IDU	m(above) 50(90°)	50(90°)	50(90°)	50(90°)
		m(below) 40(90°)	40(90°)	40(90°)	40(90°)
	Height Difference Between IDUs	m 15(30°)	15(30°)	15(30°)	15(30°)
	Max. Piping Length	m 165	165	165	165
Operation Range	Cooling	DB -10°C-52°C	-10°C-52°C	-10°C-52°C	-10°C-52°C
	Heating	WB -25°C-16.5°C	-25°C-16.5°C	-25°C-16.5°C	-25°C-16.5°C

Notes:

1. Rated cooling capacity and rated heating capacity are tested in the following conditions:

Cooling conditions: indoor air inlet temperature: 27°C DB 19°C WB, outdoor air inlet temperature: 35°C DB, pipe length: 7.5m, pipe height difference: 0m.

Heating conditions: indoor air inlet temperature: 20°C DB, outdoor air inlet temperature: 7°C DB 6°C WB, pipe length: 7.5m, pipe height difference: 0m.

2. The above noise values are measured in the anechoic chamber without reflected echo, therefore the impact of the reflected echo must be included at the scene.

3. The above performance data is obtained on the basis of the performance of this outdoor unit, with a 100%-combination of 4-way cassette type indoor units.

*1*2: For detailed information, please contact with Hisense technical engineers.

Hi-FLEXi S Heat Recovery (High Efficiency)



HP		54HP	56HP	58HP	60HP	
Model	Model	AVWT-510FKFSHA	AVWT-530FKFSHA	AVWT-550FKFSHA	AVWT-570FKFSHA	
	Modules	AVWT-170FKFSHA	AVWT-190FKFSHA	AVWT-190FKFSHA	AVWT-190FKFSHA	
		AVWT-170FKFSHA	AVWT-170FKFSHA	AVWT-190FKFSHA	AVWT-190FKFSHA	
Power Supply		AC 3 ϕ , 380-415V/50/60Hz				
Cooling	Capacity	150.0	156.0	162.0	168.0	
	Capacity	511.8	532.3	552.7	573.2	
	Power Input	38.07	39.74	41.41	43.08	
	EER	3.94	3.93	3.91	3.90	
Heating	Capacity (Max/Nom)	168.0/150.0	175.0/156.0	182.0/162.0	189.0/168.0	
	Capacity	573.2/511.8	597.1/532.3	621.0/552.7	644.9/573.2	
	Power Input (Max/Nom)	41.91/35.64	43.69/37.16	45.47/38.68	47.25/40.20	
Heating	COP (Max/Nom)	4.01/4.21	4.01/4.20	4.00/4.19	4.00/4.18	
	Air Flow Rate	894	946	998	1050	
	Fan Quantity	6	6	6	6	
Ventilation	Static Pressure	110	110	110	110	
	Sound Pressure Level (Normal/ Silent)	67/60	67/59	67/58	68/57	
Compressor	Type	Enhanced Vapor Injection Scroll Compressor				
	Compressor Quantity	6	6	6	6	
Refrigerant	Type	R410A				
	Pre-charged Quantity	31.80	32.70	33.60	34.50	
Weight	Net Weight	1134	1157	1180	1203	
	Gross Weight	1239	1265	1291	1317	
Dimensions	External(HxWxD)	mm	1730x (1350+1350+1350) x750	1730x (1350+1350+1600) x750	1730x (1350+1600+1600) x750	1730x (1600+1600+1600) x750
		Packing(HxWxD)	mm	1950x (1420+1420+1420) x790	1950x (1420+1420+1665) x790	1950x (1420+1665+1665) x790
	Cabinet Color		Ivory White	Ivory White	Ivory White	Ivory White
Heat Recovery Operation System	Low Pressure Gas Line	mm(in.)	ϕ 38.1(1-1/2)	ϕ 41.3(1-5/8)	ϕ 44.5(1-3/4)	ϕ 44.5(1-3/4)
	High/Low Pressure Gas Line	mm(in.)	ϕ 31.75(1-1/4)	ϕ 38.1(1-1/2)	ϕ 41.3(1-5/8)	ϕ 41.3(1-5/8)
	Liquid Line	mm(in.)	ϕ 19.05(3/4)	ϕ 22.2(7/8)	ϕ 22.2(7/8)	ϕ 22.2(7/8)
Heat Pump Operation System	Gas Line	mm(in.)	ϕ 38.1(1-1/2)	ϕ 41.3(1-5/8)	ϕ 44.5(1-3/4)	ϕ 44.5(1-3/4)
	Liquid Line	mm(in.)	ϕ 19.05(3/4)	ϕ 22.2(7/8)	ϕ 22.2(7/8)	ϕ 22.2(7/8)
Connectable Indoor Units	Quantity	pcs	64	64	64	64
	Total Capacity	-	200%*1	200%*1	200%*1	200%*1
Piping Design	Height Difference Between ODU and IDU	m(above)	50(90**)	50(90**)	50(90**)	50(90**)
	Height Difference Between IDUs	m(below)	40(90**)	40(90**)	40(90**)	40(90**)
	Height Difference Between IDUs	m	15(30**)	15(30**)	15(30**)	15(30**)
Operation Range	Max. Piping Length	m	165	165	165	165
	Cooling	DB	-10 $^{\circ}$ C-52 $^{\circ}$ C	-10 $^{\circ}$ C-52 $^{\circ}$ C	-10 $^{\circ}$ C-52 $^{\circ}$ C	-10 $^{\circ}$ C-52 $^{\circ}$ C
	Heating	WB	-25 $^{\circ}$ C-16.5 $^{\circ}$ C	-25 $^{\circ}$ C-16.5 $^{\circ}$ C	-25 $^{\circ}$ C-16.5 $^{\circ}$ C	-25 $^{\circ}$ C-16.5 $^{\circ}$ C

Notes:

1. Rated cooling capacity and rated heating capacity are tested in the following conditions:

Cooling conditions: indoor air inlet temperature: 27 $^{\circ}$ C DB 19 $^{\circ}$ C WB, outdoor air inlet temperature: 35 $^{\circ}$ C DB, pipe length: 7.5m, pipe height difference: 0m.Heating conditions: indoor air inlet temperature: 20 $^{\circ}$ C DB, outdoor air inlet temperature: 7 $^{\circ}$ C DB 6 $^{\circ}$ C WB, pipe length: 7.5m, pipe height difference: 0m.

2. The above noise values are measured in the anechoic chamber without reflected echo, therefore the impact of the reflected echo must be included at the scene.

3. The above performance data is obtained on the basis of the performance of this outdoor unit, with a 100%-combination of 4-way cassette type indoor units.

**1*: For detailed information, please contact with Hisense technical engineers.

Hi-FLEXi S Heat Recovery (High Efficiency)



HP		62HP	64HP	66HP	
Model	Model	AVWT-592FKFSHA	AVWT-614FKFSHA	AVWT-636FKFSHA	
	Modules	AVWT-212FKFSHA	AVWT-212FKFSHA	AVWT-212FKFSHA	
		AVWT-190FKFSHA	AVWT-190FKFSHA	AVWT-212FKFSHA	
Power Supply		AC 3 ϕ , 380-415V/50/60Hz			
Cooling	Capacity	173.5	179.0	184.5	
	Capacity	592.0	610.7	629.5	
	Power Input	47.13	51.18	55.23	
	EER	3.68	3.50	3.34	
Heating	Capacity (Max/Nom)	195.0/173.5	201.0/179.0	207.0/184.5	
	Capacity	665.3/592.0	685.8/610.7	706.3/629.5	
	Power Input (Max/Nom)	51.68/43.29	56.11/46.38	60.54/49.47	
Heating	COP (Max/Nom)	3.77/4.01	3.58/3.86	3.42/3.73	
	Air Flow Rate	1050	1050	1050	
	Fan Quantity	6	6	6	
Ventilation	Static Pressure	110	110	110	
	Sound Pressure Level (Normal/ Silent)	68/57	68/57	69/57	
Compressor	Type	Enhanced Vapor Injection Scroll Compressor			
	Compressor Quantity	6	6	6	
Refrigerant	Type	R410A			
	Pre-charged Quantity	34.50	34.50	34.50	
Weight	Net Weight	1204	1205	1206	
	Gross Weight	1318	1319	1320	
Dimensions	External(HxWxD)	mm	1730x (1600+1600+1600) x750	1730x (1600+1600+1600) x750	1730x (1600+1600+1600) x750
		Packing(HxWxD)	mm	1950x (1665+1665+1665) x790	1950x (1665+1665+1665) x790
	Cabinet Color		Ivory White	Ivory White	Ivory White
Heat Recovery Operation System	Low Pressure Gas Line	mm(in.)	ϕ 44.5(1-3/4)	ϕ 44.5(1-3/4)	ϕ 44.5(1-3/4)
	High/Low Pressure Gas Line	mm(in.)	ϕ 41.3(1-5/8)	ϕ 41.3(1-5/8)	ϕ 41.3(1-5/8)
	Liquid Line	mm(in.)	ϕ 22.2(7/8)	ϕ 22.2(7/8)	ϕ 22.2(7/8)
Heat Pump Operation System	Gas Line	mm(in.)	ϕ 44.5(1-3/4)	ϕ 44.5(1-3/4)	ϕ 44.5(1-3/4)
	Liquid Line	mm(in.)	ϕ 22.2(7/8)	ϕ 22.2(7/8)	ϕ 22.2(7/8)
Connectable Indoor Units	Quantity	pcs	64	64	64
	Total Capacity	-	200%*1	200%*1	200%*1
Piping Design	Height Difference Between ODU and IDU	m(above)	50(90**)	50(90**)	50(90**)
	Height Difference Between IDUs	m(below)	40(90**)	40(90**)	40(90**)
	Height Difference Between IDUs	m	15(30**)	15(30**)	15(30**)
Operation Range	Max. Piping Length	m	165	165	165
	Cooling	DB	-10 $^{\circ}$ C-52 $^{\circ}$ C	-10 $^{\circ}$ C-52 $^{\circ}$ C	-10 $^{\circ}$ C-52 $^{\circ}$ C
	Heating	WB	-25 $^{\circ}$ C-16.5 $^{\circ}$ C	-25 $^{\circ}$ C-16.5 $^{\circ}$ C	-25 $^{\circ}$ C-16.5 $^{\circ}$ C

Notes:

1. Rated cooling capacity and rated heating capacity are tested in the following conditions:

Cooling conditions: indoor air inlet temperature: 27 $^{\circ}$ C DB 19 $^{\circ}$ C WB, outdoor air inlet temperature: 35 $^{\circ}$ C DB, pipe length: 7.5m, pipe height difference: 0m.Heating conditions: indoor air inlet temperature: 20 $^{\circ}$ C DB, outdoor air inlet temperature: 7 $^{\circ}$ C DB 6 $^{\circ}$ C WB, pipe length: 7.5m, pipe height difference: 0m.

2. The above noise values are measured in the anechoic chamber without reflected echo, therefore the impact of the reflected echo must be included at the scene.

3. The above performance data is obtained on the basis of the performance of this outdoor unit, with a 100%-combination of 4-way cassette type indoor units.

**1*: For detailed information, please contact with Hisense technical engineers.

Hi-FLEXi S Heat Recovery (High Efficiency)



HP		68HP	70HP	72HP	74HP
Model	Model	AVWT-648FKFSHA	AVWT-664FKFSHA	AVWT-680FKFSHA	AVWT-700FKFSHA
	Modules	AVWT-170FKFSHA	AVWT-170FKFSHA	AVWT-170FKFSHA	AVWT-190FKFSHA
		AVWT-170FKFSHA	AVWT-170FKFSHA	AVWT-170FKFSHA	AVWT-170FKFSHA
		AVWT-154FKFSHA	AVWT-170FKFSHA	AVWT-170FKFSHA	AVWT-170FKFSHA
		AVWT-154FKFSHA	AVWT-154FKFSHA	AVWT-170FKFSHA	AVWT-170FKFSHA
Power Supply	AC 3 ϕ , 380-415V/50/60Hz				
Cooling	Capacity	190.0	195.0	200.0	206.0
	kW	648.3	665.3	682.4	702.9
	kBtu/h	47.82	49.29	50.76	52.43
	Power Input	3.97	3.96	3.94	3.93
Heating	EER	212.0/190.0	218.0/195.0	224.0/200.0	231.0/206.0
	Capacity (Max/Nom)	723.3/648.3	743.8/665.3	764.3/682.4	788.2/702.9
	kBtu/h	51.70/44.22	53.79/45.87	55.88/47.52	57.66/49.04
	Power Input (Max/Nom)	4.10/4.30	4.05/4.25	4.01/4.21	4.01/4.20
Ventilation	COP (Max/Nom)	4.10/4.30	4.05/4.25	4.01/4.21	4.01/4.20
	Air Flow Rate	1130	1161	1192	1244
	m ³ /min	8	8	8	8
Sound Pressure Level	Fan Quantity	110	110	110	110
	Static Pressure	68/61	68/61	68/61	68/60
	Pa	Enhanced Vapor Injection Scroll Compressor			
Compressor	Type	Enhanced Vapor Injection Scroll Compressor			
	Compressor Quantity	8	8	8	8
Refrigerant	Type	R410A			
	Pre-charged Quantity	40.80	41.60	42.40	43.30
	kg	1502	1507	1512	1535
Weight	Net Weight	1642	1647	1652	1678
	Gross Weight	1730x	1730x	1730x	1730x
	kg	(1350+1350+1350+1350)	(1350+1350+1350+1350)	(1350+1350+1350+1350)	(1350+1350+1350+1600)
Dimensions	External (HxWxD)	1730x	1730x	1730x	1730x
	mm	(1350+1350+1350+1350)	(1350+1350+1350+1350)	(1350+1350+1350+1350)	(1350+1350+1350+1600)
	x750	x750	x750	x750	x750
	Packing (HxWxD)	1950x	1950x	1950x	1950x
Cabinet Color	mm	(1420+1420+1420+1420)	(1420+1420+1420+1420)	(1420+1420+1420+1420)	(1420+1420+1420+1665)
	mm	(1420+1420+1420+1420)	(1420+1420+1420+1420)	(1420+1420+1420+1420)	(1420+1420+1420+1665)
	x790	x790	x790	x790	x790
	mm	Ivory White	Ivory White	Ivory White	Ivory White
Heat Recovery Operation System	Low Pressure Gas Line	mm(in.)	ϕ 50.8(2)	ϕ 50.8(2)	ϕ 50.8(2)
	High/Low Pressure Gas Line	mm(in.)	ϕ 44.5(1-3/4)	ϕ 44.5(1-3/4)	ϕ 44.5(1-3/4)
	Liquid Line	mm(in.)	ϕ 25.4(1)	ϕ 25.4(1)	ϕ 25.4(1)
Heat Pump Operation System	Gas Line	mm(in.)	ϕ 50.8(2)	ϕ 50.8(2)	ϕ 50.8(2)
	Liquid Line	mm(in.)	ϕ 25.4(1)	ϕ 25.4(1)	ϕ 25.4(1)
Connectable Indoor Units	Quantity	64	64	64	64
	Total Capacity	–	200%*1	200%*1	200%*1
Piping Design	Height Difference Between ODU and IDU	m(above)	50(90*)	50(90*)	50(90*)
	m(below)	40(90*)	40(90*)	40(90*)	40(90*)
	Height Difference Between IDUs	m	15(30*)	15(30*)	15(30*)
	Max. Piping Length	m	165	165	165
Operation Range	Cooling	DB	-10°C~52°C	-10°C~52°C	-10°C~52°C
	Heating	WB	-25°C~16.5°C	-25°C~16.5°C	-25°C~16.5°C

Notes:

1. Rated cooling capacity and rated heating capacity are tested in the following conditions:

Cooling conditions: indoor air inlet temperature: 27°C DB 19°C WB, outdoor air inlet temperature: 35°C DB, pipe length: 7.5m, pipe height difference: 0m.

Heating conditions: indoor air inlet temperature: 20°C DB, outdoor air inlet temperature: 7°C DB 6°C WB, pipe length: 7.5m, pipe height difference: 0m.

2. The above noise values are measured in the anechoic chamber without reflected echo, therefore the impact of the reflected echo must be included at the scene.

3. The above performance data is obtained on the basis of the performance of this outdoor unit, with a 100%-combination of 4-way cassette type indoor units.

*1*2: For detailed information, please contact with Hisense technical engineers.

Hi-FLEXi S Heat Recovery (High Efficiency)



HP		76HP	78HP	80HP	82HP
Model	Model	AVWT-720FKFSHA	AVWT-740FKFSHA	AVWT-760FKFSHA	AVWT-782FKFSHA
	Modules	AVWT-190FKFSHA	AVWT-190FKFSHA	AVWT-190FKFSHA	AVWT-212FKFSHA
		AVWT-190FKFSHA	AVWT-190FKFSHA	AVWT-190FKFSHA	AVWT-190FKFSHA
		AVWT-170FKFSHA	AVWT-190FKFSHA	AVWT-190FKFSHA	AVWT-190FKFSHA
		AVWT-170FKFSHA	AVWT-170FKFSHA	AVWT-190FKFSHA	AVWT-190FKFSHA
Power Supply	AC 3 ϕ , 380-415V/50/60Hz				
Cooling	Capacity	212.0	218.0	224.0	229.5
	kW	723.3	743.8	764.3	783.1
	kBtu/h	54.10	55.77	57.44	61.49
	Power Input	3.92	3.91	3.90	3.73
Heating	EER	238.0/212.0	245.0/218.0	252.0/224.0	258.0/229.5
	Capacity (Max/Nom)	812.1/723.3	835.9/743.8	859.8/764.3	880.3/783.1
	kBtu/h	59.44/50.56	61.22/52.08	63.00/53.60	67.43/56.69
	Power Input (Max/Nom)	4.00/4.19	4.00/4.19	4.00/4.18	3.83/4.05
Ventilation	COP (Max/Nom)	4.00/4.19	4.00/4.19	4.00/4.18	3.83/4.05
	Air Flow Rate	1296	1348	1400	1400
	m ³ /min	8	8	8	8
Sound Pressure Level	Fan Quantity	110	110	110	110
	Static Pressure	69/60	69/59	69/58	69/58
	Pa	Enhanced Vapor Injection Scroll Compressor			
Compressor	Type	Enhanced Vapor Injection Scroll Compressor			
	Compressor Quantity	8	8	8	8
Refrigerant	Type	R410A			
	Pre-charged Quantity	44.20	45.10	46.00	46.00
	kg	1558	1581	1604	1605
Weight	Net Weight	1704	1730	1756	1757
	Gross Weight	1730x	1730x	1730x	1730x
	kg	(1350+1350+1600+1600)	(1350+1600+1600+1600)	(1600+1600+1600+1600)	(1600+1600+1600+1600)
Dimensions	External (HxWxD)	1730x	1730x	1730x	1730x
	mm	(1350+1350+1600+1600)	(1350+1600+1600+1600)	(1600+1600+1600+1600)	(1600+1600+1600+1600)
	x750	x750	x750	x750	x750
	Packing (HxWxD)	1950x	1950x	1950x	1950x
Cabinet Color	mm	(1420+1420+1665+1665)	(1420+1665+1665+1665)	(1665+1665+1665+1665)	(1665+1665+1665+1665)
	mm	(1420+1420+1665+1665)	(1420+1665+1665+1665)	(1665+1665+1665+1665)	(1665+1665+1665+1665)
	x790	x790	x790	x790	x790
	mm	Ivory White	Ivory White	Ivory White	Ivory White
Heat Recovery Operation System	Low Pressure Gas Line	mm(in.)	ϕ 50.8(2)	ϕ 50.8(2)	ϕ 50.8(2)
	High/Low Pressure Gas Line	mm(in.)	ϕ 44.5(1-3/4)	ϕ 44.5(1-3/4)	ϕ 44.5(1-3/4)
	Liquid Line	mm(in.)	ϕ 25.4(1)	ϕ 25.4(1)	ϕ 25.4(1)
Heat Pump Operation System	Gas Line	mm(in.)	ϕ 50.8(2)	ϕ 50.8(2)	ϕ 50.8(2)
	Liquid Line	mm(in.)	ϕ 25.4(1)	ϕ 25.4(1)	ϕ 25.4(1)
Connectable Indoor Units	Quantity	64	64	64	64
	Total Capacity	–	200%*1	200%*1	200%*1
Piping Design	Height Difference Between ODU and IDU	m(above)	50(90*)	50(90*)	50(90*)
	m(below)	40(90*)	40(90*)	40(90*)	40(90*)
	Height Difference Between IDUs	m	15(30*)	15(30*)	15(30*)
	Max. Piping Length	m	165	165	165
Operation Range	Cooling	DB	-10°C~52°C	-10°C~52°C	-10°C~52°C
	Heating	WB	-25°C~16.5°C	-25°C~16.5°C	-25°C~16.5°C

Notes:

1. Rated cooling capacity and rated heating capacity are tested in the following conditions:

Cooling conditions: indoor air inlet temperature: 27°C DB 19°C WB, outdoor air inlet temperature: 35°C DB, pipe length: 7.5m, pipe height difference: 0m.

Heating conditions: indoor air inlet temperature: 20°C DB, outdoor air inlet temperature: 7°C DB 6°C WB, pipe length: 7.5m, pipe height difference: 0m.

2. The above noise values are measured in the anechoic chamber without reflected echo, therefore the impact of the reflected echo must be included at the scene.

3. The above performance data is obtained on the basis of the performance of this outdoor unit, with a 100%-combination of 4-way cassette type indoor units.

*1*2: For detailed information, please contact with Hisense technical engineers.

Hi-FLEXi S Heat Recovery (High Efficiency)



HP		84HP	86HP	88HP	
Model	Model	AVWT-804FKFSHA	AVWT-826FKFSHA	AVWT-848FKFSHA	
	Modules	AVWT-212FKFSHA	AVWT-212FKFSHA	AVWT-212FKFSHA	
		AVWT-190FKFSHA	AVWT-212FKFSHA	AVWT-212FKFSHA	
		AVWT-190FKFSHA	AVWT-212FKFSHA	AVWT-212FKFSHA	
Power Supply		AC 3Φ, 380-415V/50/60Hz			
Cooling	Capacity	235.0	240.5	246.0	
	Capacity	kBtu/h	801.8	820.6	839.4
	Power Input	kW	65.54	69.59	73.64
	EER	kW/kW	3.59	3.46	3.34
Heating	Capacity (Max/Nom)	kW	264.0/235.0	270.0/240.5	276.0/246.0
	Capacity (Max/Nom)	kBtu/h	900.8/801.8	921.2/820.6	941.7/839.4
	Power Input (Max/Nom)	kW	71.86/59.78	76.29/62.87	80.72/65.96
	COP (Max/Nom)	kW/kW	3.67/3.93	3.54/3.83	3.42/3.73
Ventilation	Air Flow Rate	m ³ /min	1400	1400	1400
	Fan Quantity		8	8	8
	Static Pressure	Pa	110	110	110
Sound Pressure Level (Normal/ Silent)	dB(A)	70/58	70/58	70/58	
Compressor	Type	Enhanced Vapor Injection Scroll Compressor			
	Compressor Quantity	pcs	8	8	8
Refrigerant	Type	R410A			
	Pre-charged Quantity	kg	46.00	46.00	46.00
Weight	Net Weight	kg	1606	1607	1608
	Gross Weight	kg	1758	1759	1760
Dimensions	External(HxWxD)	mm	1730x (1600+1600+1600+1600) x750	1730x (1600+1600+1600+1600) x750	1730x (1600+1600+1600+1600) x750
	Packing(HxWxD)	mm	1950x (1665+1665+1665+1665) x790	1950x (1665+1665+1665+1665) x790	1950x (1665+1665+1665+1665) x790
		Cabinet Color		Ivory White	Ivory White
	Heat Recovery Operation System	Low Pressure Gas Line	mm(in.)	Φ50.8(2)	Φ50.8(2)
High/Low Pressure Gas Line		mm(in.)	Φ44.5(1-3/4)	Φ44.5(1-3/4)	Φ44.5(1-3/4)
Liquid Line		mm(in.)	Φ25.4(1)	Φ25.4(1)	Φ25.4(1)
Heat Pump Operation System	Gas Line	mm(in.)	Φ50.8(2)	Φ50.8(2)	Φ50.8(2)
	Liquid Line	mm(in.)	Φ25.4(1)	Φ25.4(1)	Φ25.4(1)
Connectable Indoor Units	Quantity	pcs	64	64	64
	Total Capacity	-	200%*1	200%*1	200%*1
Piping Design	Height Difference Between ODU and IDU	m(above)	50(90°)	50(90°)	50(90°)
	Height Difference Between IDUs	m(below)	40(90°)	40(90°)	40(90°)
	Max. Piping Length	m	15(30°)	15(30°)	15(30°)
Operation Range	Cooling	DB	-10°C-52°C	-10°C-52°C	-10°C-52°C
	Heating	WB	-25°C-16.5°C	-25°C-16.5°C	-25°C-16.5°C

Notes:
 1. Rated cooling capacity and rated heating capacity are tested in the following conditions:
 Cooling conditions: indoor air inlet temperature: 27°C DB 19°C WB, outdoor air inlet temperature: 35°C DB, pipe length: 7.5m, pipe height difference: 0m.
 Heating conditions: indoor air inlet temperature: 20°C DB, outdoor air inlet temperature: 7°C DB 6°C WB, pipe length: 7.5m, pipe height difference: 0m.
 2. The above noise values are measured in the anechoic chamber without reflected echo, therefore the impact of the reflected echo must be included at the scene.
 3. The above performance data is obtained on the basis of the performance of this outdoor unit, with a 100%-combination of 4-way cassette type indoor units.
 **2: For detailed information, please contact with Hisense technical engineers.

Switch Box

Introduction

It's used for heat recovery systems to achieve simultaneous cooling and heating in one system, and very important to realize installation flexibility and reduce costs.

Advantage

- Compact body and convenient installation.
- Enrich the products (1,4,8,12,16).
- Maximize capacity to 16kW or more.
- Require no drain pipes or drainage connections.
- Combine between single branch and multi-branch flexibility.

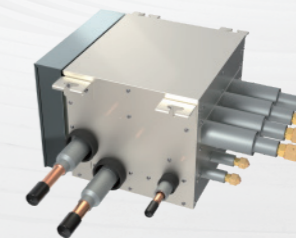

Model	Single Branch		Multiple Branch							
	HCHS-N06XC	HCHS-N10XC	HCHM-N04XC	HCHM-N08XC	HCHM-N12XC	HCHM-N16XC				
Appearance										
Electrical	Power Supply		AC 1Φ, 220-240V/50Hz; AC 1Φ, 208-230V/60Hz							
	Power Input		W	5.8	5.8	15.1	29.8	45.0	60.0	
Maximum Total Capacity of All Connected Indoor Units	kW		16.0	28.0	44.8	85.0	85.0	85.0		
Maximum Total Capacity of Connected Indoor Units Per Port	kW		16.0	28.0	16.0	16.0	16.0	16.0		
Number of Ports (for Indoor Unit)	pcs		1	1	4	8	12	16		
Maximum Number of Connected Indoor Units Per Port	pcs		8	8	8	8	6	6		
Outer Dimensions(H x W x D)	mm		191x300x214	191x300x214	260x303x352	260x543x352	260x783x352	260x1023x352		
Net Weight	kg		6.3	6.4	14.1	25.2	35.5	46.7		
Noise Level	Operation Noise		dB(A)		33	33	31	31	34	34
	Max Noise		dB(A)		46	46	43	46	48	49
Refrigerant			R410A							
Refrigerant Piping (Outdoor Unit Side)	Gas Line (High/Low Pressure)		mm		15.88	15.88	22.2	22.2	25.4	28.6
	Gas Line (Low Pressure)		mm		19.05	19.05	25.4	28.6	28.6	31.75
	Liquid Line		mm		—	—	12.7	12.7	15.88	19.05
Refrigerant Piping (Indoor Unit Side)	Gas Line		mm		15.88	19.05	15.88	15.88	15.88	15.88
	Liquid Line		mm		—	—	9.52	9.52	9.52	9.52

Hydro Box

Specification for Hydro Box

Model		AHM-080FJFAA	AHM-160FJFAA
Power Supply		AC 1Φ, 220~240V/50Hz AC 1Φ, 220V/60Hz	
Cooling Capacity (A 35/24°C/W 12~7°C)		7.5	12.5
Heating Capacity (A 7/6°C/W 30~35°C)	kW	8	16
Power Input	kW	0.08(3.08)	0.14(3.14)
Dimensions	H × W × D	890 × 520 × 320	890 × 520 × 320
Packing Dimensions	H × W × D	1120 × 595 × 462	1120 × 595 × 462
Weight	Net	kg	55
	Gross	kg	72
Heat Exchanger		Plate Heat Exchanger	
Heat Exchanger Insulation Material		Elastomeric Foam	
Water Production	Heating	°C	20 to 55
	DHW(with electric heater)	°C	35 to 75
Sound Pressure	Cooling	°C	5 to 20
		dB(A)	33
Sound Power		dB(A)	46
			46
Piping Connections	Gas	mm	φ15.88
	Liquid	mm	φ9.53
Water Pump	Type		DC Motor
	Speed		Inverter Control
	Pumping Head	m	12.5
Booster Heating	Pumping Head for Water Circuit		5
	Power Input	w	100
		kW	3
Water Filter	Diameter Perforations	mm	0.85
	Material		Hpb59-1
Water Circuit	Piping Connections Diameter	mm	G1-1/4"
	Shut off Valve		Yes
	Drain Valve		Yes
	Safety Valve	Bar	3
	Air Purge Valve		Yes
Nominal Water		m ³ /h	1.38
Expansion Vessel	Volume	L	8
	Max. Water Pressure	Bar	3

Operation Range

Indoor Unit Cooling

	Maximum	Minimum
Indoor	32°C DB / 23°C WB	21°C DB / 15°C WB
Outdoor	52°C DB*	-10°C DB

Hydro Box Cooling

	Maximum	Minimum
Inlet Water	25°C	10°C
Outdoor	48°C DB	10°C DB

Hydro Box Heating (DHW)

	Maximum	Minimum
Inlet Water	54°C	10°C
Outdoor	43°C WB	-25°C WB**

Indoor Unit Heating

	Maximum	Minimum
Indoor	27°C DB	15°C DB
Outdoor	16.5°C WB	-25°C WB**

Hydro Box Heating (Floor Heating)

	Maximum	Minimum
Inlet Water	54°C	10°C
Outdoor	16.5°C WB	-25°C WB**

DB: Dry Bulb
WB: Wet Bulb
(*): 48°C DB ~ 52°C DB, Operation Control Range
(**): -20°C WB ~ -25°C WB, Operation Control Range



Hi-FLEXi mavo+ Series

Extra Long Pipe Design

With extra long pipe, the height difference between the indoor unit and outdoor unit is up to 90 meters*, which makes installation more flexible.

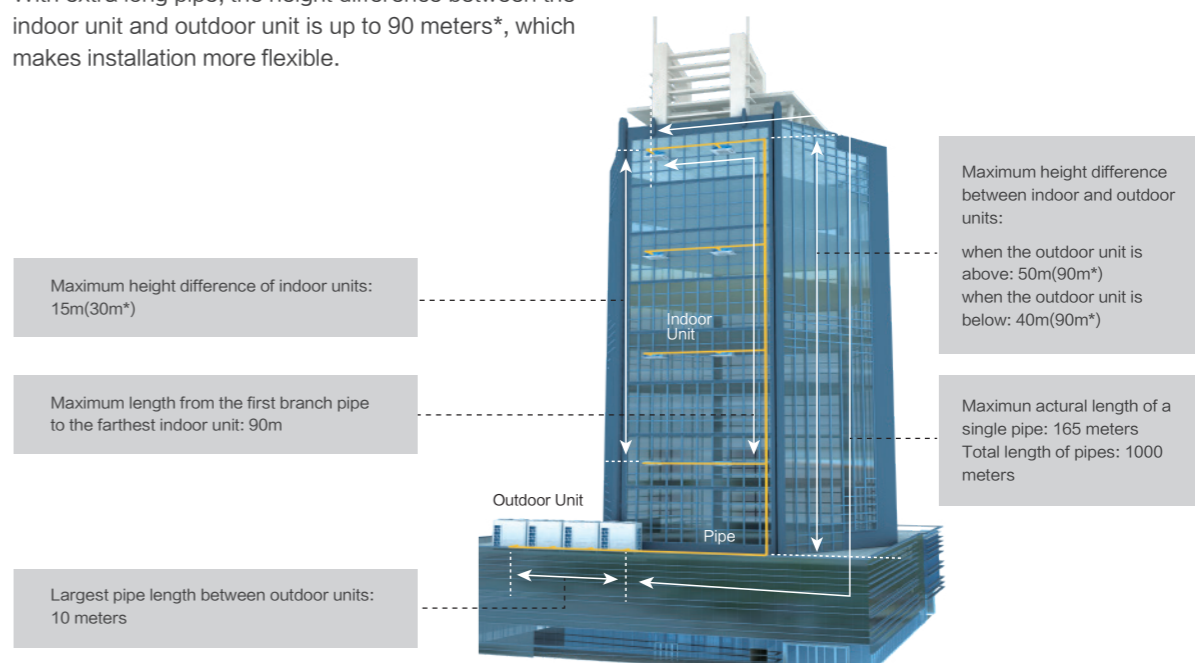

*Note: For detailed information, please contact Hisense's technical staff.

High-efficiency Compressor

Hi-FLEXi S mavo+ series adopts a new generation of scroll compressor, and it has an excellent mechanism called as FCM (Frame Compliant Mechanism) which will optimally increase the performance of the whole compressor, especially for operation under low load.

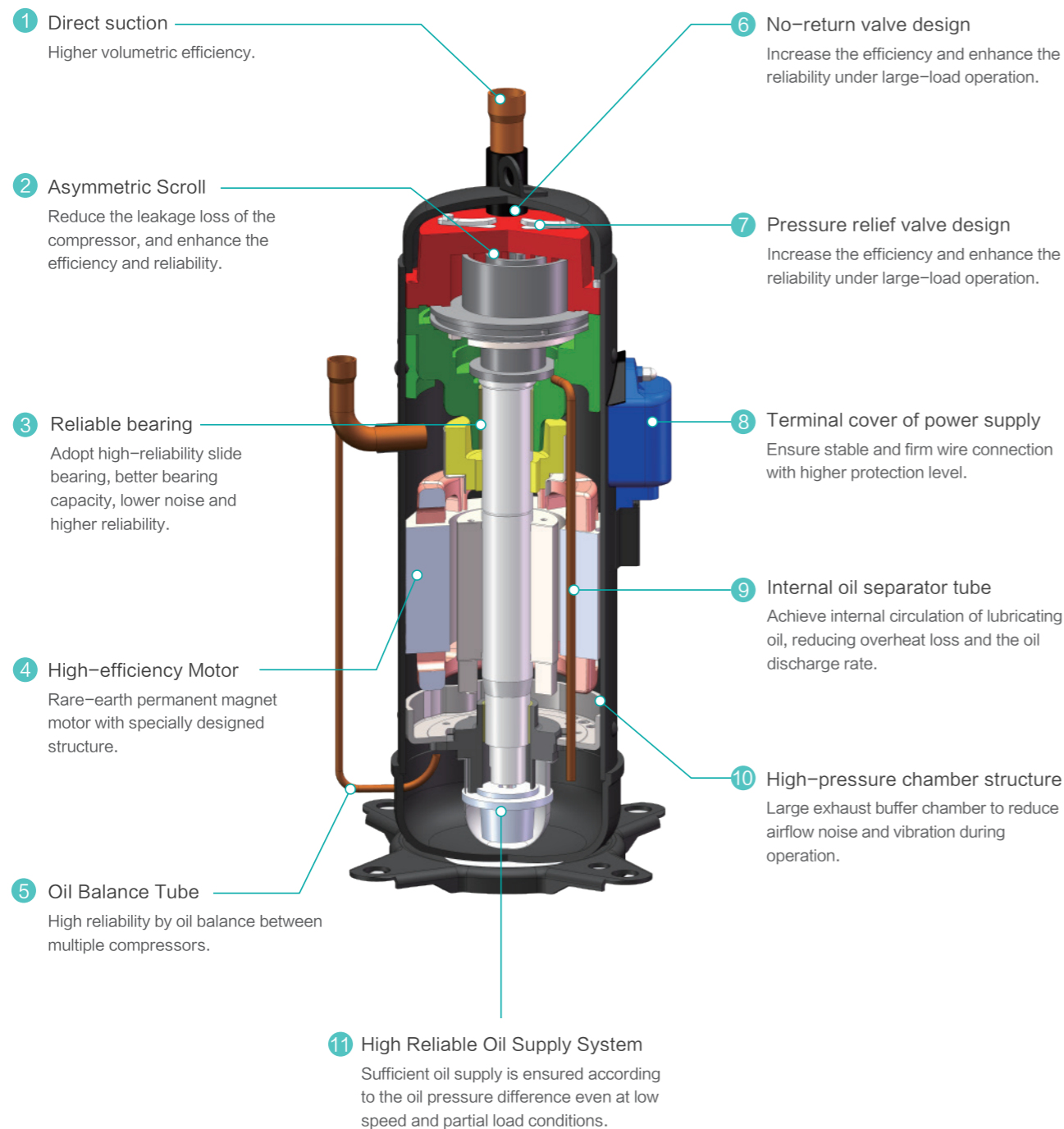

Hi-FLEXi S mavo+ Series



		HP	8HP	10HP	12HP	14HP	16HP
Model			AVWT-76HKFSEB	AVWT-96HKFSEB	AVWT-114HKFSEB	AVWT-136HKFSEB	AVWT-154HKFSEB
Model			—	—	—	—	—
Power Supply			AC 3Φ, 380-415V/50/60Hz				
Cooling	Capacity	kW	22.4	28.0	33.5	40.0	45.0
		kBtu/h	76.4	95.5	114.3	136.5	153.5
	Power Input	kW	6.93	9.33	11.55	14.04	16.67
	EER	kW/kW	3.23	3.00	2.90	2.85	2.70
	SEER	kW/kW	6.46	7.19	7.17	6.54	6.46
Heating	Capacity (Max/Nom)	kW	25.0/22.4	31.5/28.0	37.5/33.5	45.0/40.0	50.0/45.0
		kBtu/h	85.3/76.4	107.5/95.5	128.0/114.3	153.5/136.5	170.6/153.5
	Power Input (Max/Nom)	kW	7.05/5.96	8.81/7.55	10.71/9.49	13.15/11.46	14.90/13.24
	COP (Max/Nom)	kW/kW	3.55/3.76	3.58/3.71	3.50/3.53	3.42/3.49	3.35/3.40
	SCOP	kW/kW	4.09	4.18	4.20	4.07	4.09
Ventilation	Air Flow Rate	m ³ /min	183	183	183	200	200
	Fan Quantity	pcs	1	1	1	2	2
	Static Pressure	Pa	110	110	110	110	110
Sound Pressure Level	Normal Mode	dB(A)	56	57	59	59	60
	Night Shift Mode	dB(A)	41	42	44	44	45
Compressor	Type	—	Scroll Comp				
	Quantity	pcs	1	1	1	1	1
Refrigerant	Type	—	R410A				
	Pre-charged Amount	kg	5.3	5.3	6.2	8.0	8.0
Weight	Net Weight	kg	217	219	223	272	273
	Gross Weight	kg	246	248	252	306	307
Dimensions	External(HxWxD)	mm	1730x950x750	1730x950x750	1730x950x750	1730x1210x750	1730x1210x750
	Packing(HxWxD)	mm	1950x1015x790	1950x1015x790	1950x1275x790	1950x1275x790	1950x1275x790
Cabinet Color			Ivory White	Ivory White	Ivory White	Ivory White	Ivory White
Ref. Piping	Gas	mm	φ19.05	φ22.20	φ25.40	φ25.40	φ28.60
		inch	3/4	7/8	1	1	1-1/8
	Liquid	mm	φ9.53	φ9.53	φ12.70	φ12.70	φ12.70
	inch	3/8	3/8	1/2	1/2	1/2	
Connectable Indoor Units	Quantity	pcs	15	19	22	27	30
	Total Capacity	—	50%~150%	50%~150%	50%~150%	50%~150%	50%~150%
Piping Design	Height Difference Between ODU and IDU	m(above)	50(90 ^{**})	50(90 ^{**})	50(90 ^{**})	50(90 ^{**})	50(90 ^{**})
		m(below)	40(90 ^{**})	40(90 ^{**})	40(90 ^{**})	40(90 ^{**})	40(90 ^{**})
	Height Difference Between IDUs	m	30	30	30	30	30
	Max. Piping Length	m	1000	1000	1000	1000	1000
Operation Range ^{**}	Cooling	DB	-5°C~52°C	-5°C~52°C	-5°C~52°C	-5°C~52°C	-5°C~52°C
	Heating	WB	-25°C~16.5°C	-25°C~16.5°C	-25°C~16.5°C	-25°C~16.5°C	-25°C~16.5°C

Notes:
 1. Rated capacity is tested in the following conditions:
 Pipe length: 7.5m, Pipe height difference: 0m; Cooling operation: indoor air inlet temperature 27°CDB 19°CWB, outdoor ambient temperature 35°CDB;
 Heating operation: indoor air inlet temperature 20°CDB, outdoor ambient temperature 7°CDB 6°CWB.
 2. The above noise values are measured in the anechoic chamber without reflected echo. Measurement point: 1 meter from the service cover surface and 1.5 meters from floor level.
 3. The above performance data is obtained on the basis of the performance of this outdoor unit, with a 100%-combination of 4-way cassette type indoor units.
 *: For height difference between ODU & IDU more than 50(40)m, please contact with our professional engineer.
 **: When the operation temperature is under 48°C DB ~ 52°C DB or -25°C WB ~ -20°C WB, the system may be in intermittent operation. Please contact with ur professional engineer.

Hi-FLEXi S mavo+ Series



HP		18HP	20HP	22HP	24HP
Model		AVWT-170HKFSEB	AVWT-190HKFSEB	AVWT-212HKFSEB	AVWT-232HKFSEB
Modules		—	—	—	—
Power Supply		AC 3 ϕ , 380-415V/50/60Hz			
Cooling	Capacity	kW 50.0	56.0	61.5	68.0
		kBtu/h 170.6	191.1	209.8	232.0
	Power Input	kW 20.83	23.83	27.33	30.36
	EER	kW/kW 2.40	2.35	2.25	2.24
	SEER	kW/kW 6.44	6.37	6.12	6.09
Heating	Capacity (Max/Nom)	kW 56.0/50.0	63.0/56.0	69.0/61.5	75.0/68.0
		kBtu/h 191.1/170.6	215.0/191.1	235.4/209.8	255.9/232.0
	Power Input (Max/Nom)	kW 17.30/15.02	19.51/16.47	22.06/19.16	24.09/21.38
	COP (Max/Nom)	kW/kW 3.24/3.33	3.23/3.40	3.12/3.21	3.11/3.18
Ventilation	SCOP	kW/kW 4.16	4.07	4.05	3.93
	Air Flow Rate	m ³ /min 200	267	296	350
	Fan Quantity	pcs 2	2	2	2
Sound Pressure Level	Static Pressure	Pa 110	110	110	110
	Normal Mode	dB(A) 61	62	63	64
Compressor	Night Shift Mode	dB(A) 46	47	48	49
	Type	—	Scroll Compressor		
Refrigerant	Quantity	pcs 1	1	2	2
	Type	—	R410A		
Weight	Pre-charged Amount	kg 9.6	10.3	12.2	12.0
	Net Weight	kg 296	316	363	391
Dimensions	Gross Weight	kg 330	347	400	433
	External(HxWxD)	mm 1730x1210x750	1730x1350x750	1730x1350x750	1730x1600x750
Cabinet Color	Packing(HxWxD)	mm 1950x1420x790	1950x1420x790	1950x1420x790	1950x1665x790
	Gas	mm ϕ 28.60	ϕ 28.60	ϕ 28.60	ϕ 28.60
Ref. Piping	Liquid	mm ϕ 15.88	ϕ 15.88	ϕ 15.88	ϕ 15.88
	Quantity	inch 5/8	5/8	5/8	5/8
Connectable Indoor Units	Total Capacity	pcs 34	38	41	46
	Height Difference Between ODU and IDU	—	50%~150%	50%~150%	50%~150%
Piping Design	Height Difference Between IDUs	m(above) 50(90**)	50(90**)	50(90**)	50(90**)
	Max. Piping Length	m(below) 40(90**)	40(90**)	40(90**)	40(90**)
	Max. Piping Length	m 30	30	30	30
Operation Range*2	Max. Piping Length	m 1000	1000	1000	1000
	Cooling	DB -5 $^{\circ}$ C~-52 $^{\circ}$ C	-5 $^{\circ}$ C~-52 $^{\circ}$ C	-5 $^{\circ}$ C~-52 $^{\circ}$ C	-5 $^{\circ}$ C~-52 $^{\circ}$ C
	Heating	WB -25 $^{\circ}$ C~-16.5 $^{\circ}$ C	-25 $^{\circ}$ C~-16.5 $^{\circ}$ C	-25 $^{\circ}$ C~-16.5 $^{\circ}$ C	-25 $^{\circ}$ C~-16.5 $^{\circ}$ C

Notes:

- Rated capacity is tested in the following conditions:
Pipe length: 7.5m, Pipe height difference: 0m; Cooling operation: indoor air inlet temperature 27 $^{\circ}$ CDB 19 $^{\circ}$ CWB, outdoor ambient temperature 35 $^{\circ}$ CDB;
Heating operation: indoor air inlet temperature 20 $^{\circ}$ CDB, outdoor ambient temperature 7 $^{\circ}$ CDB 6 $^{\circ}$ CWB.
- The above noise values are measured in the anechoic chamber without reflected echo. Measurement point: 1 meter from the service cover surface and 1.5 meters from floor level.
- The above performance data is obtained on the basis of the performance of this outdoor unit, with a 100%-combination of 4-way cassette type indoor units.
*: For height difference between ODU & IDU more than 50(40)m, please contact with our professional engineer.
?: When the operation temperature is under 48 $^{\circ}$ C DB ~ 52 $^{\circ}$ C DB or -25 $^{\circ}$ C WB ~ -20 $^{\circ}$ C WB, the system may be in intermittent operation. Please contact with ur professional engineer.

Hi-FLEXi S mavo+ Series



HP		26HP	28HP	30HP	32HP
Model		AVWT-250HKFSEB	AVWT-272HKFSEB	AVWT-290HKFSEB	AVWT-308HKFSEB
Modules		AVWT-114HKFSEB AVWT-136HKFSEB	AVWT-136HKFSEB AVWT-136HKFSEB	AVWT-136HKFSEB AVWT-154HKFSEB	AVWT-154HKFSEB AVWT-154HKFSEB
Power Supply		AC 3 ϕ , 380-415V/50/60Hz			
Cooling	Capacity	kW 73.5	80.0	85.0	90.0
		kBtu/h 250.8	273.0	290.0	307.1
	Power Input	kW 25.59	28.07	30.70	33.33
	EER	kW/kW 2.87	2.85	2.77	2.70
	SEER	kW/kW 6.82	6.54	6.50	6.46
Heating	Capacity (Max/Nom)	kW 82.5/73.5	90.0/80.0	95.0/85.0	100.0/90.0
		kBtu/h 281.5/250.8	307.1/273.0	324.1/290.0	341.2/307.1
	Power Input (Max/Nom)	kW 23.85/20.95	26.29/22.92	28.05/24.70	29.81/26.48
	COP (Max/Nom)	kW/kW 3.46/3.51	3.42/3.49	3.39/3.44	3.35/3.40
Ventilation	SCOP	kW/kW 4.13	4.07	4.08	4.09
	Air Flow Rate	m ³ /min 383	400	400	400
	Fan Quantity	pcs 3	4	4	4
Sound Pressure Level	Static Pressure	Pa 110	110	110	110
	Normal Mode	dB(A) 62	62	63	63
Compressor	Night Shift Mode	dB(A) 47	47	48	48
	Type	—	Scroll Compressor		
Refrigerant	Quantity	pcs 2	2	2	2
	Type	—	R410A		
Weight	Pre-charged Amount	kg 14.2	16.0	16.0	16.0
	Net Weight	kg 223+272	272+272	272+273	273+273
Dimensions	Gross Weight	kg 252+306	306+306	306+307	307+307
	External(HxWxD)	mm 1730x (950+1210)	1730x (1210+1210)	1730x (1210+1210)	1730x (1210+1210)
Cabinet Color	Packing(HxWxD)	mm 1950x (1275+1275)	1950x (1275+1275)	1950x (1275+1275)	1950x (1275+1275)
	Gas	mm ϕ 31.75	ϕ 31.75	ϕ 31.75	ϕ 31.75
Ref. Piping	Liquid	mm ϕ 19.05	ϕ 19.05	ϕ 19.05	ϕ 19.05
	Quantity	inch 3/4	3/4	3/4	3/4
Connectable Indoor Units	Total Capacity	pcs 49	54	57	61
	Height Difference Between ODU and IDU	—	50%~150%	50%~150%	50%~150%
Piping Design	Height Difference Between IDUs	m(above) 50(90**)	50(90**)	50(90**)	50(90**)
	Max. Piping Length	m(below) 40(90**)	40(90**)	40(90**)	40(90**)
	Max. Piping Length	m 30	30	30	30
Operation Range*2	Max. Piping Length	m 1000	1000	1000	1000
	Cooling	DB -5 $^{\circ}$ C~-52 $^{\circ}$ C	-5 $^{\circ}$ C~-52 $^{\circ}$ C	-5 $^{\circ}$ C~-52 $^{\circ}$ C	-5 $^{\circ}$ C~-52 $^{\circ}$ C
	Heating	WB -25 $^{\circ}$ C~-16.5 $^{\circ}$ C	-25 $^{\circ}$ C~-16.5 $^{\circ}$ C	-25 $^{\circ}$ C~-16.5 $^{\circ}$ C	-25 $^{\circ}$ C~-16.5 $^{\circ}$ C

Notes:

- Rated capacity is tested in the following conditions:
Pipe length: 7.5m, Pipe height difference: 0m; Cooling operation: indoor air inlet temperature 27 $^{\circ}$ CDB 19 $^{\circ}$ CWB, outdoor ambient temperature 35 $^{\circ}$ CDB;
Heating operation: indoor air inlet temperature 20 $^{\circ}$ CDB, outdoor ambient temperature 7 $^{\circ}$ CDB 6 $^{\circ}$ CWB.
- The above noise values are measured in the anechoic chamber without reflected echo. Measurement point: 1 meter from the service cover surface and 1.5 meters from floor level.
- The above performance data is obtained on the basis of the performance of this outdoor unit, with a 100%-combination of 4-way cassette type indoor units.
*: For height difference between ODU & IDU more than 50(40)m, please contact with our professional engineer.
?: When the operation temperature is under 48 $^{\circ}$ C DB ~ 52 $^{\circ}$ C DB or -25 $^{\circ}$ C WB ~ -20 $^{\circ}$ C WB, the system may be in intermittent operation. Please contact with ur professional engineer.

Hi-FLEXi S mavo+ Series



HP		34HP	36HP	38HP	40HP
Model	Model	AVWT-324HKFSEB	AVWT-340HKFSEB	AVWT-360HKFSEB	AVWT-380HKFSEB
	Modules	AVWT-154HKFSEB AVWT-170HKFSEB	AVWT-170HKFSEB AVWT-170HKFSEB	AVWT-170HKFSEB AVWT-190HKFSEB	AVWT-190HKFSEB AVWT-190HKFSEB
Power Supply		AC 3 Φ , 380-415V/50/60Hz			
Cooling	Capacity	95.0	100.0	106.0	112.0
	kBtu/h	324.1	341.2	361.7	382.1
	Power Input	37.50	41.67	44.66	47.66
	EER	2.53	2.40	2.37	2.35
	SEER	6.45	6.44	6.40	6.37
Heating	Capacity (Max/Nom)	106.0/95.0	112.0/100.0	119.0/106.0	126.0/112.0
	kBtu/h	361.7/324.1	382.1/341.2	406.0/361.7	429.9/382.1
	Power Input (Max/Nom)	32.20/28.26	34.59/30.04	36.81/31.49	39.02/32.94
	COP (Max/Nom)	3.29/3.36	3.24/3.33	3.23/3.37	3.23/3.40
Ventilation	SCOP	4.13	4.16	4.11	4.07
	Air Flow Rate	400	400	467	534
	Fan Quantity	4	4	4	4
Sound Pressure Level	Static Pressure	110	110	110	110
	Normal Mode	64	64	65	65
Compressor	Night Shift Mode	49	49	50	50
	Type	Scroll Compressor			
Refrigerant	Quantity	2	2	2	2
	Type	R410A			
Weight	Pre-charged Amount	17.6	19.2	19.9	20.6
	Net Weight	273+296	296+296	296+316	316+316
	Gross Weight	307+330	330+330	330+347	347+347
Dimensions	External(HxWxD)	1730x (1210+1210)	1730x (1210+1210)	1730x (1210+1350)	1730x (1350+1350)
	Packing(HxWxD)	1950x (1275+1420)	1950x (1420+1420)	1950x (1420+1420)	1950x (1420+1420)
	Cabinet Color	Ivory White	Ivory White	Ivory White	Ivory White
	Ref. Piping	Gas	ϕ 38.1	ϕ 38.1	ϕ 38.1
Connectable Indoor Units	Liquid	1-1/2	1-1/2	1-1/2	1-1/2
	Quantity	ϕ 19.05	ϕ 19.05	ϕ 19.05	ϕ 19.05
Piping Design	Total Capacity	3/4	3/4	3/4	3/4
	Height Difference Between ODU and IDU	64	64	64	64
	Height Difference Between IDUs	50%-150%	50%-150%	50%-150%	50%-150%
Operation Range*2	Max. Piping Length	m	30	30	30
	Cooling	m	1000	1000	1000
Operation Range*2	Heating	DB	-5 $^{\circ}$ C~52 $^{\circ}$ C	-5 $^{\circ}$ C~52 $^{\circ}$ C	-5 $^{\circ}$ C~52 $^{\circ}$ C
	Heating	WB	-25 $^{\circ}$ C~16.5 $^{\circ}$ C	-25 $^{\circ}$ C~16.5 $^{\circ}$ C	-25 $^{\circ}$ C~16.5 $^{\circ}$ C

Notes:

1. Rated capacity is tested in the following conditions:

Pipe length: 7.5m, Pipe height difference: 0m; Cooling operation: indoor air inlet temperature 27 $^{\circ}$ CDB 19 $^{\circ}$ CWB, outdoor ambient temperature 35 $^{\circ}$ CDB; Heating operation: indoor air inlet temperature 20 $^{\circ}$ CDB, outdoor ambient temperature 7 $^{\circ}$ CDB 6 $^{\circ}$ CWB.

2. The above noise values are measured in the anechoic chamber without reflected echo. Measurement point: 1 meter from the service cover surface and 1.5 meters from floor level.

3. The above performance data is obtained on the basis of the performance of this outdoor unit, with a 100%-combination of 4-way cassette type indoor units.

*: For height difference between ODU & IDU more than 50(40)m, please contact with our professional engineer.

*: When the operation temperature is under 48 $^{\circ}$ C DB ~ 52 $^{\circ}$ C DB or -25 $^{\circ}$ C WB ~ -20 $^{\circ}$ C WB, the system may be in intermittent operation. Please contact with ur professional engineer.

Hi-FLEXi S mavo+ Series



HP		42HP	44HP	46HP	48HP
Model	Model	AVWT-402HKFSEB	AVWT-424HKFSEB	AVWT-444HKFSEB	AVWT-464HKFSEB
	Modules	AVWT-190HKFSEB AVWT-212HKFSEB	AVWT-212HKFSEB AVWT-212HKFSEB	AVWT-212HKFSEB AVWT-232HKFSEB	AVWT-232HKFSEB AVWT-232HKFSEB
Power Supply		AC 3 Φ , 380-415V/50/60Hz			
Cooling	Capacity	117.5	123.0	129.5	136.0
	kBtu/h	400.9	419.7	441.9	464.0
	Power Input	51.16	54.67	57.69	60.72
	EER	2.30	2.25	2.24	2.24
	SEER	6.24	6.12	6.10	6.09
Heating	Capacity (Max/Nom)	132.0/117.5	138.0/123.0	144.0/129.5	150.0/136.0
	kBtu/h	450.4/400.9	470.9/419.7	491.3/441.9	511.8/464.0
	Power Input (Max/Nom)	41.57/35.63	44.11/38.32	46.15/40.54	48.18/42.76
	COP (Max/Nom)	3.18/3.30	3.13/3.21	3.12/3.19	3.11/3.18
Ventilation	SCOP	4.06	4.05	3.98	3.93
	Air Flow Rate	563	592	646	700
	Fan Quantity	4	4	4	4
Sound Pressure Level	Static Pressure	110	110	110	110
	Normal Mode	66	66	67	67
Compressor	Night Shift Mode	51	51	52	52
	Type	Scroll Compressor			
Refrigerant	Quantity	3	4	4	4
	Type	R410A			
Weight	Pre-charged Amount	22.5	24.4	24.2	24.0
	Net Weight	316+363	363+363	363+391	391+391
	Gross Weight	347+400	400+400	400+433	433+433
Dimensions	External(HxWxD)	1730x (1350+1350)	1730x (1350+1350)	1730x (1350+1600)	1730x (1600+1600)
	Packing(HxWxD)	1950x (1420+1420)	1950x (1420+1420)	1950x (1420+1665)	1950x (1665+1665)
	Cabinet Color	Ivory White	Ivory White	Ivory White	Ivory White
	Ref. Piping	Gas	ϕ 38.1	ϕ 38.1	ϕ 41.3
Connectable Indoor Units	Liquid	1-1/2	1-1/2	1-5/8	1-5/8
	Quantity	ϕ 19.05	ϕ 19.05	ϕ 22.2	ϕ 22.2
Piping Design	Total Capacity	3/4	3/4	7/8	7/8
	Height Difference Between ODU and IDU	64	64	64	64
	Height Difference Between IDUs	50%-150%	50%-150%	50%-150%	50%-150%
Operation Range*2	Max. Piping Length	m	30	30	30
	Cooling	m	1000	1000	1000
Operation Range*2	Heating	DB	-5 $^{\circ}$ C~52 $^{\circ}$ C	-5 $^{\circ}$ C~52 $^{\circ}$ C	-5 $^{\circ}$ C~52 $^{\circ}$ C
	Heating	WB	-25 $^{\circ}$ C~16.5 $^{\circ}$ C	-25 $^{\circ}$ C~16.5 $^{\circ}$ C	-25 $^{\circ}$ C~16.5 $^{\circ}$ C

Notes:

1. Rated capacity is tested in the following conditions:

Pipe length: 7.5m, Pipe height difference: 0m; Cooling operation: indoor air inlet temperature 27 $^{\circ}$ CDB 19 $^{\circ}$ CWB, outdoor ambient temperature 35 $^{\circ}$ CDB; Heating operation: indoor air inlet temperature 20 $^{\circ}$ CDB, outdoor ambient temperature 7 $^{\circ}$ CDB 6 $^{\circ}$ CWB.

2. The above noise values are measured in the anechoic chamber without reflected echo. Measurement point: 1 meter from the service cover surface and 1.5 meters from floor level.

3. The above performance data is obtained on the basis of the performance of this outdoor unit, with a 100%-combination of 4-way cassette type indoor units.

*: For height difference between ODU & IDU more than 50(40)m, please contact with our professional engineer.

*: When the operation temperature is under 48 $^{\circ}$ C DB ~ 52 $^{\circ}$ C DB or -25 $^{\circ}$ C WB ~ -20 $^{\circ}$ C WB, the system may be in intermittent operation. Please contact with ur professional engineer.

Hi-FLEXi S mavo+ Series



HP		50HP	52HP	54HP	56HP	
Model	Model	AVWT-478HKFSEB	AVWT-494HKFSEB	AVWT-510HKFSEB	AVWT-530HKFSEB	
	Modules	AVWT-154HKFSEB	AVWT-154HKFSEB	AVWT-170HKFSEB	AVWT-170HKFSEB	
		AVWT-154HKFSEB	AVWT-170HKFSEB	AVWT-170HKFSEB	AVWT-190HKFSEB	
Power Supply		AC 3Φ, 380-415V/50/60Hz				
Cooling	Capacity	kW	140.0	145.0	150.0	156.0
		kBtu/h	477.7	494.7	511.8	532.3
	Power Input	kW	54.17	58.33	62.50	65.50
	EER	kW/kW	2.58	2.49	2.40	2.38
	SEER	kW/kW	6.45	6.44	6.44	6.41
Heating	Capacity (Max/Nom)	kW	156.0/140.0	162.0/145.0	168.0/150.0	175.0/156.0
		kBtu/h	532.3/477.7	552.7/494.7	573.2/511.8	597.1/532.3
	Power Input (Max/Nom)	kW	47.10/41.50	49.50/43.28	51.89/45.06	54.10/46.51
	COP (Max/Nom)	kW/kW	3.31/3.37	3.27/3.35	3.24/3.33	3.23/3.35
Ventilation	SCOP	kW/kW	4.12	4.14	4.16	4.13
	Air Flow Rate	m ³ /min	600	600	600	667
	Fan Quantity	pcs	6	6	6	6
Sound Pressure Level	Static Pressure	Pa	110	110	110	110
	Normal Mode	dB(A)	65	65	66	66
	Night Shift Mode	dB(A)	50	50	51	51
Compressor	Type	Scroll Compressor				
	Quantity	pcs	3	3	3	3
Refrigerant	Type	R410A				
	Pre-charged Amount	kg	25.6	27.2	28.8	29.5
Weight	Net Weight	kg	273+273+296	273+296+296	296+296+296	296+296+316
	Gross Weight	kg	307+307+330	307+330+330	330+330+330	330+330+347
Dimensions	External(HxWxD)	mm	1730x (1210+1210+1210)	1730x (1210+1210+1210)	1730x (1210+1210+1210)	1730x (1210+1210+1350)
		mm	x750	x750	x750	x750
	Packing(HxWxD)	mm	1950x (1275+1275+1420)	1950x (1275+1420+1420)	1950x (1420+1420+1420)	1950x (1420+1420+1420)
		mm	x790	x790	x790	x790
Cabinet Color		Ivory White	Ivory White	Ivory White	Ivory White	
Ref. Piping	Gas	mm	φ41.3	φ41.3	φ41.3	φ41.3
		inch	1-5/8	1-5/8	1-5/8	1-5/8
	Liquid	mm	φ22.2	φ22.2	φ22.2	φ22.2
Connectable Indoor Units	inch	7/8	7/8	7/8	7/8	
	Quantity	pcs	64	64	64	64
Piping Design	Total Capacity	-	50%-150%	50%-150%	50%-150%	50%-150%
	Height Difference Between ODU and IDU	m(above)	50(90**)	50(90**)	50(90**)	50(90**)
		m(below)	40(90**)	40(90**)	40(90**)	40(90**)
	Height Difference Between IDUs	m	30	30	30	30
Max. Piping Length	m	1000	1000	1000	1000	
Operation Range*2	Cooling	DB	-5°C-52°C	-5°C-52°C	-5°C-52°C	-5°C-52°C
	Heating	WB	-25°C-16.5°C	-25°C-16.5°C	-25°C-16.5°C	-25°C-16.5°C

Notes:
 1. Rated capacity is tested in the following conditions:
 Pipe length: 7.5m, Pipe height difference: 0m; Cooling operation: indoor air inlet temperature 27°CDB 19°CWB, outdoor ambient temperature 35°CDB;
 Heating operation: indoor air inlet temperature 20°CDB, outdoor ambient temperature 7°CDB 6°CWB.
 2. The above noise values are measured in the anechoic chamber without reflected echo. Measurement point: 1 meter from the service cover surface and 1.5 meters from floor level.
 3. The above performance data is obtained on the basis of the performance of this outdoor unit, with a 100%-combination of 4-way cassette type indoor units.
 **: For height difference between ODU & IDU more than 50(40)m, please contact with our professional engineer.
 *: When the operation temperature is under 48°C DB ~ 52°C DB or -25°C WB ~ -20°C WB, the system may be in intermittent operation. Please contact with ur professional engineer.

Hi-FLEXi S mavo+ Series



HP		58HP	60HP	62HP	64HP	
Model	Model	AVWT-552HKFSEB	AVWT-572HKFSEB	AVWT-594HKFSEB	AVWT-614HKFSEB	
	Modules	AVWT-170HKFSEB	AVWT-170HKFSEB	AVWT-170HKFSEB	AVWT-190HKFSEB	
		AVWT-170HKFSEB	AVWT-190HKFSEB	AVWT-212HKFSEB	AVWT-212HKFSEB	
Power Supply		AC 3Φ, 380-415V/50/60Hz				
Cooling	Capacity	kW	161.5	167.5	173.0	179.0
		kBtu/h	551.0	571.5	590.3	610.7
	Power Input	kW	69.00	72.00	75.50	78.50
	EER	kW/kW	2.34	2.33	2.29	2.28
	SEER	kW/kW	6.31	6.30	6.21	6.20
Heating	Capacity (Max/Nom)	kW	181.0/161.5	188/167.5	194.0/173.0	201.0/179.0
		kBtu/h	617.6/551.0	641.5/571.5	661.9/590.3	685.8/610.7
	Power Input (Max/Nom)	kW	56.65/49.20	58.86/50.65	61.41/53.34	63.63/54.79
	COP (Max/Nom)	kW/kW	3.20/3.28	3.19/3.31	3.16/3.24	3.16/3.27
Ventilation	SCOP	kW/kW	4.12	4.09	4.08	4.06
	Air Flow Rate	m ³ /min	696	763	792	859
	Fan Quantity	pcs	6	6	6	6
Sound Pressure Level	Static Pressure	Pa	110	110	110	110
	Normal Mode	dB(A)	67	67	67	67
	Night Shift Mode	dB(A)	52	52	52	52
Compressor	Type	Scroll Compressor				
	Quantity	pcs	4	4	5	5
Refrigerant	Type	R410A				
	Pre-charged Amount	kg	31.4	32.1	34.0	34.7
Weight	Net Weight	kg	296+296+363	296+316+363	296+363+363	316+363+363
	Gross Weight	kg	330+330+400	330+347+400	330+400+400	347+400+400
Dimensions	External(HxWxD)	mm	1730x (1210+1210+1350)	1730x (1210+1350+1350)	1730x (1210+1350+1350)	1730x (1350+1350+1350)
		mm	x750	x750	x750	x750
	Packing(HxWxD)	mm	1950x (1420+1420+1420)	1950x (1420+1420+1420)	1950x (1420+1420+1420)	1950x (1420+1420+1420)
		mm	x790	x790	x790	x790
Cabinet Color		Ivory White	Ivory White	Ivory White	Ivory White	
Ref. Piping	Gas	mm	φ44.5	φ44.5	φ44.5	φ44.5
		inch	1-3/4	1-3/4	1-3/4	1-3/4
	Liquid	mm	φ22.2	φ22.2	φ22.2	φ22.2
Connectable Indoor Units	inch	7/8	7/8	7/8	7/8	
	Quantity	pcs	64	64	64	64
Piping Design	Total Capacity	-	50%-150%	50%-150%	50%-150%	50%-150%
	Height Difference Between ODU and IDU	m(above)	50(90**)	50(90**)	50(90**)	50(90**)
		m(below)	40(90**)	40(90**)	40(90**)	40(90**)
	Height Difference Between IDUs	m	30	30	30	30
Max. Piping Length	m	1000	1000	1000	1000	
Operation Range*2	Cooling	DB	-5°C-52°C	-5°C-52°C	-5°C-52°C	-5°C-52°C
	Heating	WB	-25°C-16.5°C	-25°C-16.5°C	-25°C-16.5°C	-25°C-16.5°C

Notes:
 1. Rated capacity is tested in the following conditions:
 Pipe length: 7.5m, Pipe height difference: 0m; Cooling operation: indoor air inlet temperature 27°CDB 19°CWB, outdoor ambient temperature 35°CDB;
 Heating operation: indoor air inlet temperature 20°CDB, outdoor ambient temperature 7°CDB 6°CWB.
 2. The above noise values are measured in the anechoic chamber without reflected echo. Measurement point: 1 meter from the service cover surface and 1.5 meters from floor level.
 3. The above performance data is obtained on the basis of the performance of this outdoor unit, with a 100%-combination of 4-way cassette type indoor units.
 **: For height difference between ODU & IDU more than 50(40)m, please contact with our professional engineer.
 *: When the operation temperature is under 48°C DB ~ 52°C DB or -25°C WB ~ -20°C WB, the system may be in intermittent operation. Please contact with ur professional engineer.

Hi-FLEXi S mavo+ Series



HP		66HP	68HP	70HP	72HP	
Model	Model	AVWT-636HKFSEB	AVWT-656HKFSEB	AVWT-676HKFSEB	AVWT-696HKFSEB	
	Modules	AVWT-212HKFSEB	AVWT-212HKFSEB	AVWT-212HKFSEB	AVWT-232HKFSEB	
		AVWT-212HKFSEB	AVWT-212HKFSEB	AVWT-232HKFSEB	AVWT-232HKFSEB	
		AVWT-212HKFSEB	AVWT-232HKFSEB	AVWT-232HKFSEB	AVWT-232HKFSEB	
Power Supply		AC 3Φ, 380-415V/50/60Hz				
Cooling	Capacity	kW 184.5	191.0	197.5	204.0	
		kBtu/h 629.5	651.7	673.9	696.0	
	Power Input	kW 82.00	85.03	88.05	91.08	
	EER	kW/kW 2.25	2.25	2.24	2.24	
	SEER	kW/kW 6.12	6.11	6.10	6.09	
Heating	Capacity (Max/Nom)	kW 207.0/184.5	213.0/191.0	219.0/197.5	225.0/204.0	
		kBtu/h 706.3/629.5	726.8/651.7	747.2/673.9	767.7/696.0	
	Power Input (Max/Nom)	kW 66.17/57.48	68.20/59.7	70.23/61.92	72.26/64.14	
	COP (Max/Nom)	kW/kW 3.13/3.21	3.12/3.20	3.12/3.19	3.11/3.18	
Ventilation	SCOP	kW/kW 4.05	4.00	3.96	3.93	
	Air Flow Rate	m³/min 888	942	996	1050	
	Fan Quantity	pcs 6	6	6	6	
	Static Pressure	Pa 110	110	110	110	
Sound Pressure Level	Normal Mode	dB(A) 68	68	68	69	
	Night Shift Mode	dB(A) 53	53	53	54	
Compressor	Type	Scroll Compressor				
	Quantity	pcs 6	6	6	6	
Refrigerant	Type	R410A				
	Pre-charged Amount	kg 36.6	36.4	36.2	36.0	
Weight	Net Weight	kg 363+363+363	363+363+391	363+391+391	391+391+391	
	Gross Weight	kg 400+400+400	400+400+433	400+433+433	433+433+433	
Dimensions	External(HxWxD)	mm 1730x	(1350+1350+1350)	(1350+1350+1600)	(1350+1600+1600)	
		x750	x750	x750	x750	
	Packing(HxWxD)	mm 1950x	(1420+1420+1420)	(1420+1420+1665)	(1420+1665+1665)	(1665+1665+1665)
		x790	x790	x790	x790	
Cabinet Color		Ivory White	Ivory White	Ivory White	Ivory White	
Ref. Piping	Gas	mm φ44.5	φ50.8	φ50.8	φ50.8	
		inch 1-3/4	2	2	2	
	Liquid	mm φ22.2	φ25.4	φ25.4	φ25.4	
inch 7/8		1	1	1		
Connectable Indoor Units	Quantity	pcs 64	64	64	64	
	Total Capacity	- 50%-150%	50%-150%	50%-150%	50%-150%	
Piping Design	Height Difference Between ODU and IDU	m(above) 50(90**)	50(90**)	50(90**)	50(90**)	
		m(below) 40(90**)	40(90**)	40(90**)	40(90**)	
	Height Difference Between IDUs	m 30	30	30	30	
		m 1000	1000	1000	1000	
Operation Range*2	Cooling	DB -5°C~52°C	-5°C~52°C	-5°C~52°C	-5°C~52°C	
	Heating	WB -25°C~16.5°C	-25°C~16.5°C	-25°C~16.5°C	-25°C~16.5°C	

Notes:
 1. Rated capacity is tested in the following conditions:
 Pipe length: 7.5m, Pipe height difference: 0m; Cooling operation: indoor air inlet temperature 27°CDB 19°CWB, outdoor ambient temperature 35°CDB;
 Heating operation: indoor air inlet temperature 20°CDB, outdoor ambient temperature 7°CDB 6°CWB.
 2. The above noise values are measured in the anechoic chamber without reflected echo. Measurement point: 1 meter from the service cover surface and 1.5 meters from floor level.
 3. The above performance data is obtained on the basis of the performance of this outdoor unit, with a 100%-combination of 4-way cassette type indoor units.
 *: For height difference between ODU & IDU more than 50(40)m, please contact with our professional engineer.
 **: When the operation temperature is under 48°C DB ~ 52°C DB or -25°C WB ~ -20°C WB, the system may be in intermittent operation. Please contact with ur professional engineer.

Hi-FLEXi S mavo+ Series



HP		74HP	76HP	78HP	80HP
Model	Model	AVWT-700HKFSEB	AVWT-720HKFSEB	AVWT-740HKFSEB	AVWT-760HKFSEB
	Modules	AVWT-170HKFSEB	AVWT-170HKFSEB	AVWT-170HKFSEB	AVWT-190HKFSEB
		AVWT-170HKFSEB	AVWT-170HKFSEB	AVWT-190HKFSEB	AVWT-190HKFSEB
		AVWT-170HKFSEB	AVWT-190HKFSEB	AVWT-190HKFSEB	AVWT-190HKFSEB
Power Supply		AC 3Φ, 380-415V/50/60Hz			
Cooling	Capacity	kW 206.0	212.0	218.0	224.0
		kBtu/h 702.9	723.3	743.8	764.3
	Power Input	kW 86.33	89.33	92.32	95.32
	EER	kW/kW 2.39	2.37	2.36	2.35
	SEER	kW/kW 6.42	6.40	6.39	6.37
Heating	Capacity (Max/Nom)	kW 231.0/206.0	238.0/212.0	245.0/218.0	252.0/224.0
		kBtu/h 788.2/702.9	812.1/723.3	835.9/743.8	859.8/764.3
	Power Input (Max/Nom)	kW 71.40/61.53	73.61/62.98	75.83/64.43	78.05/65.88
	COP (Max/Nom)	kW/kW 3.24/3.35	3.23/3.37	3.23/3.38	3.23/3.40
Ventilation	SCOP	kW/kW 4.14	4.11	4.09	4.07
	Air Flow Rate	m³/min 867	934	1001	1068
	Fan Quantity	pcs 8	8	8	8
	Static Pressure	Pa 110	110	110	110
Sound Pressure Level	Normal Mode	dB(A) 67	68	68	68
	Night Shift Mode	dB(A) 52	53	53	53
Compressor	Type	Scroll Compressor			
	Quantity	pcs 4	4	4	4
Refrigerant	Type	R410A			
	Pre-charged Amount	kg 39.1	39.8	40.5	41.2
Weight	Net Weight	kg 296+296+296+316	296+296+316+316	296+316+316+316	316+316+316+316
	Gross Weight	kg 330+330+330+347	330+330+347+347	330+347+347+347	347+347+347+347
Dimensions	External(HxWxD)	mm 1730x	(1210+1210+1210+1350)	(1210+1210+1350+1350)	(1210+1350+1350+1350)
		x750	x750	x750	x750
	Packing(HxWxD)	mm 1950x	(1420+1420+1420+1420)	(1420+1420+1420+1420)	(1420+1420+1420+1420)
		x790	x790	x790	x790
Cabinet Color		Ivory White	Ivory White	Ivory White	Ivory White
Ref. Piping	Gas	mm φ50.8	φ50.8	φ50.8	φ50.8
		inch 2	2	2	2
	Liquid	mm φ25.4	φ25.4	φ25.4	φ25.4
inch 1		1	1	1	
Connectable Indoor Units	Quantity	pcs 64	64	64	64
	Total Capacity	- 50%-150%	50%-150%	50%-150%	50%-150%
Piping Design	Height Difference Between ODU and IDU	m(above) 50(90**)	50(90**)	50(90**)	50(90**)
		m(below) 40(90**)	40(90**)	40(90**)	40(90**)
	Height Difference Between IDUs	m 30	30	30	30
		m 1000	1000	1000	1000
Operation Range*2	Cooling	DB -5°C~52°C	-5°C~52°C	-5°C~52°C	-5°C~52°C
	Heating	WB -25°C~16.5°C	-25°C~16.5°C	-25°C~16.5°C	-25°C~16.5°C

Notes:
 1. Rated capacity is tested in the following conditions:
 Pipe length: 7.5m, Pipe height difference: 0m; Cooling operation: indoor air inlet temperature 27°CDB 19°CWB, outdoor ambient temperature 35°CDB;
 Heating operation: indoor air inlet temperature 20°CDB, outdoor ambient temperature 7°CDB 6°CWB.
 2. The above noise values are measured in the anechoic chamber without reflected echo. Measurement point: 1 meter from the service cover surface and 1.5 meters from floor level.
 3. The above performance data is obtained on the basis of the performance of this outdoor unit, with a 100%-combination of 4-way cassette type indoor units.
 *: For height difference between ODU & IDU more than 50(40)m, please contact with our professional engineer.
 **: When the operation temperature is under 48°C DB ~ 52°C DB or -25°C WB ~ -20°C WB, the system may be in intermittent operation. Please contact with ur professional engineer.

Hi-FLEXi S mavo+ Series



HP		82HP	84HP	86HP	88HP
Model	Model	AVWT-782HKFSEB	AVWT-804HKFSEB	AVWT-826HKFSEB	AVWT-848HKFSEB
	Modules	AVWT-190HKFSEB	AVWT-190HKFSEB	AVWT-190HKFSEB	AVWT-212HKFSEB
		AVWT-190HKFSEB	AVWT-190HKFSEB	AVWT-212HKFSEB	AVWT-212HKFSEB
		AVWT-190HKFSEB	AVWT-212HKFSEB	AVWT-212HKFSEB	AVWT-212HKFSEB
		AVWT-212HKFSEB	AVWT-212HKFSEB	AVWT-212HKFSEB	AVWT-212HKFSEB
Power Supply		AC 3φ, 380-415V/50/60Hz			
Cooling	Capacity	kW 229.5	235.0	240.5	246.0
		kBtu/h 783.1	801.8	820.6	839.4
	Power Input	kW 98.82	102.33	105.83	109.33
	EER	kW/kW 2.32	2.30	2.27	2.25
	SEER	kW/kW 6.30	6.24	6.18	6.12
Heating	Capacity (Max/Nom)	kW 258.0/229.5	264.0/235.0	270.0/240.5	276.0/246.0
		kBtu/h 880.3/783.1	900.8/801.8	921.2/820.6	941.7/839.4
	Power Input (Max/Nom)	kW 80.59/68.57	83.14/71.26	85.68/73.95	88.23/76.64
	COP (Max/Nom)	kW/kW 3.20/3.35	3.18/3.30	3.15/3.25	3.13/3.21
	SCOP	kW/kW 4.07	4.06	4.05	4.05
Ventilation	Air Flow Rate	m³/min 1097	1126	1155	1184
	Fan Quantity	pcs 8	8	8	8
	Static Pressure	Pa 110	110	110	110
Sound Pressure Level	Normal Mode	dB(A) 68	69	69	69
	Night Shift Mode	dB(A) 53	54	54	54
Compressor	Type	Scroll Compressor			
	Quantity	pcs 5	6	7	8
Refrigerant	Type	R410A			
	Pre-charged Amount	kg 43.1	45.0	46.9	48.8
Weight	Net Weight	kg 316+316+316+363	316+316+363+363	316+363+363+363	363+363+363+363
	Gross Weight	kg 347+347+347+400	347+347+400+400	347+400+400+400	400+400+400+400
Dimensions	External(HxWxD)	mm 1730x	(1350+1350+1350+1350)	(1350+1350+1350+1350)	(1350+1350+1350+1350)
		x750	x750	x750	x750
	Packing(HxWxD)	mm 1950x	(1420+1420+1420+1420)	(1420+1420+1420+1420)	(1420+1420+1420+1420)
		x790	x790	x790	x790
Cabinet Color		Ivory White	Ivory White	Ivory White	Ivory White
Ref. Piping	Gas	mm φ50.8	φ50.8	φ50.8	φ50.8
		inch 2	2	2	2
	Liquid	mm φ25.4	φ25.4	φ25.4	φ25.4
inch 1		1	1	1	
Connectable Indoor Units	Quantity	pcs 64	64	64	64
	Total Capacity	— 50%~150%	50%~150%	50%~150%	50%~150%
Piping Design	Height Difference Between ODU and IDU	m(above) 50(90**)	50(90**)	50(90**)	50(90**)
		m(below) 40(90**)	40(90**)	40(90**)	40(90**)
	Height Difference Between IDUs	m 30	30	30	30
		m 1000	1000	1000	1000
Operation Range*2	Cooling	DB -5°C~52°C	-5°C~52°C	-5°C~52°C	-5°C~52°C
	Heating	WB -25°C~16.5°C	-25°C~16.5°C	-25°C~16.5°C	-25°C~16.5°C

- Notes:
- Rated capacity is tested in the following conditions:
Pipe length: 7.5m, Pipe height difference: 0m; Cooling operation: indoor air inlet temperature 27°CDB 19°CWB, outdoor ambient temperature 35°CDB;
Heating operation: indoor air inlet temperature 20°CDB, outdoor ambient temperature 7°CDB 6°CWB.
 - The above noise values are measured in the anechoic chamber without reflected echo. Measurement point: 1 meter from the service cover surface and 1.5 meters from floor level.
 - The above performance data is obtained on the basis of the performance of this outdoor unit, with a 100%-combination of 4-way cassette type indoor units.
*: For height difference between ODU & IDU more than 50(40)m, please contact with our professional engineer.
*: When the operation temperature is under 48°C DB ~ 52°C DB or -25°C WB ~ -20°C WB, the system may be in intermittent operation. Please contact with ur professional engineer.

Hi-FLEXi S mavo+ Series



HP		90HP	92HP	94HP	96HP
Model	Model	AVWT-868HKFSEB	AVWT-888HKFSEB	AVWT-908HKFSEB	AVWT-928HKFSEB
	Modules	AVWT-212HKFSEB	AVWT-212HKFSEB	AVWT-212HKFSEB	AVWT-232HKFSEB
		AVWT-212HKFSEB	AVWT-212HKFSEB	AVWT-232HKFSEB	AVWT-232HKFSEB
		AVWT-212HKFSEB	AVWT-232HKFSEB	AVWT-232HKFSEB	AVWT-232HKFSEB
		AVWT-232HKFSEB	AVWT-232HKFSEB	AVWT-232HKFSEB	AVWT-232HKFSEB
Power Supply		AC 3φ, 380-415V/50/60Hz			
Cooling	Capacity	kW 252.5	259.0	265.5	272.0
		kBtu/h 861.5	883.7	905.9	928.1
	Power Input	kW 112.36	115.39	118.41	121.44
	EER	kW/kW 2.25	2.24	2.24	2.24
	SEER	kW/kW 6.11	6.10	6.10	6.09
Heating	Capacity (Max/Nom)	kW 282.0/252.5	288.0/259.0	294.0/265.5	300.0/272.0
		kBtu/h 962.2/861.5	982.7/883.7	1003.1/905.9	1023.6/928.1
	Power Input (Max/Nom)	kW 90.26/78.86	92.29/81.08	94.32/83.30	96.35/85.52
	COP (Max/Nom)	kW/kW 3.12/3.20	3.12/3.19	3.12/3.19	3.11/3.18
	SCOP	kW/kW 4.01	3.98	3.95	3.93
Ventilation	Air Flow Rate	m³/min 1238	1292	1346	1400
	Fan Quantity	pcs 8	8	8	8
	Static Pressure	Pa 110	110	110	110
Sound Pressure Level	Normal Mode	dB(A) 69	70	70	70
	Night Shift Mode	dB(A) 54	55	55	55
Compressor	Type	Scroll Compressor			
	Quantity	pcs 8	8	8	8
Refrigerant	Type	R410A			
	Pre-charged Amount	kg 48.6	48.4	48.2	48.0
Weight	Net Weight	kg 363+363+363+391	363+363+391+391	363+391+391+391	391+391+391+391
	Gross Weight	kg 400+400+400+433	400+400+433+433	400+433+433+433	433+433+433+433
Dimensions	External(HxWxD)	mm 1730x	(1350+1350+1350+1600)	(1350+1350+1600+1600)	(1350+1600+1600+1600)
		x750	x750	x750	x750
	Packing(HxWxD)	mm 1950x	(1420+1420+1420+1665)	(1420+1420+1665+1665)	(1420+1665+1665+1665)
		x790	x790	x790	x790
Cabinet Color		Ivory White	Ivory White	Ivory White	Ivory White
Ref. Piping	Gas	mm φ50.8	φ50.8	φ50.8	φ50.8
		inch 2	2	2	2
	Liquid	mm φ25.4	φ25.4	φ25.4	φ25.4
inch 1		1	1	1	
Connectable Indoor Units	Quantity	pcs 64	64	64	64
	Total Capacity	— 50%~150%	50%~150%	50%~150%	50%~150%
Piping Design	Height Difference Between ODU and IDU	m(above) 50(90**)	50(90**)	50(90**)	50(90**)
		m(below) 40(90**)	40(90**)	40(90**)	40(90**)
	Height Difference Between IDUs	m 30	30	30	30
		m 1000	1000	1000	1000
Operation Range*2	Cooling	DB -5°C~52°C	-5°C~52°C	-5°C~52°C	-5°C~52°C
	Heating	WB -25°C~16.5°C	-25°C~16.5°C	-25°C~16.5°C	-25°C~16.5°C

- Notes:
- Rated capacity is tested in the following conditions:
Pipe length: 7.5m, Pipe height difference: 0m; Cooling operation: indoor air inlet temperature 27°CDB 19°CWB, outdoor ambient temperature 35°CDB;
Heating operation: indoor air inlet temperature 20°CDB, outdoor ambient temperature 7°CDB 6°CWB.
 - The above noise values are measured in the anechoic chamber without reflected echo. Measurement point: 1 meter from the service cover surface and 1.5 meters from floor level.
 - The above performance data is obtained on the basis of the performance of this outdoor unit, with a 100%-combination of 4-way cassette type indoor units.
*: For height difference between ODU & IDU more than 50(40)m, please contact with our professional engineer.
*: When the operation temperature is under 48°C DB ~ 52°C DB or -25°C WB ~ -20°C WB, the system may be in intermittent operation. Please contact with ur professional engineer.

Hi-Smart Series

High Efficiency

The outdoor unit features a new generation of wide-diameter fans, with the fan diameter increased from 544mm to 700mm (600mm for single-fan unit). This upgrade results in a 44% increase in airflow at the same rotational speed, enhancing energy efficiency at lower speeds and boosting cooling capacity at higher speeds. Additionally, the unit is equipped with a DC inverter motor that enables precise speed control, ensuring stable and efficient operation.

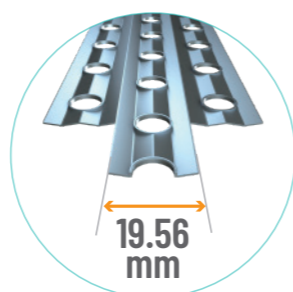

Advanced corrugated fin

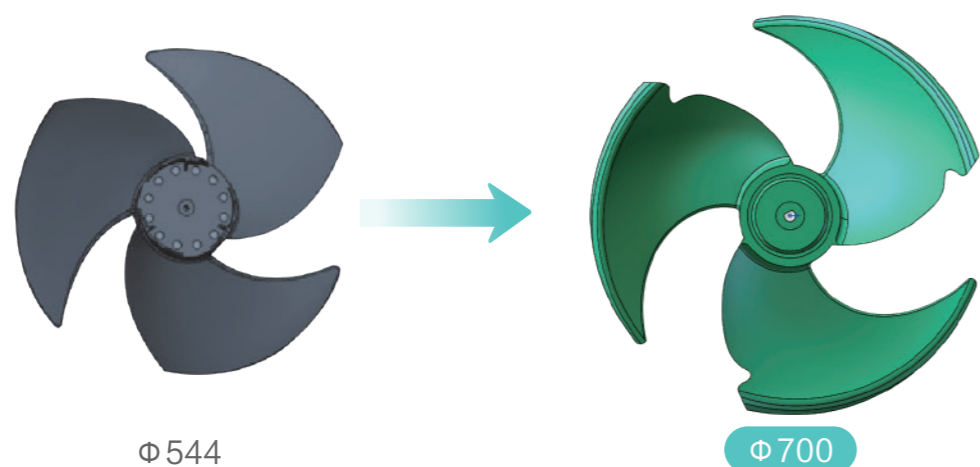

Eco-friendly R32 Refrigerant

R32 refrigerant contributes to meeting the F-gas regulation targets as described in EU regulation 517/2014. Hisense HVAC introduces the Lower GWP refrigerant R32 on its VRF products, which is a perfect solution for attaining the CO₂ emission targets.

Features

- Zero Ozone Depletion Potential (ODP)
- Lower Global Warming Potential (GWP)
- Less charge amount under the same capacity
- Single component refrigerant, easy to handle and recycle



Less refrigerant, less CO₂-EQ emissions

By using the R32 refrigerant with a low Global Warming Potential (GWP) and the Hi-Smart H5 system's reduced refrigerant charge, the overall CO₂ equivalent emissions can be lowered by 76% compared to the traditional R410A products.

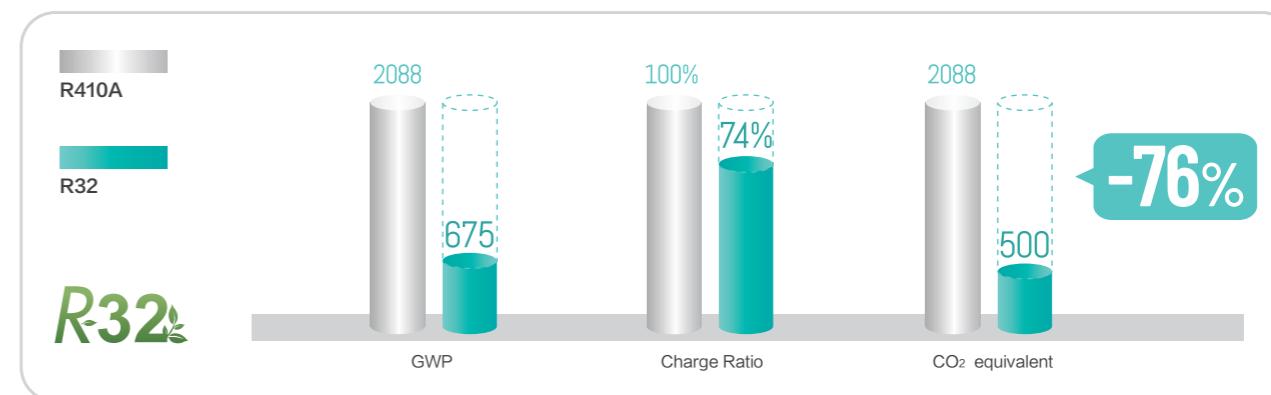

Multiple Measures Ensuring Room Safety

Refrigerant Leakage Detection

Real-time refrigerant leakage detection is essential for R32 refrigerant system. If the refrigerant concentration exceeds 5000ppm, the indoor unit will stop operation, and trigger the audible and visual alarm. It can also be linked to any third-party alarm system or ventilation system.

Refrigerant Recovery

In the event of a refrigerant leak, our system triggers alarms and shuts down. If the leak occurs in an indoor unit that exceeds the safe capacity, the system immediately activates refrigerant recovery. Furthermore, in the event of a sudden power outage, the shut-off box automatically closes the valves to prevent leaks.

The Progress of Refrigerant Recovery

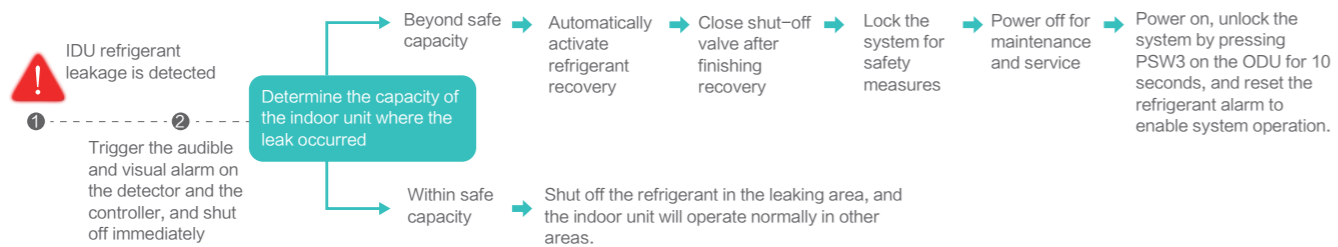

Slim and Compact Footprint

The H5 unit, with its smaller footprint and compact body compared to the last generation S Series top-flow unit for the same capacity, enables the utilization of the saved rooftop space for a green roof. This enhances the building's aesthetics.

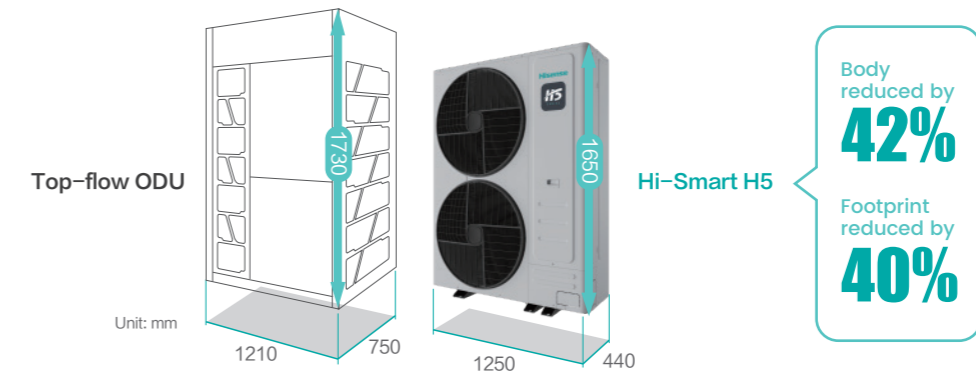

Anywhere & Everywhere

Thanks to its slim modular design, H5 offers unrivaled flexibility of installation location. Save your building's most valuable area, and place H5 in the small narrow spaces of your building. On the rooftop, balcony, or indoors; you choose!



Backup Operation for Emergencies

When two H5 modules are combined, the backup operation function ensures the system won't come to a complete stop in the event of an outdoor unit failure. The unit can provide up to five backups, allowing the system to continue operating with the remaining module until service and repair are completed.

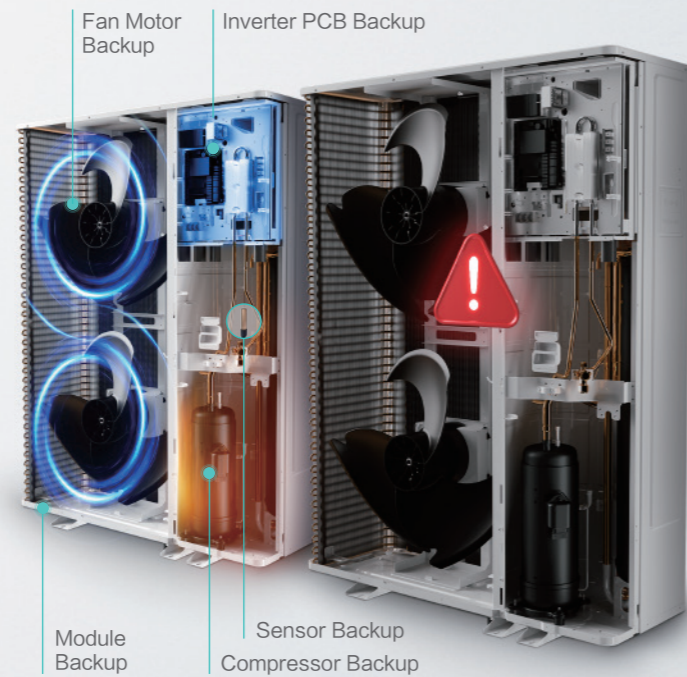

Dust-cleaning Technology

Keep your air conditioner performing at its best with Hi-Smart H5's innovative dust-cleaning technology. Our outdoor fan reverses direction to efficiently remove accumulated dust, reducing air resistance and maintaining optimal heat exchange. Experience uninterrupted comfort for the long run with Hi-Smart H5.

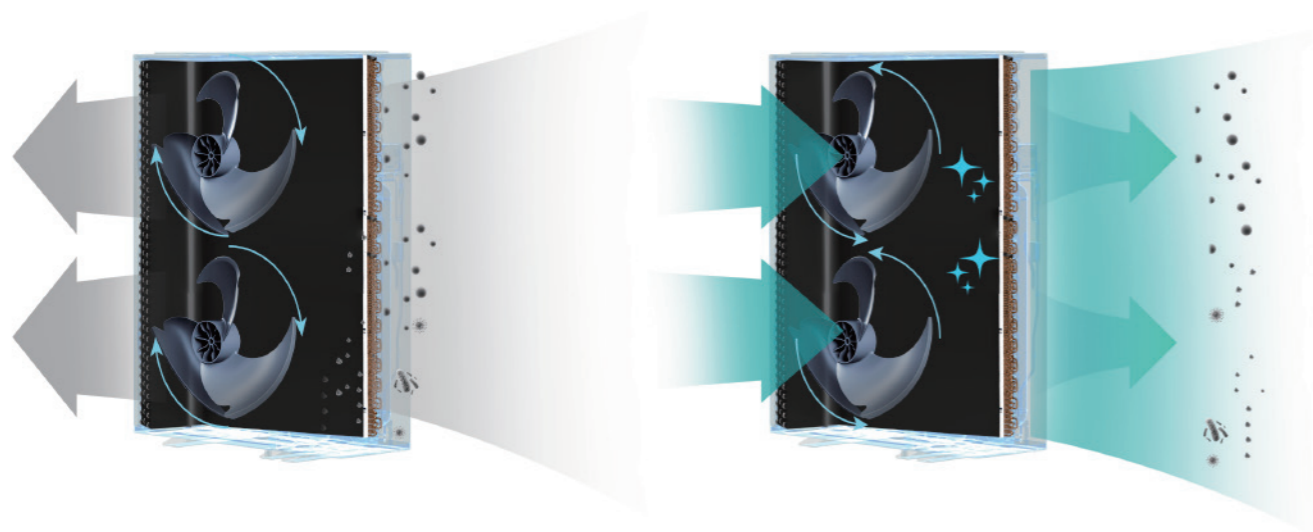

Hi-Smart H5 Series



		HP	4HP	5HP	6HP
Model	AC 1 φ, 220-240V/50/60Hz		AVW-41HJDH2H1	AVW-48HJDH2H1	AVW-54HJDH2H1
	AC 3 φ, 380-415V/50/60Hz		AVW-41HKDH2H1	AVW-48HKDH2H1	AVW-54HKDH2H1
Cooling	Capacity	kW	12.1	14.0	15.5
		kBtu/h	41.5	48.0	53.0
	Power Input	kW	3.30	4.24	4.70
	EER	kW/kW	3.67	3.30	3.30
	SEER	kW/kW	8.20	7.90	7.90
Heating	Capacity (Max/Nom)	kW	14.2/12.1	16.0/14.0	18.0/15.5
		kBtu/h	48.0/41.5	54.5/48.0	61.5/53.0
	Power Input (Max/Nom)	kW	3.60/2.63	4.10/3.18	4.80/3.52
	COP (Max/Nom)	kW/kW	3.94/4.60	3.90/4.40	3.75/4.40
	SCOP	kW/kW	5.00	4.65	4.60
Air Flow Rate		m ³ /min	80	80	80
Sound Pressure Level (Cooling/Heating)		dB(A)	52/52	53/53	54/54
Refrigerant	Type			R32	
	Pre-charged Quantity	kg	2	2	2
Weight	Net Weight (Single-phase/Three-phase)	kg	94/95	94/95	94/95
	Gross Weight (Single-phase/Three-phase)	kg	109/110	109/110	109/110
Dimensions	Net (H × W × D)	mm	840 × 1100 × 390	840 × 1100 × 390	840 × 1100 × 390
	Packing (H × W × D)	mm	1000 × 1185 × 530	1000 × 1185 × 530	1000 × 1185 × 530
Cabinet Color			Grayish White	Grayish White	Grayish White
Ref. Piping	Gas	mm	15.88	15.88	15.88
		inch	5/8	5/8	5/8
	Liquid	mm	9.53	9.53	9.53
		inch	3/8	3/8	3/8
Connectable Indoor Units	Quantity	pcs	10	12	13
	Connection Ratio		50%~150%	50%~150%	50%~150%
Piping Design	Max. Piping Length	m	80	80	80
	Height Difference Between ODU and IDU	m (OD higher)	50	50	50
		m (OD lower)	40	40	40
	Height Difference Between IDUs	m	15	15	15
Operation Range	Cooling	DB °C		-10 ~ 52	
	Heating	WB/DB °C		-25.5 ~ 15.5 / -25 ~ 26	

Note:

1. Rated cooling capacity and rated heating capacity are tested in the following conditions:

Cooling conditions: indoor air inlet temperature: 27°C DB 19°C WB, outdoor air inlet temperature: 35°C DB, pipe length: 7.5m, pipe height difference: 0m.
 Heating conditions: indoor air inlet temperature: 20°C DB, outdoor air inlet temperature: 7°C DB 6°C WB, pipe length: 7.5m, pipe height difference: 0m.

2. During cooling (48~52°C) or heating (23~26°C) operations, the unit may operate intermittently.

3. The above performance data is obtained on the basis of the performance of this outdoor unit, with a 100% combination of 4-way cassette indoor units.

Hi-Smart H5 Series

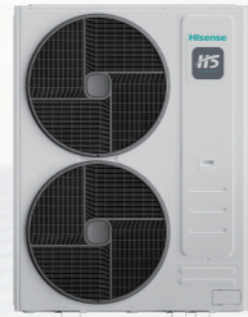

HP		8HP	10HP	12HP	14HP	16HP	
Model		AVW-76HKDHE2	AVW-96HKDHE2	AVW-114HKDHE2	AVW-136HKDHE2	AVW-154HKDHE2	
Combination		/	/	/	/	/	
Power Supply		AC 3Φ, 380-415V/50/60Hz					
Cooling	Capacity	kW	22.4	28.0	33.5	40.0	45.0
		kBtu/h	76.4	95.5	114.3	136.5	153.5
	Power Input	kW	5.89	7.57	9.31	11.43	13.24
	EER	kW/kW	3.80	3.70	3.60	3.50	3.40
	SEER	-	7.97	8.57	8.53	7.57	7.43
Heating	Capacity (Max./Nom.)	kW	25.0/22.4	31.5/28.0	37.5/33.5	45.0/40.0	50.0/45.0
		kBtu/h	85.3/76.4	107.5/95.5	127.9/114.3	153.5/136.5	170.6/153.5
	Power Input (Max./Nom.)	kW	5.32/4.57	7.00/5.96	9.15/7.70	10.98/9.30	12.20/10.71
	COP (Max./Nom.)	kW/kW	4.70/4.90	4.50/4.70	4.10/4.35	4.10/4.30	4.10/4.20
	SCOP	-	5.50	4.80	4.89	4.75	4.85
Air Flow Rate	m ³ /min	212	212	212	287	287	
Sound Pressure Level (Cooling/Heating)	dB(A)	54/57	55/58	55/58	61/62	62/65	
Refrigerant	Type	R32					
	Pre-charged Quantity	kg	4.0	4.5	5.7	6.0	6.0
Weight	Net Weight	kg	191	192	193	215	216
	Gross Weight	kg	209	210	211	233	234
Dimensions	Net (H × W × D)	mm 1650 × 1250 × 440					
	Packing (H × W × D)	mm 1810 × 1350 × 580					
Cabinet Color		Grayish White					
Ref. Piping	Gas	mm	22.2	22.2	25.4	25.4	28.6
		inch	7/8	7/8	8/8	8/8	9/8
	Liquid	mm	9.53	9.53	12.7	12.7	12.7
		inch	3/8	3/8	4/8	4/8	4/8
Connectable Indoor Units	Quantity	pcs	17	21	26	31	34
	Connection Ratio	-	30%~200%				
Piping Design	Total Piping Length	m	500	500	500	500	500
	Max. piping Length	m (Actual)	150	150	150	150	150
		m (Equivalent)	165	165	165	165	165
	Height difference between ODU and IDU	m (ODU Up)	50	50	50	50	50
		m (ODU Down)	40	40	40	40	40
Height Difference Between IDUs	m	40	40	40	40	40	
Operation Range	Cooling	DB	-10~55°C				
	Heating	WB/DB	-25~-16.5°C/-24~-23°C				

- Notes:
- Rated cooling capacity and rated heating capacity are tested in the following conditions:
Cooling Conditions: indoor air inlet temperature: 27°C DB 19°C WB, outdoor air inlet temperature: 35°C DB, pipe length: 7.5m, pipe height difference: 0m.
Heating Conditions: indoor air inlet temperature: 20°C DB, outdoor air inlet temperature: 7°C DB 6°C WB, pipe Length: 7.5m, pipe height difference: 0m.
 - The above performance data is obtained on the basis of the performance of this outdoor unit, with a 100%-combination of 4-Way Cassette indoor units.
 - The above noise values are measured in the anechoic chamber without reflected echo, therefore the impact of the reflected echo must be included at the scene.
Measurement point: 1m from the service cover surface and 0.92m from the floor level.
 - The final appearance of outdoor units is subject to the actual products.
 - The dip switch DSW1-4 of outdoor PCB must set ON. This value is measured from the air outlet grille of the outdoor unit.
 - Under cooling operation, where the temperature is higher than 52°C, the system may work under intermittent operation.
 - A connection ratio of 30%~50% is suitable for phased installation, and 150%~200% is for cooling-only applications.
- *1 If you have any questions, please contact with the technical engineer.

Hi-Smart H5 Series

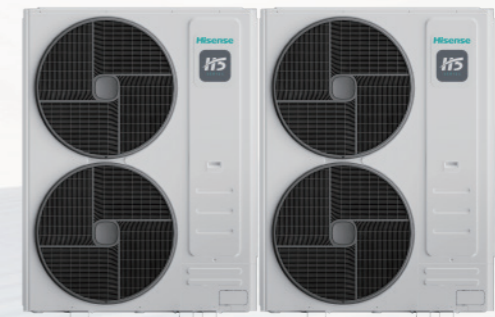

HP		18HP	20HP	22HP	24HP	
Model		AVW-170HKDHE2	AVW-190HKDHE2	AVW-212HKDHE2	AVW-232HKDHE2	
Combination		AVW-76HKDHE2	AVW-96HKDHE2	AVW-96HKDHE2	AVW-114HKDHE2	
		AVW-96HKDHE2	AVW-96HKDHE2	AVW-114HKDHE2	AVW-114HKDHE2	
Power Supply		AC 3Φ, 380-415V/50/60Hz				
Cooling	Capacity	kW	50.4	56.0	61.5	67.0
		kBtu/h	171.9	191.0	209.8	228.6
	Power Input	kW	13.5	15.1	16.9	18.6
	EER	kW/kW	3.74	3.70	3.64	3.60
	SEER	kW/kW	8.29	8.57	8.55	8.53
Heating	Capacity (Max./Nom.)	kW	56.5/50.4	63.0/56.0	69.0/61.5	75.0/67.0
		kBtu/h	192.8/171.9	215.0/191.0	235.4/209.8	255.9/228.6
	Power Input (Max./Nom.)	kW	12.3/10.5	14.0/11.9	16.1/13.7	18.3/15.4
	COP (Max./Nom.)	kW/kW	4.59/4.79	4.50/4.70	4.27/4.50	4.10/4.35
	SCOP	kW/kW	5.09	4.80	4.85	4.89
Air Flow Rate	m ³ /min	424	424	424	424	
Sound Pressure Level (Cooling/Heating)	dB(A)	55/58	55/58	55/58	55/58	
Refrigerant	Type	R32				
	Pre-charged Quantity	kg	9	9	10	11
Weight	Net Weight	kg	383	384	385	386
	Gross Weight	kg	419	420	421	422
Dimensions	Net (H × W × D)	mm 1650 × 1250 × 440				
	Packing (H × W × D)	mm 1810 × 1350 × 580				
Cabinet Color		Grayish White				
Ref. Piping	Gas	mm	28.6	28.6	28.6	28.6
		inch	9/8	9/8	9/8	9/8
	Liquid	mm	15.88	15.88	15.88	15.88
		inch	5/8	5/8	5/8	5/8
Connectable Indoor Units	Quantity	pcs	36	40	44	48
	Connection Ratio	-	30%~200%			
Piping Design	Total Piping Length	m	500	500	500	500
	Max. piping Length	m (Actual)	150	150	150	150
		m (Equivalent)	165	165	165	165
	Height difference between ODU and IDU	m (ODU Up)	50	50	50	50
		m (ODU Down)	40	40	40	40
Height Difference Between IDUs	m	40	40	40	40	
Operation Range	Cooling	DB	-10~55°C			
	Heating	WB/DB	-25~-16.5°C/-24~-23°C			

- Notes:
- Rated cooling capacity and rated heating capacity are tested in the following conditions:
Cooling Conditions: indoor air inlet temperature: 27°C DB 19°C WB, outdoor air inlet temperature: 35°C DB, pipe length: 7.5m, pipe height difference: 0m.
Heating Conditions: indoor air inlet temperature: 20°C DB, outdoor air inlet temperature: 7°C DB 6°C WB, pipe Length: 7.5m, pipe height difference: 0m.
 - The above performance data is obtained on the basis of the performance of this outdoor unit, with a 100%-combination of 4-Way Cassette indoor units.
 - The above noise values are measured in the anechoic chamber without reflected echo, therefore the impact of the reflected echo must be included at the scene.
Measurement point: 1m from the service cover surface and 0.92m from the floor level.
 - The final appearance of outdoor units is subject to the actual products.
 - The dip switch DSW1-4 of outdoor PCB must set ON. This value is measured from the air outlet grille of the outdoor unit.
 - Under cooling operation, where the temperature is higher than 52°C, the system may work under intermittent operation.
 - A connection ratio of 30%~50% is suitable for phased installation, and 150%~200% is for cooling-only applications.
- *1 If you have any questions, please contact with the technical engineer.

Hi-Smart H5 Series

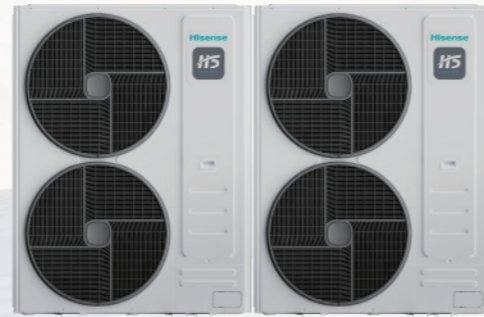

HP		26HP	28HP	30HP	32HP	
Model		AVW-250HKDHE2	AVW-272HKDHE2	AVW-290HKDHE2	AVW-308HKDHE2	
Combination		AVW-114HKDHE2	AVW-136HKDHE2	AVW-136HKDHE2	AVW-154HKDHE2	
		AVW-136HKDHE2	AVW-136HKDHE2	AVW-154HKDHE2	AVW-154HKDHE2	
Power Supply		AC 3Φ, 380-415V/50/60Hz				
Cooling	Capacity	kW	73.5	80.0	85.0	90.0
		kBtu/h	250.8	273.0	290.0	307.0
	Power Input	kW	20.7	22.9	24.7	26.5
	EER	kW/kW	3.54	3.50	3.45	3.40
	SEER	kW/kW	7.98	7.57	7.50	7.43
Heating	Capacity (Max./Nom.)	kW	82.5/73.5	90.0/80.0	95.0/85.0	100.0/90.0
		kBtu/h	281.5/250.8	307.1/273.0	324.2/290.0	341.2/307.0
	Power Input (Max./Nom.)	kW	20.1/17.0	22.0/18.6	23.2/20.0	24.4/21.4
	COP (Max./Nom.)	kW/kW	4.10/4.32	4.10/4.30	4.10/4.25	4.10/4.20
	SCOP	kW/kW	4.81	4.75	4.80	4.85
Air Flow Rate	m³/min	499	574	574	574	
Sound Pressure Level (Cooling/Heating)	dB(A)	59/60	61/62	62/64	62/65	
Refrigerant	Type	R32				
	Pre-charged Quantity	kg	12	12	12	12
Weight	Net Weight	kg	408	430	431	432
	Gross Weight	kg	444	466	467	468
Dimensions	Net (H × W × D)	mm 1650 × 1250 × 440				
	Packing (H × W × D)	mm 1810 × 1350 × 580				
Cabinet Color		Grayish White				
Ref. Piping	Gas	mm	31.75	31.75	31.75	31.75
		inch	10/8	10/8	10/8	10/8
	Liquid	mm	19.05	19.05	19.05	19.05
		inch	6/8	6/8	6/8	6/8
Connectable Indoor Units	Quantity	pcs	52	56	60	64
	Connection Ratio	-	30% - 200%			
Piping Design	Total Piping Length	m	500	500	500	500
	Max. piping Length	m (Actual)	150	150	150	150
		m (Equivalent)	165	165	165	165
	Height difference between ODU and IDU	m (ODU Up)	50	50	50	50
		m (ODU Down)	40	40	40	40
	Height Difference Between IDUs	m	40	40	40	40
Operation Range	Cooling	DB	-10-55°C			
	Heating	WB/DB	-25-16.5°C/-24-23°C			

- Notes:
- Rated cooling capacity and rated heating capacity are tested in the following conditions:
Cooling Conditions: indoor air inlet temperature: 27°C DB 19°C WB, outdoor air inlet temperature: 35°C DB, pipe length: 7.5m, pipe height difference: 0m.
Heating Conditions: indoor air inlet temperature: 20°C DB, outdoor air inlet temperature: 7°C DB 6°C WB, pipe length: 7.5m, pipe height difference: 0m.
 - The above performance data is obtained on the basis of the performance of this outdoor unit, with a 100%-combination of 4-Way Cassette indoor units.
 - The above noise values are measured in the anechoic chamber without reflected echo, therefore the impact of the reflected echo must be included at the scene.
Measurement point: 1m from the service cover surface and 0.92m from the floor level.
 - The final appearance of outdoor units is subject to the actual products.
 - The dip switch DSW1-4 of outdoor PCB must set ON. This value is measured from the air outlet grille of the outdoor unit.
 - Under cooling operation, where the temperature is higher than 52°C, the system may work under intermittent operation.
 - A connection ratio of 30-50% is suitable for phased installation, and 150-200% is for cooling-only applications.
- *1 If you have any questions, please contact with the technical engineer.

Hi-Smart Series



Dust-cleaning Technology

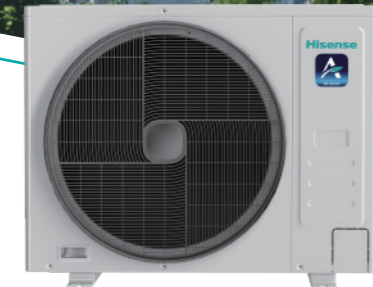

Keep your air conditioner performing at its best with Hi-Smart A's innovative dust-cleaning technology. Our outdoor fan reverses direction to efficiently remove accumulated dust, reducing air resistance and maintaining optimal heat exchange. Experience uninterrupted comfort for the long run with Hi-Smart A.

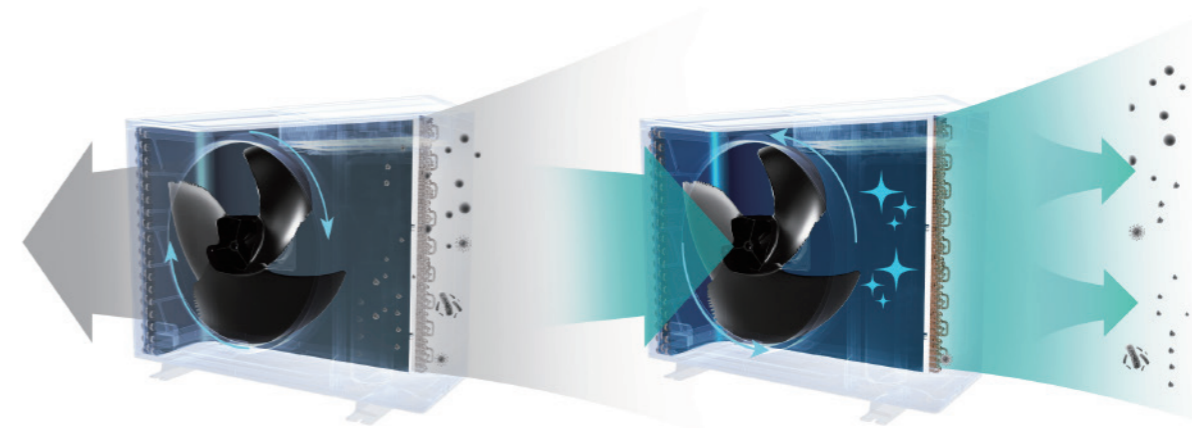

1W Standby Power Consumption

Hi-Smart A series uses optimized control scheme to further reduce standby power consumption to as low as 1W. The system intelligently enters 1W standby mode when the air conditioner is not in frequent use to avoid unnecessary waste.



Transition season



Leave home for a short time



Electromagnetic Heating Technology

Hisense's innovative internal electromagnetic heating technology is used without external heating tape. The lubricating oil is heated by the compressor's fixed rotor for higher heating efficiency, significantly reducing the low-temperature preheating time and power consumption.

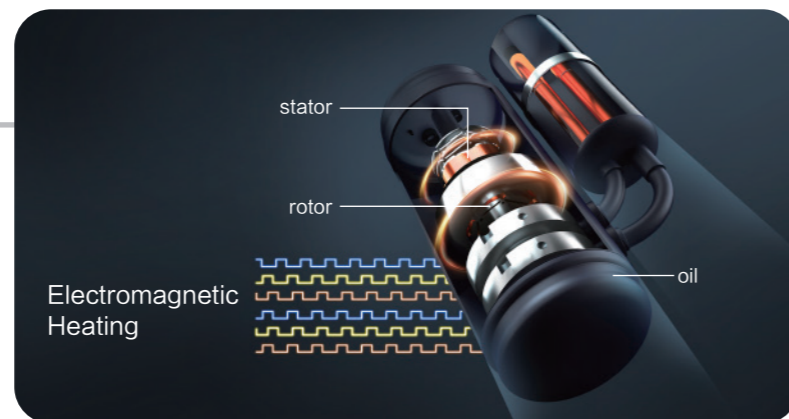

Compact Size for Space-saving

With its compact size, the Hi-Smart A system outdoor unit take up less space to make your balcony or backyard for other essentials.

In addition, the mini VRF A-Series outdoor units require only a pair of pipes to connect to multiple indoor units , which reduces damage to walls and makes buildings more aesthetically pleasing.

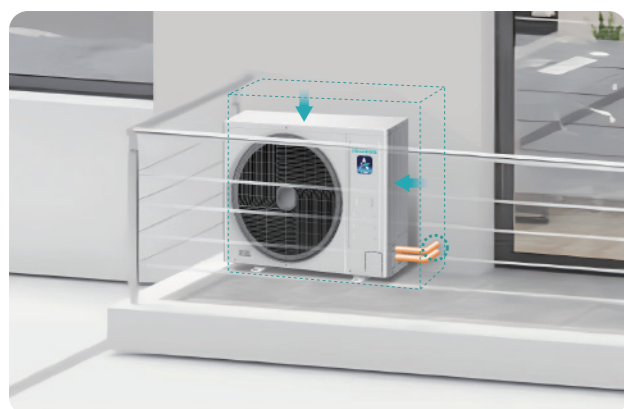

Mini VRF

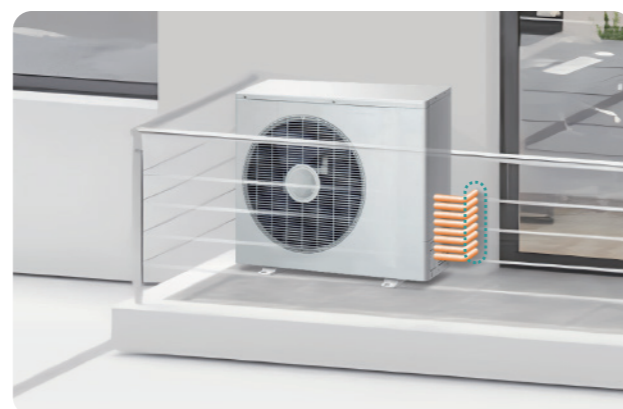

Multi split

Four-way Piping Connection

Installation restrictions on site do not stop Hi-Smart A mini VRF with flexible piping directions.including front, bottom, right, and rearconnections.



Flexible Air Discharge Directions

When the ODU is installed in narrow spaces where some obstacle blocks discharged air, the well-designed air outlet guide can divert the airflow to up, down, left, or right directions to enhance the heat dissipation efficiency.

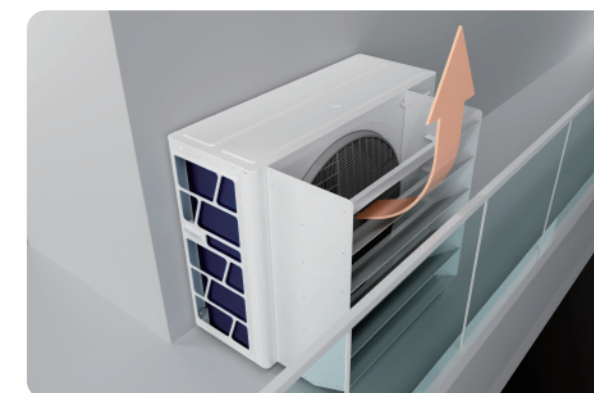

Note: Air outlet guide module SH-76CD/SH-34CD

Long Piping for Design Flexibility

The Hi-Smart A provides long piping length possibility of 75m, with a total piping length of 120m. The height difference between IDU and ODU can be up to a maximum of 30m. These generous allowances facilitate system designs compared to the Multi-split system.

- ① Max.piping length: 75m
- ② Length between the first Branch Pipe and the farthest IDU: 30m
- ③ Length between IDU and the nearest branch pipe: 15m
- ④ Height difference between IDUs: 15m
- ⑤ Height difference between ODU and IDU: 30m

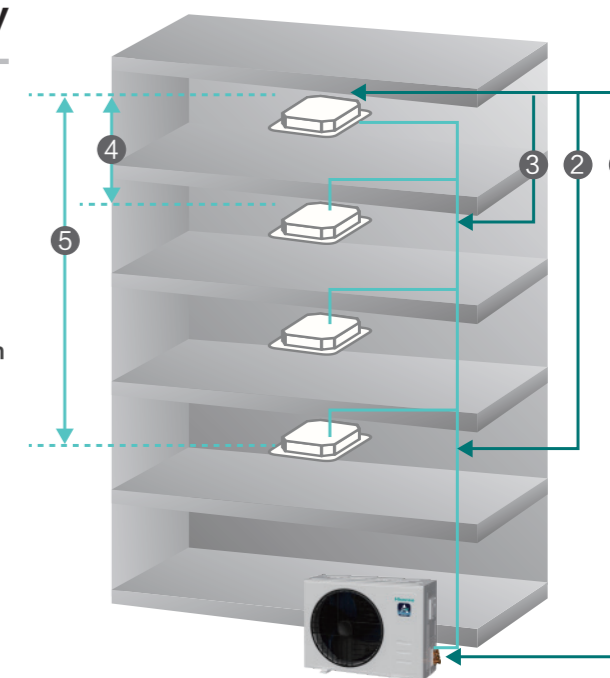

Multiple Piping Connection Types

Hi-Smart A series offers three piping connection options: flaring branch pipe, brazing branch pipe, and flaring branch headers, providing installers with multiple choices. The universal use of the head branches facilitates quick and convenient connection to pre-buried refrigerant pipelines, making it an excellent fit for real estate projects.

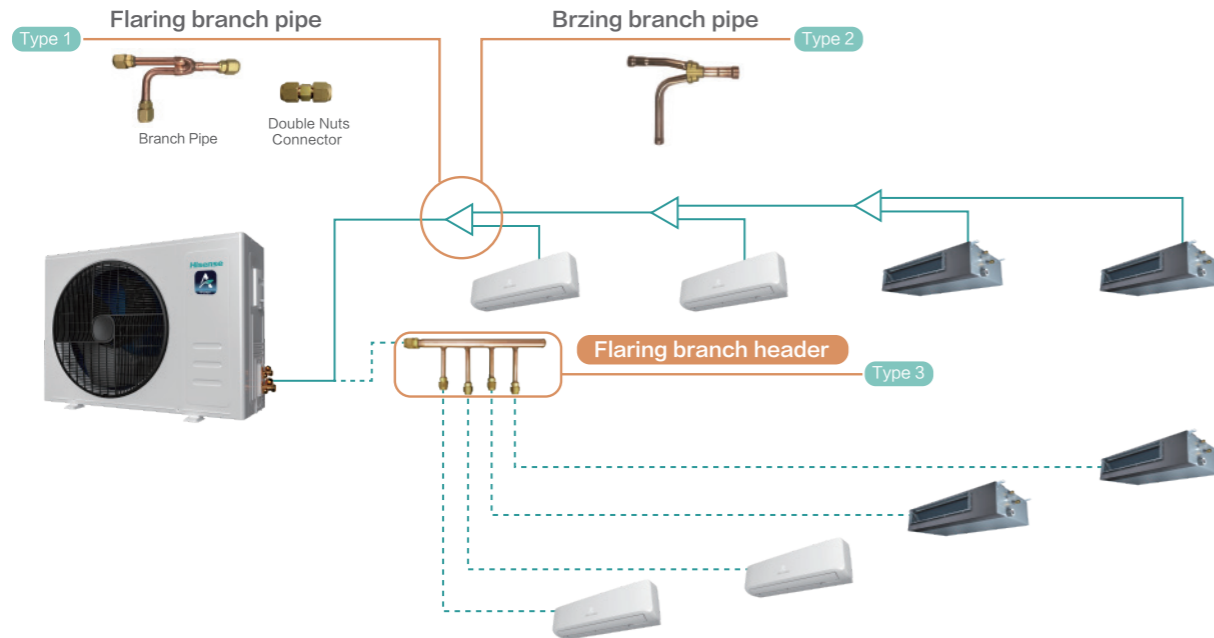

Brazing Free for Easier Installation

All flare connection based branch headers eliminate the need for on-site brazing, resulting in swift, safe, and quality installation.

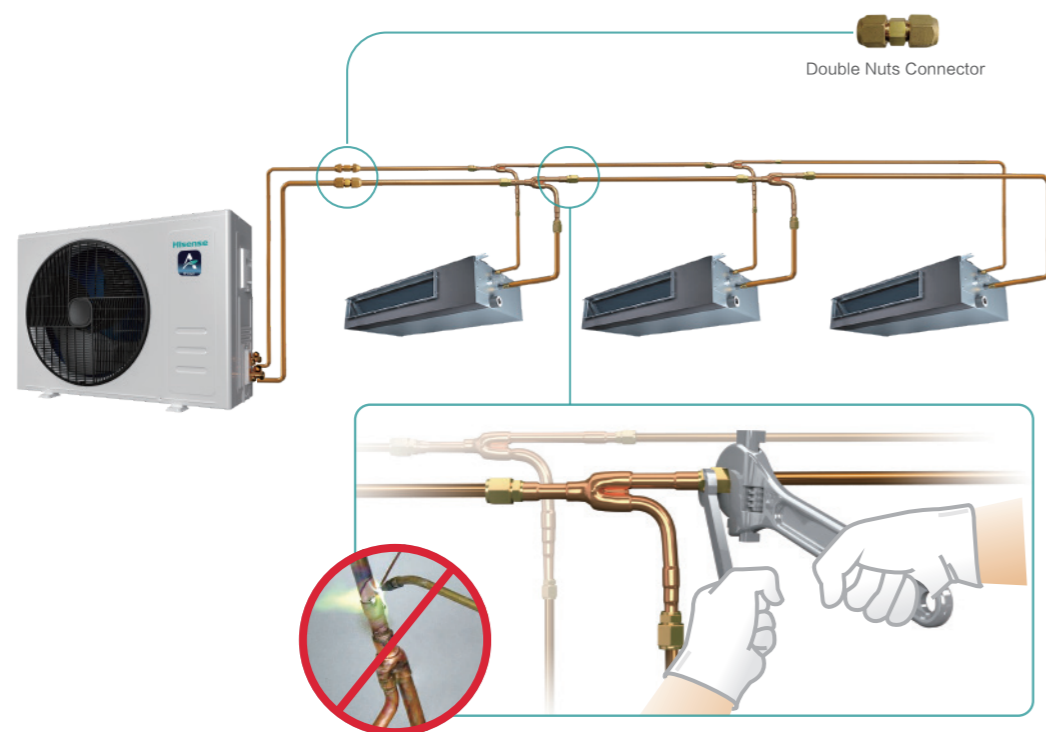

Hi-Smart A Series



		HP	3	3.5	4	5	6
		Model	AVW-27HJFAH1	AVW-34HJFAH1	AVW-42HJFAH1	AVW-48HJFAH1	AVW-54HJFAH1
Power Supply			1PH 220~240V 50Hz/60Hz				
Cooling	Capacity	kW	8.0	10.0	12.1	14.0	15.5
		kBtu/h	27.3	34.1	41.3	47.8	52.9
	Power Input	kW	2.22	2.96	3.32	4.24	4.84
	EER	kW/kW	3.60	3.38	3.65	3.30	3.20
Heating	SEER		6.41	6.91	8.11	7.91	7.80
	Capacity(Max./Nom.)	kW	9.5/8.0	11.2/10.0	14.0/12.1	16.0/14.0	17.0/15.5
		kBtu/h	32.4/27.3	38.2/34.1	47.8/41.3	54.6/47.8	58.0/52.9
	Power Input(Max./Nom.)	kW	2.30/1.70	2.99/2.35	3.74/2.85	4.23/3.26	4.60/3.69
COP(Max./Nom.)		kW/kW	4.14/4.70	3.74/4.25	3.74/4.25	3.78/4.30	3.70/4.20
	SCOP		4.40	4.30	4.70	4.70	4.65
Air Flow Rate		m ³ /min	45	45	75	75	75
Sound Pressure Level (Cooling/Heating)		dB(A)	52/54	53/55	54/55	54/55	54/56
Refrigerant	Type	-	R410A				
	Pre-charged Quantity	kg	1.8	1.8	2.0	3.0	3.0
Weight	Net Weight	kg	50	52	64	71	71
	Gross Weight	kg	54	55	77	83	83
Dimensions	External (H × W × D)	mm	670 × 900 × 320			770 × 980 × 360	
	Packing (H × W × D)	mm	717 × 1056 × 427			920 × 1100 × 505	
Ref. Piping	Gas	mm	φ 15.88	φ 15.88	φ 15.88	φ 15.88	φ 15.88
		inch	5/8	5/8	5/8	5/8	5/8
	Liquid	mm	φ 9.53	φ 9.53	φ 9.53	φ 9.53	φ 9.53
		inch	3/8	3/8	3/8	3/8	3/8
Connectable Indoor Units	Quantity	pcs	1-5	1-6	1-7	1-9	1-10
	Connection Ratio	-	50%-150%				
Piping Design	Max. total piping Length	m	40	40	60	70	70
	Max. piping Length	m	25	25	50	60	60
	Height Difference Between ODU and IDU	m	20	20	30	30	30
	Height Difference Between IDUs	m	10	10	15	15	15
Operation Range	Cooling	DB	-5~59 °C*				
	Heating	WB/DB	-21~17°C/-20~23°C				

Notes:
 1. Rated cooling capacity and rated heating capacity are tested in the following conditions:
 Cooling conditions: indoor air inlet temperature: 27°C DB 19°C WB, Outdoor air inlet temperature: 35°C DB, pipe length: 7.5m, pipe height difference: 0m Heating conditions: indoor air inlet temperature: 20°C DB, Outdoor air inlet temperature: 7°C DB 6°C WB, pipe length: 7.5m, pipe height difference: 0m
 2. *: When outdoor ambient temperature is 55~59°C, Cooling operates intermittently.

Hi-Smart A Series



HP		6.5	7	8	
Model		AVW-63HJFAH1	AVW-68HJFAH1	AVW-76HJFAH1	
Power Supply		1PH 220-240V 50Hz/60Hz			
Cooling	Capacity	kW	18.1	20.0	22.4
		kBtu/h	61.8	68.2	76.4
	Power Input	kW	5.76	6.67	8.00
	EER	kW/kW	3.14	3.00	2.80
	SEER		8.01	7.62	7.20
Heating	Capacity(Max./Nom.)	kW	20.0/18.1	22.4/20.0	25/22.4
		kBtu/h	68.2/61.8	74.6/68.2	85.3/76.4
	Power Input(Max./Nom.)	kW	5.29/4.21	6.21/4.88	7.28/5.74
	COP(Max./Nom.)	kW/kW	3.78/4.30	3.61/4.10	3.43/3.90
	SCOP		4.90	4.70	4.50
Air Flow Rate		m ³ /min	93	93	93
Sound Pressure Level (Cooling/Heating)		dB(A)	56/58	57/60	57/60
Refrigerant	Type		R410A		
	Pre-charged Quantity	kg	3.8	3.8	3.8
Weight	Net Weight	kg	97	97	97
	Gross Weight	kg	110	110	110
Dimensions	External (H×W×D)	mm	1080×980×360		
	Packing (H×W×D)	mm	1230×1100×505		
Ref. Piping	Gas	mm	φ19.05	φ19.05	φ19.05
		inch	3/4	3/4	3/4
	Liquid	mm	φ9.53	φ9.53	φ9.53
		inch	3/8	3/8	3/8
Connectable Indoor Units	Quantity	pcs	2-11	2-12	2-13
	Connection Ratio		50%-150%		
Piping Design	Max. total piping Length	m	120	120	120
	Max. piping Length	m	75	75	75
	Height Difference Between ODU and IDU	m	30	30	30
	Height Difference Between IDUs	m	15	15	15
Operation Range	Cooling	DB	-5-59 °C*		
	Heating	WB/DB	-21-17°C/-20-23°C		

Notes:
 1. Rated cooling capacity and rated heating capacity are tested in the following conditions:
 Cooling conditions: indoor air inlet temperature: 27°C DB 19°C WB, Outdoor air inlet temperature: 35°C DB, pipe length: 7.5m, pipe height difference: 0m Heating conditions: indoor air inlet temperature: 20°C DB, Outdoor air inlet temperature: 7°C DB 6°C WB, pipe length: 7.5m, pipe height difference: 0m
 2. ※When outdoor ambient temperature is 55-59°C, Cooling operates intermittently.

Hi-Smart L+ C+ Series

High Performance Beyond Expectations



New air flow grille

Air supply distance is increased by 24% together with the 30Pa ESP.

High-efficiency oil separator

Improve the capacity and ensure stable operation.

Heat exchanger with anti-corrosion fin

High anti-corrosion capability.

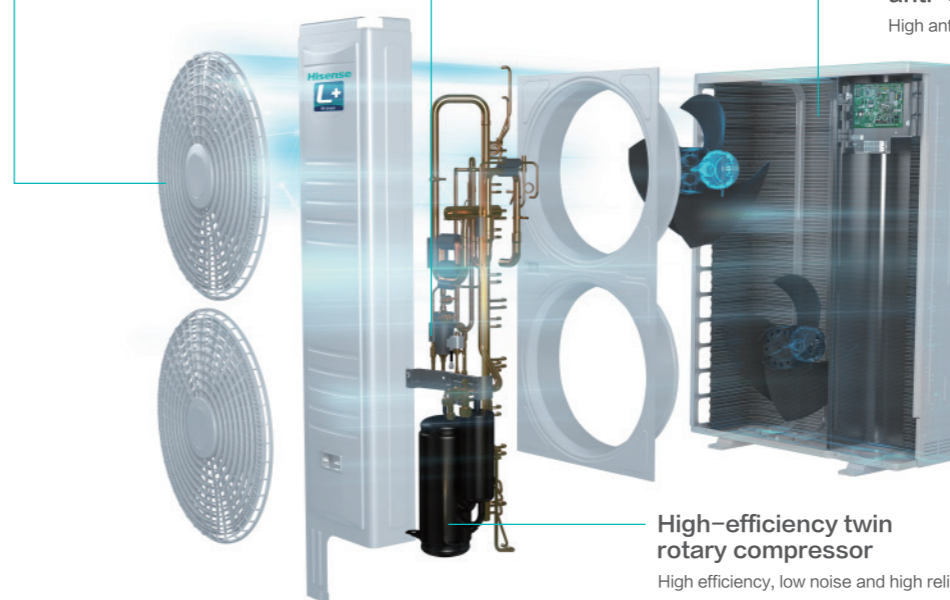

High-efficiency twin rotary compressor

High efficiency, low noise and high reliability.

Take Hi-Smart L+ Series as an example.

High-efficiency DC Inverter Compressor

A high-efficiency DC inverter dual rotary compressor is adopted. It features unique dual-pressure chamber design and symmetrical location, which can effectively reduce the vibration and noise and improve the compressor performance, especially the performance under low-frequency operation.

Moreover, the dual rotary compressor has a small lubricating oil injection volume with stable oil return, and comes with a gas-liquid separator, which makes the system more reliable.

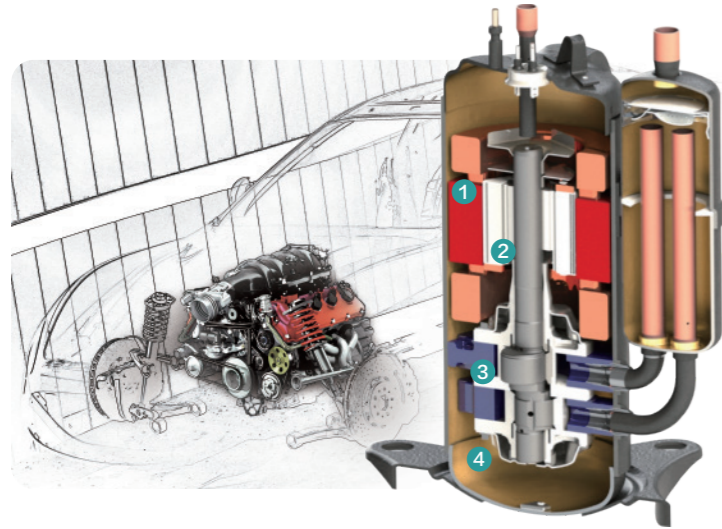

- 1 High-efficiency motor**
Optimize the motor design to improve compressor performance.
- 2 Optimized rotor design**
Lower the center of gravity of the compressor to reduce the noise and vibration.
- 3 Flat mechanism design**
Improve the volumetric efficiency and the total performance.
- 4 Screw interactive fastening**
Improve fastening effect and reduce deformation of the core.

Patented 360° Fitted Refrigerant Cooling Technology

To maintain the lifespan of the delicate electronic components, the unit uses patented 360° fitted refrigerant cooling technology to cool the whole electronic box effectively. It can overcome poor heat dissipation and solve high ambient temperature issues inside the electronic box, maintaining an efficient and reliable operation under harsh environment.



Note: 1. Compared with air-cooled technology, the temperature in electric box can be reduced about by 10%.

Wide Operating Range

Extended operation range creates wider application potential, in cooling mode the operation range is from -10°C* to 48°C and in heating mode the operation range is from -20°C to 26°C, which adapts to many extreme conditions.

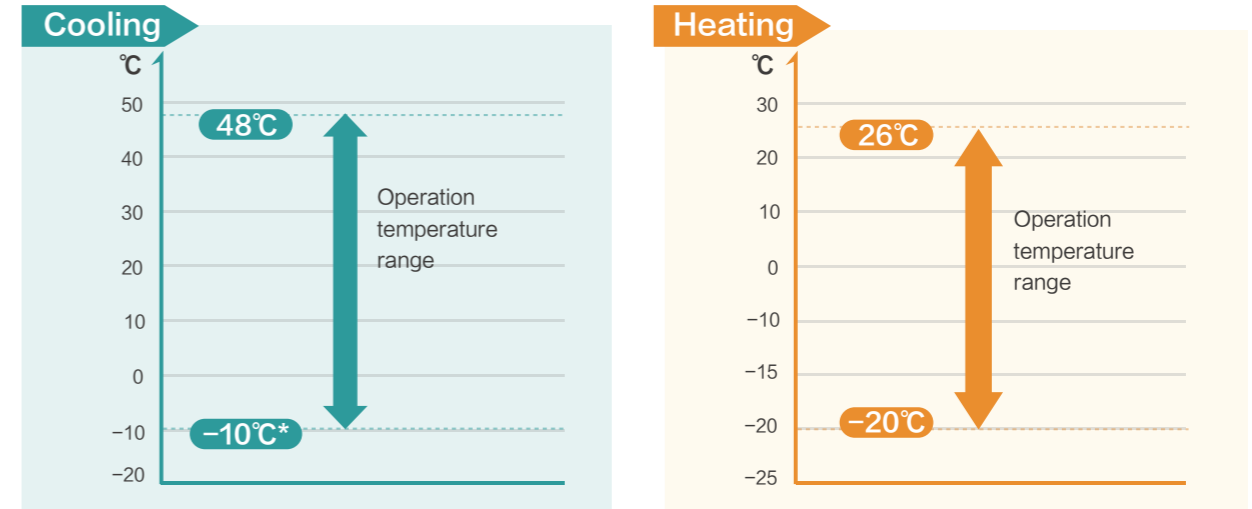

* In cooling mode, the operation is under interval operation when the temperature is below -5°C.

Dark Gray Fin (Standard)

All the heat exchangers adopt dark gray fin, which has excellent anti-corrosive performance. It is coated with epoxy resin using film-forming techniques while the traditional resins are acrylic resins. The epoxy resin is 1.5 times thicker than acrylic resin, and its acid-resistant, alkali-resistant and salt-fog resistant properties is 3 times better than acrylic resin.



Note: For the anti-corrosive solution for the whole outdoor unit, please contact with our local engineers.

Bistable Four-way Valve

The bistable four-way valve is adopted in the outdoor unit, which only consumes power when reversing. During the normal operation (regardless of cooling or heating), it is no need to be energized. Compared with conventional four-way valve, it is more energy-saving. Moreover, the reliability of valve coil is greatly improved.

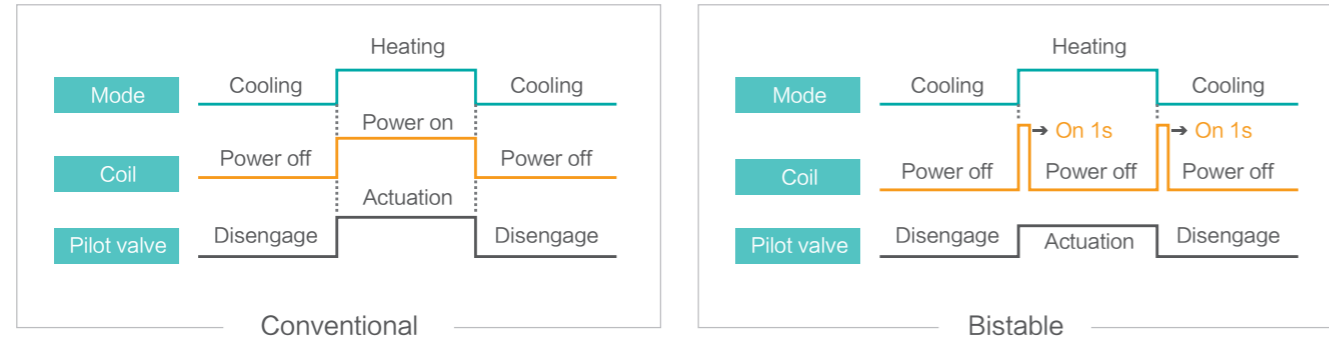
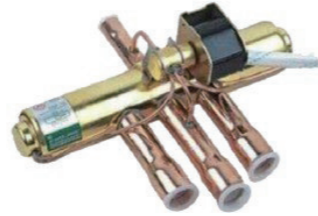

Further Air Discharge Distance

Optimized Air Duct System Design

An additional air duct like channel surrounding the fan is designed to further discharge the air and avoid discharge air from being absorbed again. Besides, together with the 30Pa external static pressure, air is tested to discharge up to 24% further compared with the conventional one.

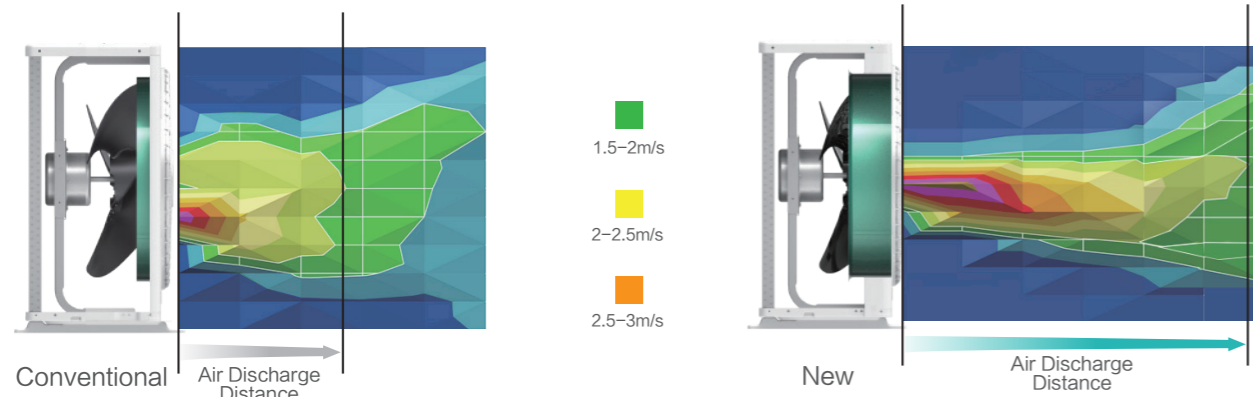
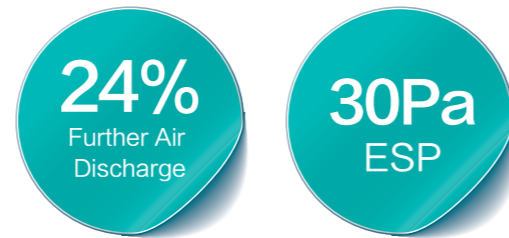

Hi-Smart L+ Series



Capacity (HP)		4.0	5.0	6.0	
Model		AVW-41HKFHH2	AVW-48HKFHH2	AVW-54HKFHH2	
Power Supply		AC 3Φ, 380-415V/50/60Hz			
Cooling	Capacity	12.1	14.0	15.5	
	Btu/h	41500	48000	53000	
	Power Input	2.79	3.43	4.18	
	EER	4.33	4.08	3.71	
	SEER	8.20	8.10	8.00	
Heating	Capacity	14.0	16.0	18.0	
	Btu/h	48000	54500	61500	
	Power Input	3.08	3.71	4.47	
	COP	4.55	4.31	4.03	
SCOP	4.85	4.70	4.55		
Ventilation	Air Flow Rate	120	120	127	
Sound Pressure Level	Cooling/Heating	52/55	52/55	53/56	
	dB(A)				
Weight	Net	112	113	114	
	Gross	123	124	125	
Outer Dimensions	Height	1380	1380	1380	
	Width	950	950	950	
	Depth	370	370	370	
	Height	1531	1531	1531	
Packing Dimensions	Width	1070	1070	1070	
	Depth	515	515	515	
	Height	515	515	515	
Cabinet Color			Grayish White		
Ref. Piping	Gas	mm	φ15.88	φ15.88	φ15.88
		in.	5/8	5/8	5/8
	Liquid	mm	φ9.53	φ9.53	φ9.53
	in.	3/8	3/8	3/8	
Refrigerant	Type		R410A		
	Before Shipment	kg	3.8	3.8	4.1
Connectable Indoor Units	Max. Qty.	pc	9	11	12
	Connection Ratio	%	50-150	50-150	50-150
Piping Design	Max. Piping Length	m	100	100	100
	Total Piping Length	m	150	150	150
	Height Difference Between ODU and IDU	m	50	50	50
	Height Difference Between IDUs	m	15	15	15
Operation Range	Cooling	DB(°C)	(-10*) -5 ~ 48		
	Heating	DB/WB(°C)	-20/-20.5 ~ 26/15.5		

NOTES:

- The rated cooling and heating capacity are tested in the following conditions:
Cooling Operation Conditions: indoor air inlet temperature: 27°C DB 19°C WB, outdoor air inlet temperature: 35°C DB, pipe length : 7.5m, pipe lift: 0m
Heating Operation Conditions: indoor air inlet temperature: 20°C DB, outdoor air inlet temperature: 7°C DB 6°C WB, pipe length: 7.5m, pipe lift: 0m
- The above noise values are measured in the anechoic chamber without reflected echo, therefore the impact of the reflected echo must be taken into consideration at the scene. Measurement point: 1m from the service cover surface and 1.5m from floor level.
- *1 When the temperature is between -10°C and -5°C, the cooling operation is under interval operation.
- The above performance data is obtained on the basis of the performance of this outdoor unit, with a 100%-combination of 4-way cassette type indoor units.

Hi-Smart C+ Series



Capacity (HP)		8.0	10.0	12.0	
Model		AVW-76HKFHH2	AVW-96HKFHH2	AVW-114HKFHH2	
Power Supply		AC 3Φ, 380-415V/50/60Hz			
Cooling	Capacity	kW	22.4	28.0	33.5
		Btu/h	76400	95500	114300
	Power Input	kW	6.22	8.12	13.40
	EER	W/W	3.60	3.45	2.50
	SEER	—	7.00	7.80	7.55
Heating	Capacity	kW	25.0	31.5	37.5
		Btu/h	85300	107500	128000
	Power Input	kW	5.81	7.59	10.08
	COP	W/W	4.30	4.15	3.72
	SCOP	—	4.50	4.50	4.30
Ventilation	Air Flow Rate	m³/min	150	163	163
Sound Pressure Level	Cooling/Heating	dB(A)	55/58	56/59	56/59
	Net	kg	145	157	158
Weight	Gross	kg	161	174	175
	Height	mm	1650	1650	1650
	Width	mm	1100	1100	1100
Outer Dimensions	Depth	mm	390	390	390
	Height	mm	1806	1806	1806
	Width	mm	1185	1185	1185
Packing Dimensions	Depth	mm	530	530	530
	Cabinet Color	—	Grayish White		
Ref. Piping	Gas	mm	φ22.2	φ25.4	φ25.4
		in.	7/8	1/1	1/1
	Liquid	mm	φ12.7	φ12.7	φ12.7
		in.	1/2	1/2	1/2
Refrigerant	Type	—	R410A		
	Before Shipment	kg	5.5	6.5	6.5
Connectable Indoor Units	Max. Qty.	pc	15	18	19
	Connection Ratio	%	50-150	50-150	50-150
Piping Design	Max. Piping Length	m	150	150	150
	Total Piping Length	m	300	300	300
	Height Difference Between ODU and IDU	m	50	50	50
		m	40	40	40
	Height Difference Between IDUs	m	15	15	15
Operation Range	Cooling	DB(°C)	(-10*) -5 - 48		
	Heating	DB/WB(°C)	-20/-20.5 - 26/15.5		

NOTES:

- The rated cooling and heating capacity are tested in the following conditions:
Cooling Operation Conditions: indoor air inlet temperature: 27°C DB 19°C WB, outdoor air inlet temperature: 35°C DB, pipe length : 7.5m, pipe lift: 0m
Heating Operation Conditions: indoor air inlet temperature: 20°C DB, outdoor air inlet temperature: 7°C DB 6°C WB, pipe length: 7.5m, pipe lift: 0m
- The above noise values are measured in the anechoic chamber without reflected echo, therefore the impact of the reflected echo must be taken into consideration at the scene.
Measurement point: 1m from the service cover surface and 1.5m from floor level.
- *1 When the temperature is between -10°C and -5°C, the cooling operation is under interval operation.
- The above performance data is obtained on the basis of the performance of this outdoor unit, with a 100%-combination of 4-way cassette type indoor units.

Hi-Smart **H** Series

Compact Size and Light Weight



H series outdoor units are compact in size for more convenient and flexible space design and installation. They hide in corners of balconies and yards or even on rooftops when necessary. With smaller and slimmer body frames, unnecessary weights are taken off, which makes installation or positioning simpler.

Aviation Level Design of Grilling

Hisense H series creates a high-quality quiet environment. The design of the grilling follows the design concept of the aircraft engine design, which conforms to the aerodynamics principle. The noise has been greatly reduced. The grilling also increases safety as being a preventative for child figure being injured by the fan blade.

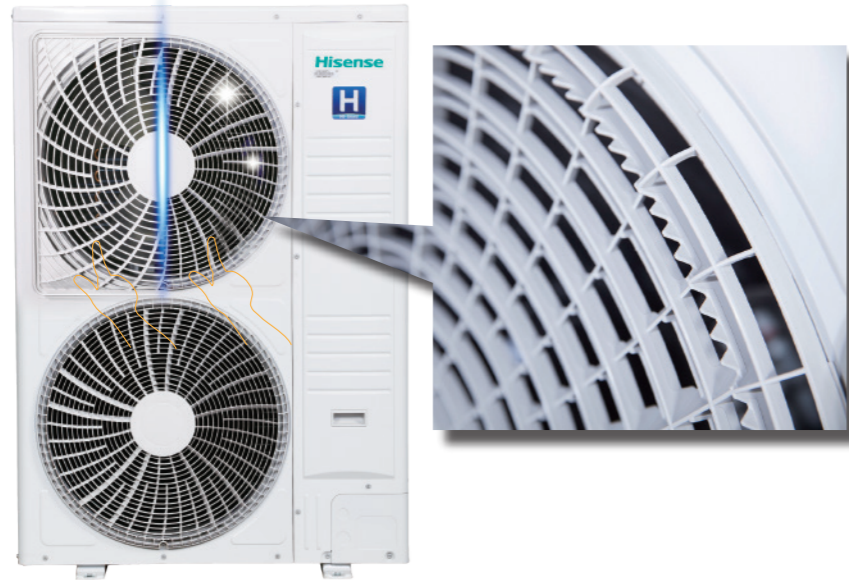

New Designed Air Channel

An additional air duct like channel surrounding the fan is designed to further discharge the air and avoid discharge air from being absorbed again. Air is tested to discharge up to 24% further compared with the conventional one. Besides, 30Pa external static pressure is available for units capacity ranged from 8HP to 12HP.

24%
Further Air Discharge

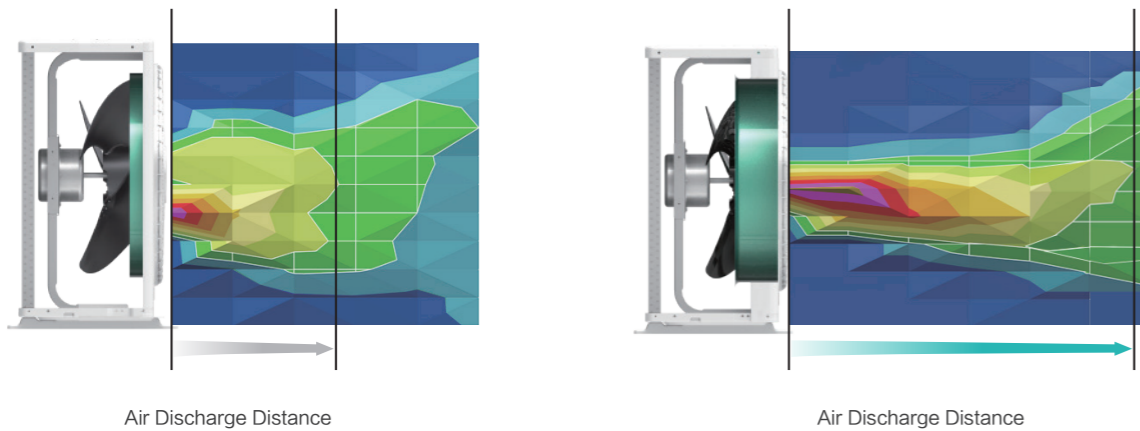

1.5-2m/s 2-2.5m/s 2.5-3m/s

Flexible Piping Connection

Installation restrictions on site does not stop Hisense mini VRF there with flexible piping directions which includes front, bottom, right, rear connections.



New Refrigerant Pipe Connection with Flare-nut Branch Pipe

Hisense VRF has newly developed the Flare-nut Branch Pipes, breaking through the common way of connecting refrigerant copper pipes by replacing welding processes with simple and safe flare nuts connections.

- Convenient and simple installation
- Saving installation time and cost
- Enhanced safety with no fire-involving process
- Preventing leakages due to poor welding
- No hot work permit application is required

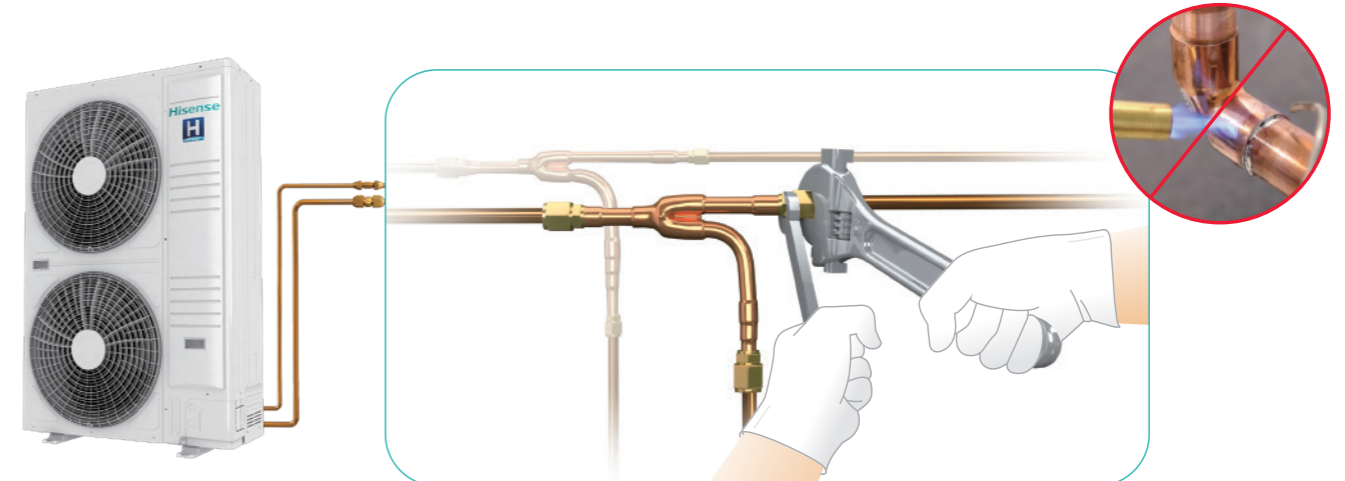
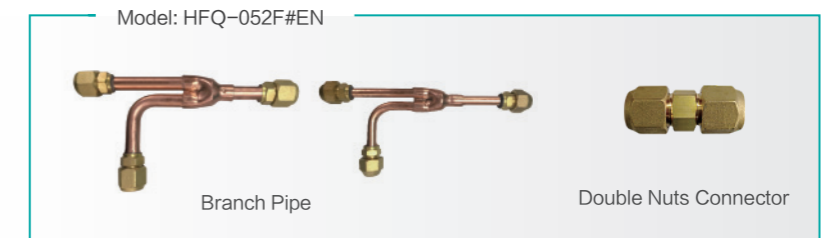

Excellent Piping Length

Increased piping length allows for flexible design and installation. Hisense inverter technology and two-level cooling technology allows longer piping length and outstanding height differences. The air-conditioning system can be implemented more flexibly.

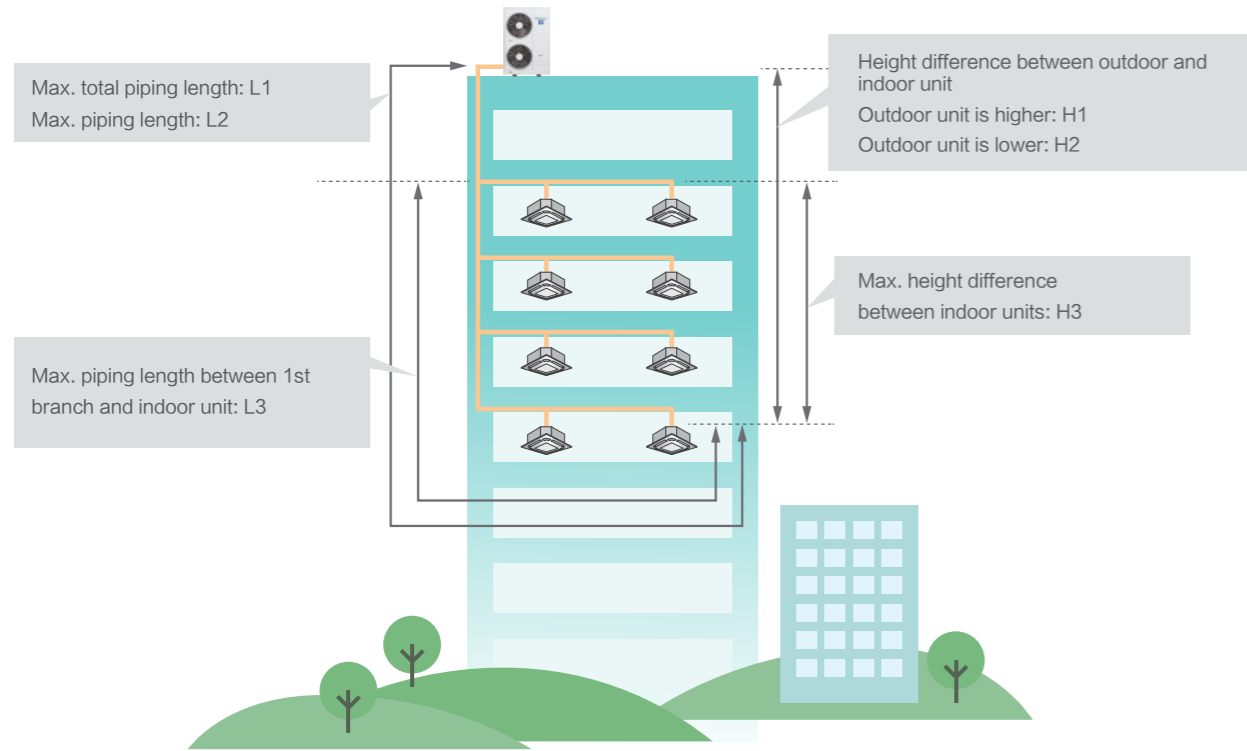

Power supply	AC 1 φ, 220-240V/ 50/60Hz	AC 3 φ, 380-415V/ 50/60Hz	AC 3 φ, 380-415V/ 50/60Hz
HP	4/5/6HP	8HP	10/12HP
Picture			
Max. total piping length L1	120	150	250
Max. piping length L2	75	100	100
Max. length between the first branch pipe and the farthest indoor unit L3	30	30	40
Height difference between ODU and IDU	Outdoor unit is higher H1	30	50
	Outdoor unit is lower H2	30	40
Height difference between IDUs H3	10	15	15

Hi-Smart H Series



		4HP	5HP	6HP	8HP	10HP	12HP
Model		AVW-43HJFHE2	AVW-48HJFHE2	AVW-54HJFHE2	AVW-76HKFHE2	AVW-96HKFHE2	AVW-114HKFHE2
Power Supply		AC1 φ, 220-240V/50/60Hz			AC3 φ, 380-415V/50/60Hz		
Cooling	Capacity	kW	12.5	14.0	15.5	22.4	28.0
		kBtu/h	42.7	47.8	52.9	76.5	95.6
	Power Input	kW	3.03	4.05	4.68	6.93	8.97
	EER	kW/kW	4.12	3.46	3.31	3.23	3.12
Heating	SEER	kW/kW	8.02	7.67	7.63	6.36	7.33
	Capacity	kW	14.0	16.0	18.0	25.0	31.5
		kBtu/h	47.8	54.6	61.4	85.3	107.5
	Power Input	kW	3.14	3.71	4.47	7.35	7.91
Ventilation	COP	kW/kW	4.46	4.31	4.03	3.4	3.98
	SCOP	kW/kW	4.75	4.48	4.31	4.04	4.27
	Air Flow Rate	m ³ /min	90	90	100	127	150
Sound	Fan Quantity		2	2	2	2	2
	Sound Pressure Level	dB(A)	50/52	52/54	53/55	57/58	58/59
Compressor	Type		Rotary				
	Quantity		1	1	1	1	1
Refrigerant	Type		R410A				
	Pre-charge Quantity		3.8	3.8	4.1	5.63	5.5
Weight	Net Weight	kg	93	95	97	124	145
	Gross Weight	kg	112	112	112	139	161
Dimensions	External	H mm	1380	1380	1380	1380	1650
		W mm	950	950	950	950	1100
		D mm	370	370	370	370	390
	Packing	H mm	1531	1531	1531	1531	1806
		W mm	1070	1070	1070	1070	1185
		D mm	515	515	515	515	530
Cabinet Color			Ivory White			Grayish White	
	Ref. Piping	Gas	mm	φ9.53	φ9.53	φ9.53	φ9.53
		Liquid	mm	φ15.88	φ15.88	φ15.88	φ19.05
Piping Design	Max. Piping Length	m	75	75	75	100	
	Height Difference Between ODU and IDU	m	30	30	30	40	
		m	30	30	30	40	
Operation Range	Height Difference Between IDUs	m	10	10	10	15	
	Cooling	°C DB	-5~46			-5~50	
	Heating	°C WB	-20~15.5			-20~15.5	

Notes:

- Rated cooling capacity and rated heating capacity are tested in the following conditions:
Cooling conditions: indoor air inlet temperature: 27°C DB 19°C WB, Outdoor air inlet temperature: 35°C DB, pipe length: 7.5m, pipe height difference: 0m
Heating conditions: indoor air inlet temperature: 20°C DB, Outdoor air inlet temperature: 7°C DB 6°C WB, pipe length: 7.5m, pipe height difference: 0m
- The above noise values are measured in the anechoic chamber without reflected echo, therefore the impact of the reflected echo must be included at the scene.
- The final appearance of outdoor units is subject to the actual products.
- The above performance data is obtained on the basis of the performance of this outdoor unit, with a 100%-combination of 4-way cassette type indoor units.

INDOOR UNITS

4-Way Cassette / Mini 4-Way Cassette

1-Way Cassette

2-Way Cassette

Console

Ceiling Ducted (AC/DC Low-height)

Ceiling Ducted(High/Low Static Pressure)

Wall Mounted

Floor Standing

Ceiling & Floor

Floor Concealed

All Fresh Air Indoor Unit

Heat Recovery Ventilator

AHU Connection KIT

AIR
CONDITIONING
SOLUTION

Indoor Units Line-up

HP		0.6	0.8	1.0	1.3	1.5	1.6	1.8	1.9	2.0	2.3	2.5	3.0	3.3	4.0	4.5	5.0	6.0	8.0	10.0
kBtu/h		5	7	9	12	14	15	17	18	19	22	24	27	30	38	42	48	54	76	96
R32 R410A				•	•		•			•	•	•	•	•	•		•	•		
R32 R410A		•	•	•	•		•	•		•										
		•	•	•	•		•			•		•								
			•	•	•	•			•			•	•	•	•		•	•		
		•	•	•	•		•	•												
		•	•	•	•		•	•		•	•	•								
R32 R410A		•	•	•	•		•			•		•								
R32 R410A			•	•	•		•			•		•	•	•	•	•	•	•	•	•
			•	•	•		•			•	•	•	•	•	•		•	•		
			•	•	•		•			•	•	•	•	•	•		•	•		
R32 R410A		•	•	•	•		•			•		•	•							
															•		•	•		•
										•	•	•	•	•	•		•			
				•	•				•		•	•	•	•	•		•			

Note: 1. For more details, check each unit's respective pages. 2. * Be compatible with both R32 and R410a.

RELIABILITY

EFFICIENCY

COMFORT

FLEXIBILITY

OUTDOOR UNIT

INDOOR UNIT

CONTROL SYSTEM

ACCESSORY

Indoor Units Feature Overview

Unit	Accessories									
	Drain Pump (built-in)	Drain Pump (external)	3D Airflow Panel	Filter	Humidity Sensor	AirPure Kit	Motion Sensor	Hi-Motion	Outlet Air Temp Sensor	Float Switch
4-Way Cassette	●	○	×	●	○	○	○	○	●	●
Mini 4-Way Cassette	●	○	×	●	○	○	○	○	●	●
1-Way Cassette	●	×	×	●	○	○	×	○	×	●
2-Way Cassette	●	○	×	●	×	×	×	○	●	●
Console	×	○	×	●	○	×	×	○	×	×
Ceiling Ducted (AC Low-height)	●	○	○	●	○	○	×	○	×	●
Ceiling Ducted (DC Low-height)	●	○	○	●	○	○	×	○	●	●
Ceiling Ducted (DC High Static Pressure) AVD-07-AVD-54	○	○	×	●	○	○	×	○	●	●
Ceiling Ducted (DC High Static Pressure) AVD-76 & AVD-96	○	○	×	○	○	○	×	○	●	●
Ceiling Ducted (High Static Pressure)	○	○	×	●	○	○	×	○	×	●
Ceiling Ducted (Low Static Pressure)	○	○	×	●	○	○	×	○	×	●
Wall Mounted	×	×	×	●	○	○	×	○	●	×
Floor Standing	×	×	×	●	○	×	×	×	×	×
Ceiling & Floor	×	○	×	●	×	×	×	○	●	×
Floor Concealed	×	○	×	×	×	×	×	○	●	×

Remarks: Standard: ● Optional: ○ Incompatible: ×

Unit	Features											
	Dry Contact Input	Windows Linkage	Dry Contact Output	Fresh Air Intake	Sleep	Quiet	ECO	Individual Louver Control	Breeze Mode	Self Cleaning	Auto Fan Speed	Dynamic ESP
4-Way Cassette	●	●	●	●	●	●	●	●	●	●	●	×
Mini 4-Way Cassette	●	●	●	●	●	●	●	●	●	●	●	×
1-Way Cassette	●	●	●	●	●	●	●	●	×	●	●	×
2-Way Cassette	●	×	●	●	×	×	×	●	×	×	●	×
Console	●	×	●	●	●	●	●	×	×	×	×	×
Ceiling Ducted (AC Low-height)	●	●	●	●	●	●	●	×	×	×	×	×
Ceiling Ducted (DC Low-height)	●	●	●	●	●	●	●	×	×	●	●	×
Ceiling Ducted (DC High Static Pressure) AVD-07-AVD-54	●	●	●	●	●	●	●	×	×	●	●	●
Ceiling Ducted (DC High Static Pressure) AVD-76 & AVD-96	●	●	●	×	●	●	●	×	×	●	●	●
Ceiling Ducted (High Static Pressure)	●	●	●	●	×	×	●	×	×	×	×	×
Ceiling Ducted (Low Static Pressure)	●	●	●	●	×	×	●	×	×	×	×	×
Wall Mounted	●	●	●	×	●	●	●	×	×	●	●	×
Floor Standing	●	●	●	×	●	×	●	×	×	●	●	×
Ceiling & Floor	●	×	●	×	×	×	×	×	×	×	×	×
Floor Concealed	●	×	●	×	●	●	●	×	×	×	●	×

Remarks: Standard: ● Optional: ○ Incompatible: ×

RELIABILITY

EFFICIENCY

COMFORT

FLEXIBILITY

OUTDOOR UNIT

INDOOR UNIT

CONTROL SYSTEM

ACCESSORY

4-Way Cassette Mini 4-Way Cassette

Compact and Classy Design

The 4-way cassette is as slim as 238mm, and the mini 4-way cassette is only 215mm, making them suitable for narrow ceiling spaces. The newly designed panel seamlessly integrates with indoor aesthetics.

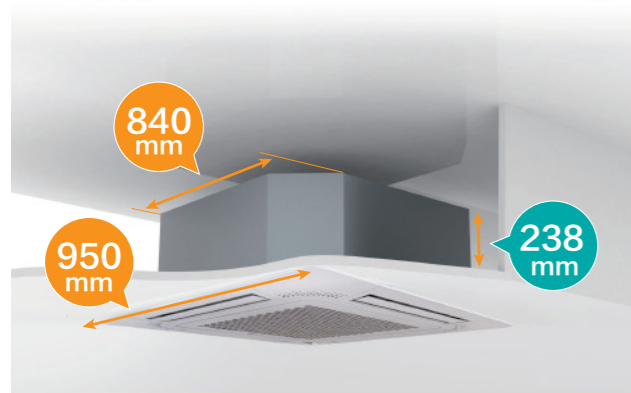

4-way Cassette

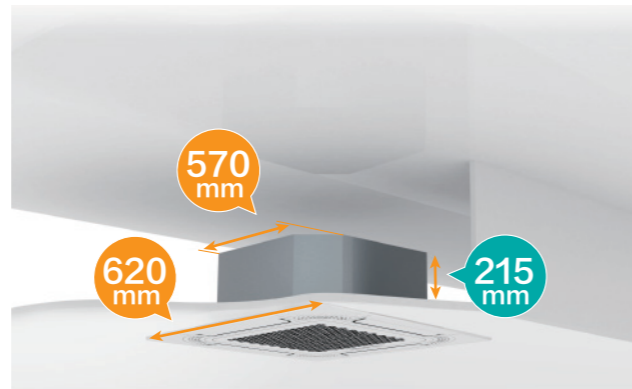

Mini 4-way Cassette

Higher Installation

The cassette unit is capable of blowing air from ceiling heights of up to 4.2m, ensuring effective air distribution even in rooms with high ceilings.

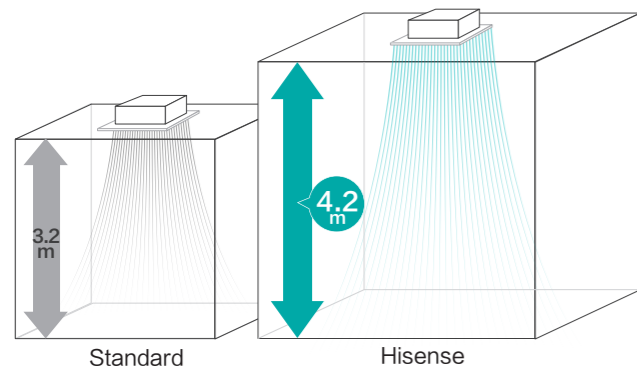

Breeze Mode

Under the new designed breeze mode, the cold air is blown out from the microholes in the panel, and the unit is working in a mute mode, which can avoid blowing air directly on people and achieve more even and comfortable airflow.

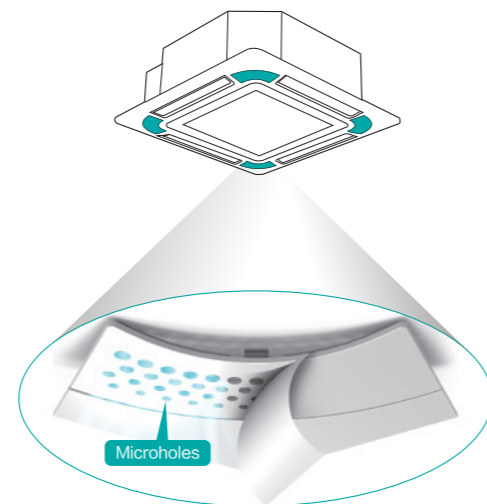

Individual Louvers Control

4-way cassette louvers are now capable of individual control to freely choose how you want your AC unit supplies air according to different needs, applications and installation layouts. Each louver has 7 adjustable angle settings with a maximum angle of up to 64°.

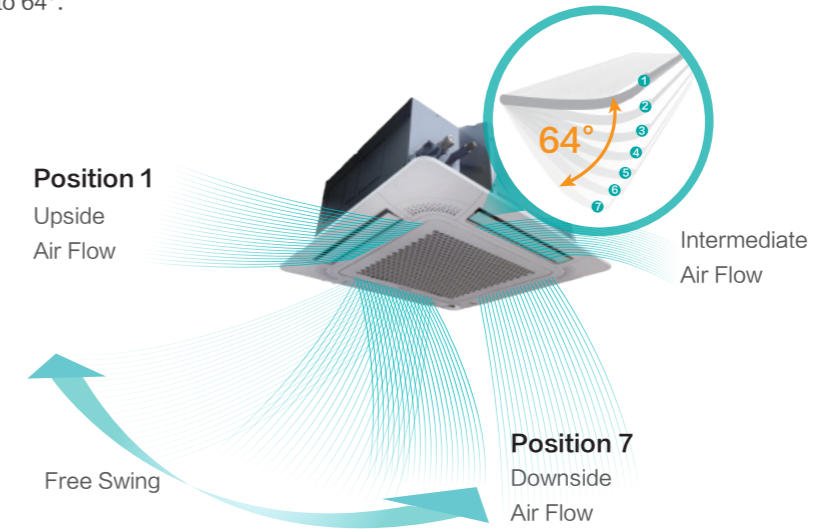

Self-cleaning Function

The cassette unit is featured with self-cleaning function. With just a press on the controller, the unit cleans itself automatically without manual intervention. It not only ensures clean and healthy air supply but also saves your valuable time and cost.



Motion Sensor

The sensor detects human presence to automatically switch the cassette unit on or off and adjust the airflow direction towards people or away from them. When the area becomes crowded, the system automatically lowers the set temperature to maintain comfort, and vice versa.

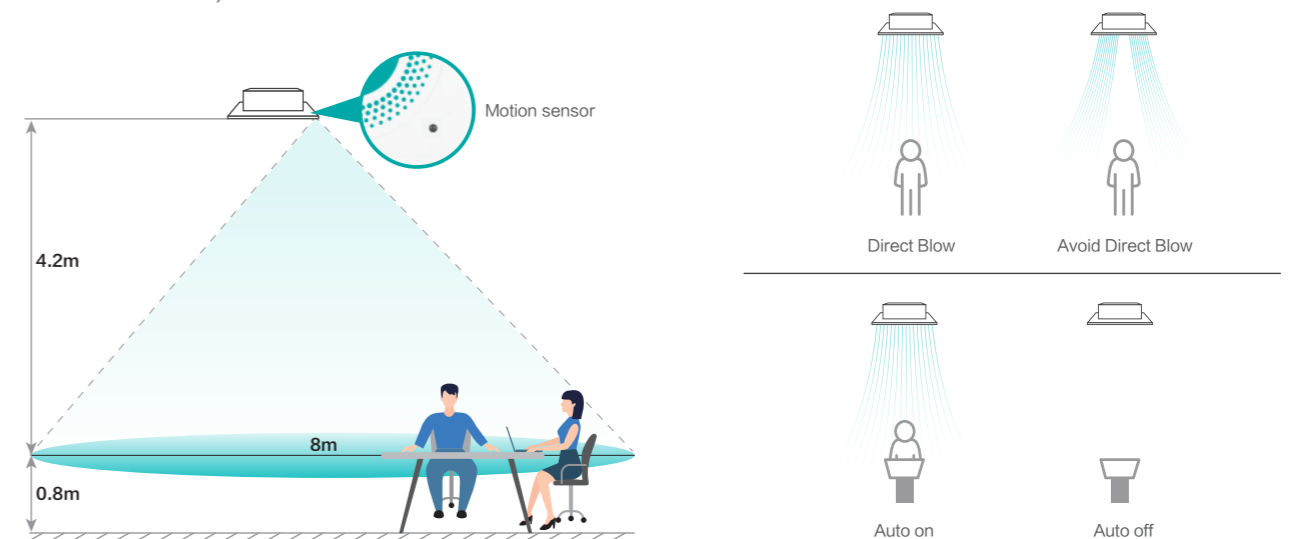

R32 | R410A

4-Way Cassette



Model	AVBC-09 HJDBA	AVBC-12 HJDBA	AVBC-15 HJDBA	AVBC-19 HJDBA	AVBC-22 HJDBA	AVBC-24 HJDBA	AVBC-27 HJDBA	AVBC-30 HJDBA	AVBC-38 HJDBA	AVBC-48 HJDBA	AVBC-54 HJDBA			
Power supply	AC 1 φ, 220V~240V/50Hz/60Hz													
Capacity	Cooling	kW	2.8	3.6	4.5	5.6	6.3	7.1	8.0	9.0	11.2	14.0	16.0	
		Btu/h	9,600	12,300	15,300	19,100	21,500	24,200	27,300	30,700	38,200	47,800	54,600	
Capacity	Heating	kW	3.2	4.0	5.0	6.3	7.1	8.0	9.0	10.0	12.5	16.0	18.0	
		Btu/h	10,900	13,700	17,100	21,500	24,200	27,300	30,700	34,100	42,700	54,600	61,400	
Power Input	Cooling	W	20	30	40	50	50	60	70	70	80	130	130	
		W	20	30	40	50	50	60	70	70	80	130	130	
Sound Pressure	Cooling	dB(A)	30/28/28/27/26/26	32/29/29/28/27/26	33/31/29/29/27/26	34/31/30/28/28/26	36/33/32/31/29/28	36/33/32/31/29/28	37/36/35/33/31/30	37/36/35/33/31/30	42/40/38/36/34/33	46/44/40/38/36/34	46/44/41/40/38/36	
		dB(A)	30/28/28/27/26/26	32/29/29/28/27/26	33/31/29/29/27/26	34/31/30/28/28/26	36/33/32/31/29/28	36/33/32/31/29/28	37/36/35/33/31/30	37/36/35/33/31/30	42/40/38/36/34/33	46/44/40/38/36/34	46/44/41/40/38/36	
Air Flow Rate	Cooling	m³/min	15.0/12.8/12.0/10.8/10.0/8.8	17.0/14.0/12.8/11.8/10.8/9.1	19.0/15.0/13.9/12.6/11.4/10.5	19.0/15.0/13.9/12.6/11.8/10.5	26.0/20.0/18.3/17.0/15.1/13.0	27.0/21.1/19.1/18.0/16.1/14.7	25.0/22.3/19.6/17.9/16.9/15.3	31.0/29.5/28.7/26.0/23.5/20.5	37.0/33.5/30.7/28.9/24.2/22.4	37.0/34.0/30.7/28.9/24.2/22.4		
		m³/min	15.0/12.8/12.0/10.8/10.0/8.8	17.0/14.0/12.8/11.8/10.8/9.1	19.0/15.0/13.9/12.6/11.4/10.5	19.0/15.0/13.9/12.6/11.8/10.5	26.0/20.0/18.3/17.0/15.1/13.0	27.0/21.1/19.1/18.0/16.1/14.7	25.0/22.3/19.6/17.9/16.9/15.3	31.0/29.5/28.7/26.0/23.5/20.5	37.0/33.5/30.7/28.9/24.2/22.4	37.0/34.0/30.7/28.9/24.2/22.4		
Piping	Connection Type	-	Flare-nut Connection(with Flare Nuts)											
		Liquid	mm	φ6.35	φ6.35	φ6.35	φ6.35	φ6.35	φ9.53	φ9.53	φ9.53	φ9.53	φ9.53	φ9.53
			inch	(1/4)	(1/4)	(1/4)	(1/4)	(1/4)	(3/8)	(3/8)	(3/8)	(3/8)	(3/8)	(3/8)
		Gas	mm	φ12.7	φ12.7	φ12.7	φ12.7	φ12.7	φ15.88	φ15.88	φ15.88	φ15.88	φ15.88	φ15.88
			inch	(1/2)	(1/2)	(1/2)	(1/2)	(1/2)	(5/8)	(5/8)	(5/8)	(5/8)	(5/8)	(5/8)
Condensate Drain	-	O.D. 32												
Weight	Net Weight	kg	20	20	20	20	21	21	23	23	26	26	26	
		kg	24	24	24	24	25	25	27	27	31	31	31	
Dimensions	External	H mm	238	238	238	238	238	238	238	238	288	288	288	
		W mm	840	840	840	840	840	840	840	840	840	840	840	
		D mm	840	840	840	840	840	840	840	840	840	840	840	
	Packaging	H mm	292	292	292	292	292	292	292	292	342	342	342	
		W mm	945	945	945	945	945	945	945	945	945	945	945	
		D mm	945	945	945	945	945	945	945	945	945	945	945	
Decoration Panel	Model	-	HPE-GNK1											
		-	Neutral White											
	Body	H mm	47	47	47	47	47	47	47	47	47	47	47	
		Dimensions	W mm	950	950	950	950	950	950	950	950	950	950	950
			D mm	950	950	950	950	950	950	950	950	950	950	950
	Packaging	H mm	100	100	100	100	100	100	100	100	100	100	100	
		Dimensions	W mm	1022	1022	1022	1022	1022	1022	1022	1022	1022	1022	1022
			D mm	1022	1022	1022	1022	1022	1022	1022	1022	1022	1022	1022
	Net Weight	kg	5.7	5.7	5.7	5.7	5.7	5.7	5.7	5.7	5.7	5.7	5.7	
	Gross Weight	kg	8.0	8.0	8.0	8.0	8.0	8.0	8.0	8.0	8.0	8.0	8.0	

Notes:

- The nominal cooling capacity and heating capacity are based on following conditions:
Cooling Operation Conditions
Indoor Air Inlet Temperature: 27°C DB (80°F DB), 19.0°C WB (66.2°F WB)
Outdoor Air Inlet Temperature: 35°C DB (95°F DB)
Piping Length: 7.5 Meters Piping Lift: 0 Meter
Heating Operation Conditions
Indoor Air Inlet Temperature: 20°C DB (68°F DB)
Outdoor Air Inlet Temperature: 7°C DB (45°F DB), 6°C WB (43°F WB)
- The sound pressure level is based on following conditions: 1.5m beneath the unit.
The above data was measured in an anechoic chamber so that reflected sound should be taken into consideration in the field.

R32 | R410A

Mini 4-Way Cassette

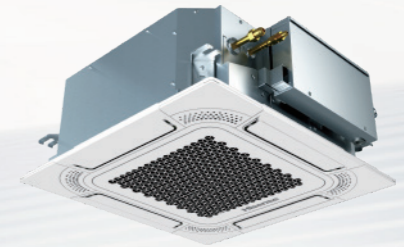

Model	AVC-05HJDBA	AVC-07HJDBA	AVC-09HJDBA	AVC-12HJDBA	AVC-15HJDBA	AVC-17HJDBA	AVC-19HJDBA			
Power supply	AC 1 φ, 220V~240V/50Hz/60Hz									
Capacity	Cooling	kW	1.5	2.2	2.8	3.6	4.5	5.0	5.6	
		Btu/h	5,100	7,500	9,600	12,300	15,300	17,000	19,100	
Capacity	Heating	kW	2.0	2.5	3.3	4.2	5.0	5.6	6.3	
		Btu/h	6,800	8,500	11,200	14,300	17,000	19,100	21,500	
Power Input	Cooling	W	14	14	14	16	22	30	40	
		W	14	14	14	16	22	30	40	
Sound Pressure	Cooling	dB(A)	30/29/28/26	30/29/28/26	32/30/28/26	34/32/29/26	38/36/31/28	42/39/36/31	45/42/38/34	
		dB(A)	30/29/28/26	30/29/28/26	32/30/28/26	34/32/29/26	38/36/31/28	42/39/36/31	45/42/38/34	
Air Flow Rate	m³/min	7.2/6.5/6.2/5.6	7.2/6.5/6.2/5.6	7.8/7.2/6.5/5.8	7.8/7.2/6.5/5.8	9.3/8.7/7.1/6.7	11.0/9.5/8.7/7.1	12.5/10.8/9.3/8.0		
Piping	Connection Type	-	Flare-nut Connection(with Flare Nuts)							
		Liquid	mm	φ6.35	φ6.35	φ6.35	φ6.35	φ6.35	φ6.35	φ6.35
			inch	(1/4)	(1/4)	(1/4)	(1/4)	(1/4)	(1/4)	(1/4)
		Gas	mm	φ12.7	φ12.7	φ12.7	φ12.7	φ12.7	φ12.7	φ12.7
			inch	(1/2)	(1/2)	(1/2)	(1/2)	(1/2)	(1/2)	(1/2)
Condensate Drain	-	O.D. 32								
Weight	Net Weight	kg	14.5	14.5	14.8	14.8	15.8	15.8	15.8	
		kg	17.3	17.3	17.6	17.6	18.6	18.6	18.6	
Dimensions	External	H mm	215	215	215	215	215	215	215	
		W mm	570	570	570	570	570	570	570	
		D mm	570	570	570	570	570	570	570	
	Packaging	H mm	292	292	292	292	292	292	292	
		W mm	730	730	730	730	730	730	730	
		D mm	668	668	668	668	668	668	668	
Decoration Panel	Model	-	HPE-DNK1							
		-	Neutral White							
	Body	H mm	37	37	37	37	37	37	37	
		Dimensions	W mm	620	620	620	620	620	620	620
			D mm	620	620	620	620	620	620	620
	Packaging	H mm	115	115	115	115	115	115	115	
		Dimensions	W mm	690	690	690	690	690	690	690
			D mm	680	680	680	680	680	680	680
	Net Weight	kg	2.7	2.7	2.7	2.7	2.7	2.7	2.7	
	Gross Weight	kg	4.0	4.0	4.0	4.0	4.0	4.0	4.0	

Notes:

- The nominal cooling capacity and heating capacity are based on following conditions:
Cooling Operation Conditions
Indoor Air Inlet Temperature: 27°C DB (80°F DB), 19.0°C WB (66.2°F WB)
Outdoor Air Inlet Temperature: 35°C DB (95°F DB)
Piping Length: 7.5 Meters Piping Lift: 0 Meter
Heating Operation Conditions
Indoor Air Inlet Temperature: 20°C DB (68°F DB)
Outdoor Air Inlet Temperature: 7°C DB (45°F DB), 6°C WB (43°F WB)
- The sound pressure level is based on following conditions: 1.5m beneath the unit.
The above data was measured in an anechoic chamber so that reflected sound should be taken into consideration in the field.

RELIABILITY
EFFICIENCY
COMFORT
FLEXIBILITY
OUTDOOR UNIT
INDOOR UNIT
CONTROL SYSTEM
ACCESSORY

1-Way Cassette

Ultra-Thin Space-Saving Design

Less Space, More Grace. Effortlessly fit into tight ceiling spaces without compromising on performance.



Self-Cleaning Tech

Self-cleaning and 56°C sterilization keep the unit clean and your air healthy, with no manual cleaning needed. Breathe easy, live healthy.



3DAirflow, All-Round Comfort

With 7 adjustable angles, the independently controlled louvers deliver 3D airflow further and downward that reaches every corner.

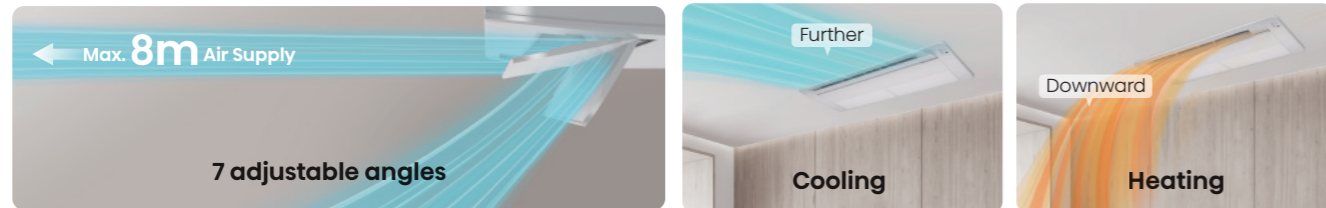

No Ductwork, Easier Installation and Maintenance

No ducts, no hassle. Ductwork is not required, making installation faster, easier, and more budget-friendly than ever. Access the PCB by simply removing the panel and filter. No extra service port needed, no damage to the wall, just simplified maintenance.

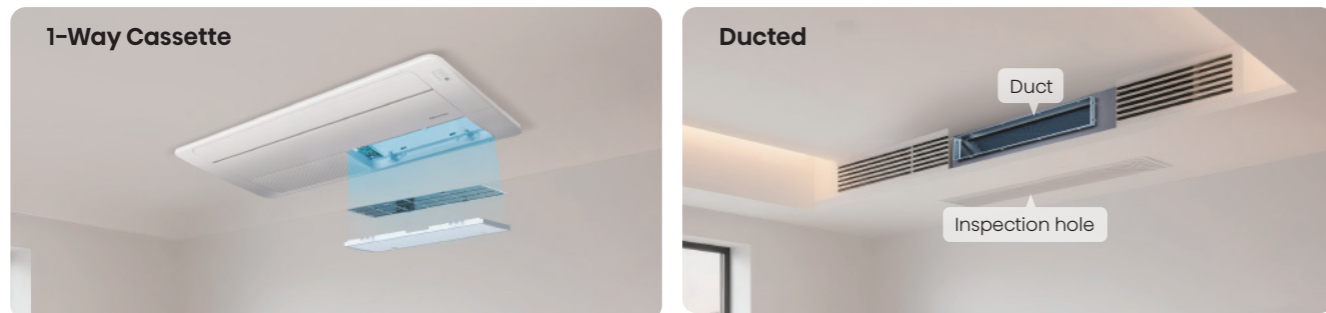

1-Way Cassette



Model		AVY-05HJDA	AVY-07HJDA	AVY-09HJDA	AVY-12HJDA	AVY-15HJDA	AVY-19HJDA	AVY-24HJDA	
Power Supply		AC 1ϕ 220V~240V 50/60Hz							
Capacity	Cooling	kW	1.8	2.2	2.8	3.6	4.5	5.6	7.0
		Btu/h	6,100	7,500	9,600	12,300	15,400	19,100	24,000
	Heating	kW	2.1	2.5	3.2	4.0	5.0	6.3	8.0
		Btu/h	7,100	8,500	10,900	13,600	17,100	21,500	27,300
Power Input	W	18	18	18	25	38	40	74	
Sound Pressure	dB(A)	32/31/29/ 28/26/24	32/31/29/ 28/26/24	33/31/29/ 28/26/24	38/36/34/ 33/30/26	42/40/35/ 33/31/27	41/39/36/ 34/32/28	48/44/41/ 37/34/29	
Airflow Rate	m ³ /min	7.1/6.8/6.4/ 5.9/5.5/5.3	7.1/6.8/6.4/ 5.9/5.5/5.3	7.5/7.1/6.4/ 5.9/5.5/5.3	9.1/8.4/7.8/ 7.1/6.4/5.9	11.0/9.5/7.8/ 7.2/6.6/6.0	14.1/11.4/10.1/ 9.4/9.0/7.6	18.6/14.5/12.9/ 11.4/9.7/8.2	
Connection Type		Flare-nut Connection (with Flare Nuts)							
Piping	Liquid	mm	Φ6.35	Φ6.35	Φ6.35	Φ6.35	Φ6.35	Φ6.35	Φ9.53
		inch	1/4	1/4	1/4	1/4	1/4	1/4	3/8
	Gas	mm	Φ12.7	Φ12.7	Φ12.7	Φ12.7	Φ12.7	Φ15.88	Φ15.88
		inch	1/2	1/2	1/2	1/2	1/2	5/8	5/8
Condensate Drain	mm	I.D. Φ32							
Weight	Net Weight	kg	14.2	14.2	14.2	14.2	14.2	16.9	16.9
	Gross Weight	kg	18.2	18.2	18.2	18.2	18.2	21.6	21.6
Dimensions (H × W × D)	External	mm	129 × 910 × 470					129 × 1180 × 470	
	Packaging	mm	285 × 1145 × 582					285 × 1415 × 582	
Decoration Panel	Model		HP-D-NA1					HP-E-NA1	
	Panel Colour		Neutral White						
	External Dimensions (H × W × D)	mm	55 × 1100 × 550					55 × 1370 × 550	
	Net Weight	kg	5.3					6.4	

Notes:

1. The nominal cooling capacity is based on the following conditions:
 Indoor Air Inlet Temperature: 27°C DB (80°F DB), 19.0°C WB (66.2°F WB)
 Outdoor Air Inlet Temperature: 35°C DB (95°F DB)
 Piping Length: 7.5 Meters Piping Lift: 0 Meter
 Heating Operation Conditions
 Indoor Air Inlet Temperature: 20°C DB (68°F DB)
 Outdoor Air Inlet Temperature: 7°C DB (45°F DB), 6°C WB (43°F WB)

2. The sound pressure level is based on the following conditions: 1.0m beneath the unit, 1.0m from discharge grille. The above data are measured in an anechoic chamber so that the reflected sound should be taken into consideration in the field.

2-Way Cassette

Compact and Classy Design

The slim design of the unit, with a height as low as 298mm, allows for easy installation in tight ceiling spaces, such as corridors and other restricted areas.

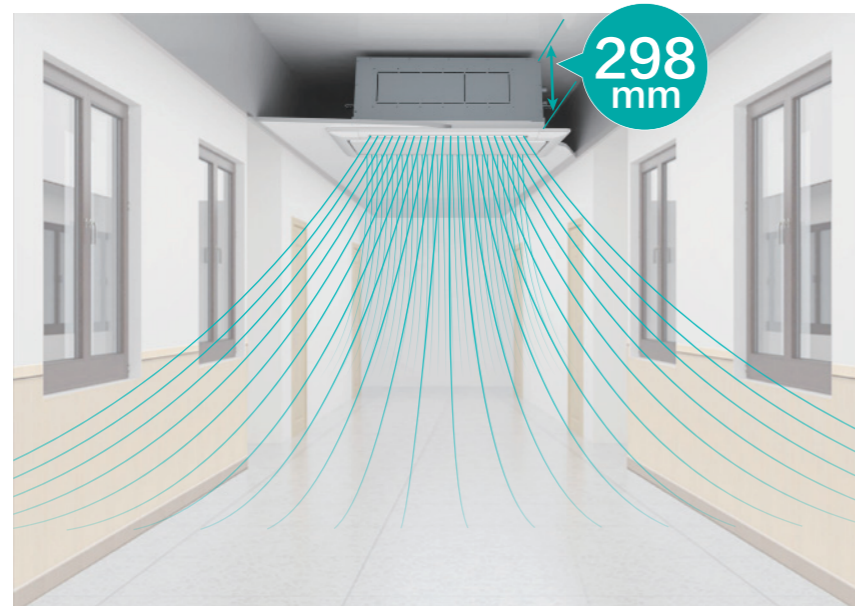

Independent Louvers Control

Each louver can be individually adjusted to one of seven angles, ranging from 27° to 84°. This feature is designed to meet the demands of spaces with high ceilings or narrow corridors, ensuring optimal airflow and adapting to various indoor layouts.

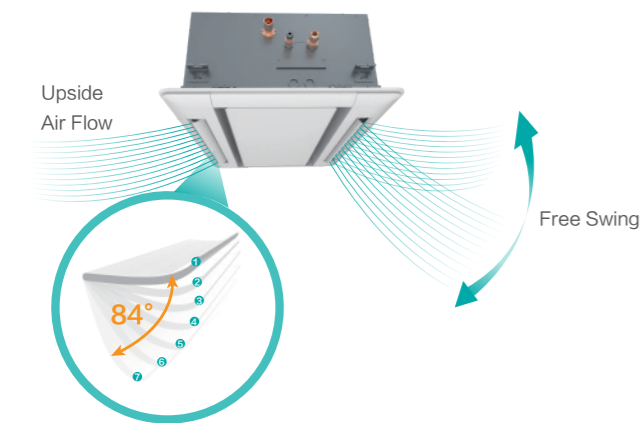

Branch Discharge Option

In irregular room layouts, branch discharge could come in handy by extending air distribution area to the most awkward corners without additional indoor units.

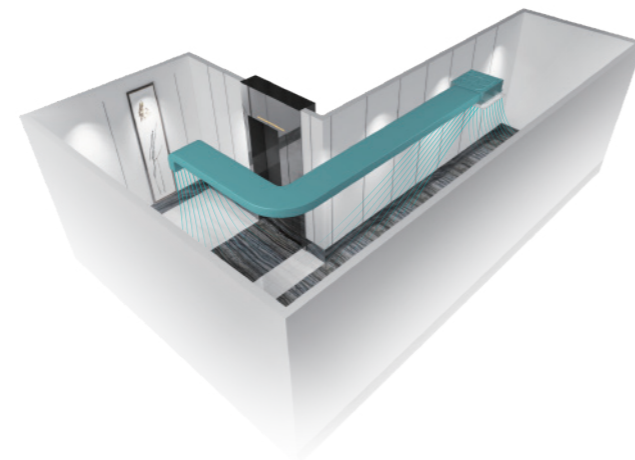

2-Way Cassette



Model	AVL-07 UXJSGA	AVL-09 UXJSGA	AVL-12 UXJSGA	AVL-14 UXJSGA	AVL-18 UXJSGA	AVL-24 UXJSGA	AVL-27 UXJSGA	AVL-30 UXJSGA	AVL-38 UXJSHA	AVL-48 UXJSHA	AVL-54 UXJSHA			
Power Supply	AC 1Φ, 220-240V/50Hz/60Hz													
Capacity	Cooling	kW	2.2	2.8	3.6	4.3	5.6	7.1	8.4	9.0	11.2	14.0	16.0	
		Btu/h	7,500	9,600	12,300	14,700	19,100	24,200	28,700	30,700	38,200	47,800	54,600	
Power Input	Cooling	kW	2.8	3.3	4.0	4.9	6.5	8.0	9.0	10.0	13.0	16.0	18.0	
		Btu/h	9,600	11,300	13,600	16,700	22,200	27,300	30,700	34,100	44,400	54,600	61,400	
Sound Pressure	Cooling	W	14	14	14	24	34	44	64	74	84	104	114	
		W	14	14	14	24	34	44	64	74	84	104	114	
Airflow Rate	Heating	dB(A)	32/30/ 29/27	33/30/ 29/28	34/31/ 30/28	40/37/ 34/32	42/39/ 36/33	45/42/ 40/36	47/44/ 40/36	49/46/ 42/37	46/44/ 40/38	48/45/ 42/38	49/46/ 43/40	
		m ³ /min	10.0/8.5/ 7.2/6.0	11.0/9.4/ 8.2/6.6	12.0/10.5/ 8.9/7.5	15.0/13.2/ 11.5/9.9	17.0/14.9/ 13.0/11.2	19.0/16.4/ 14.3/12.3	21.0/18.4/ 15.6/12.6	22.0/19.3/ 16.3/13.1	30.0/26.4/ 23.1/19.8	35.0/30.8/ 26.9/21.1	37.0/32.5/ 28.4/24.1	
Piping	Connection Type	mm	Flare-nut Connection (with Flare Nuts)											
		inch	φ6.35	φ6.35	φ6.35	φ6.35	φ6.35	φ9.53	φ9.53	φ9.53	φ9.53	φ9.53	φ9.53	
		mm	1/4	1/4	1/4	1/4	1/4	3/8	3/8	3/8	3/8	3/8	3/8	
		inch	φ12.70	φ12.70	φ12.70	φ12.70	φ12.70	φ15.88	φ15.88	φ15.88	φ15.88	φ15.88	φ15.88	
Weight	Condensate Drain	mm	I.D.32											
		kg	22	22	22	24	24	24	24	24	39	39	39	
Dimensions	External	H mm	298	298	298	298	298	298	298	298	298	298	298	
		W mm	860	860	860	860	860	860	860	860	1420	1420	1420	
		D mm	630	630	630	630	630	630	630	630	630	630	630	
	Packaging	H mm	350	350	350	350	350	350	350	350	350	350	350	
		W mm	1070	1070	1070	1070	1070	1070	1070	1070	1630	1630	1630	
		D mm	710	710	710	710	710	710	710	710	710	710	710	
Decoration Panel	Model	-	HP-C-NA	HP-C-NA	HP-C-NA	HP-C-NA	HP-C-NA	HP-C-NA	HP-C-NA	HP-C-NA	HP-F-NA	HP-F-NA		
		Panel Colour	Neutral White											
	Body Dimensions	H mm	30	30	30	30	30	30	30	30	30	30	30	
		W mm	1100	1100	1100	1100	1100	1100	1100	1100	1660	1660	1660	
		D mm	710	710	710	710	710	710	710	710	710	710	710	
	Packaging Dimensions	H mm	160	160	160	160	160	160	160	160	160	160	160	
		W mm	1170	1170	1170	1170	1170	1170	1170	1170	1710	1710	1710	
		D mm	740	740	740	740	740	740	740	740	740	740	740	
	Net Weight	kg	7.5	7.5	7.5	7.5	7.5	7.5	7.5	7.5	10.5	10.5	10.5	
		Gross Weight	kg	13.3	13.3	13.3	13.3	13.3	13.3	13.3	17.8	17.8	17.8	

Notes:

1. The nominal cooling capacity is based on the following conditions:
 Indoor Air Inlet Temperature: 27°C DB (80°F DB), 19.0°C WB (66.2°F WB)
 Outdoor Air Inlet Temperature: 35°C DB (95°F DB)
 Piping Length: 7.5 Meters Piping Lift: 0 Meter

2. The sound pressure level is based on the following conditions: 1.5m beneath the unit.
 The above data was measured in an anechoic chamber so that the reflected sound should be taken into consideration in the field.

Console

Stylish Design

The console unit is stylish with a sleek white cover, integrated LED indicators, and a temperature display. It is ideal for both residential and commercial applications where installation on or near the floor is required.

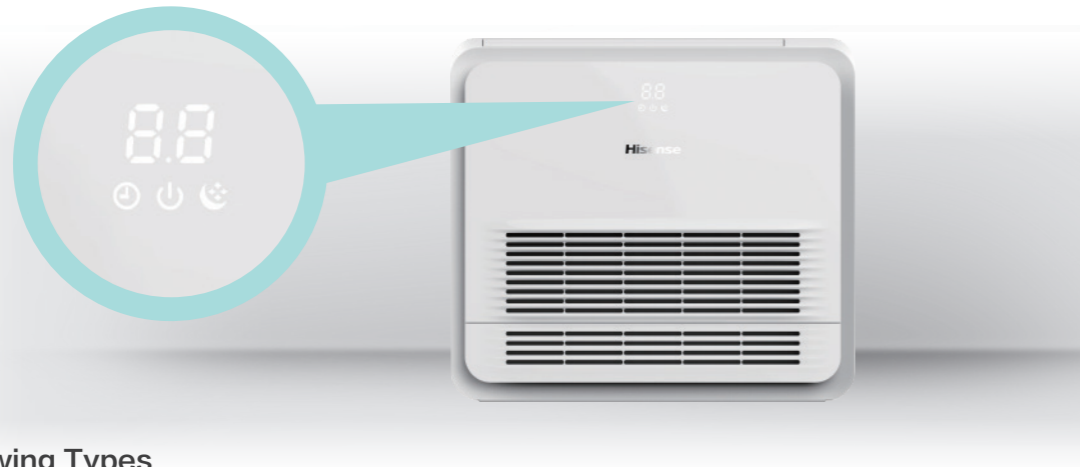

Multiple Blowing Types

Cooling Mode

The unit adopts the stereo cooling mode that can reach the setting temperature rapidly.



*Note: During cooling mode, the lower air louver will close automatically after the indoor unit operates in low fan speed mode for an hour. Otherwise it will keep open.

Heating Mode

Air supply through the below louver achieves floor heating effect and increases the comfort.



*Note: In the Eco mode, when the indoor return air temp. is close to the setting temp., the upper air deflector is automatically closed, and the lower air outlet mode is activated.

Flexible Installation Options

The unit can be placed on the floor or hung on the wall, and offers flexibility with surface-mounted, embedded, or concealed installation options.



Standing on the floor



Hanging on the wall



Surface mounted

Embedded

Concealed

Flexible Piping Connection

The refrigerant and drainage piping can be connected in any direction, including left, right, bottom, and back, providing extra installation flexibility.

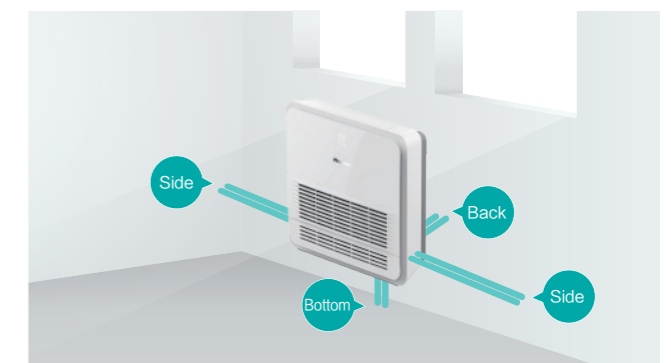

Console



Model		AVK-05HJFCAA	AVK-07HJFCAA	AVK-09HJFCAA	AVK-12HJFCAA	AVK-15HJFCAA	AVK-17HJFCAA	
Power Supply		AC 1ϕ, 220V~240V/50Hz/60Hz						
Capacity	Cooling	kW	1.5	2.2	2.8	3.6	4.5	5.0
		Btu/h	5,100	7,500	9,600	12,300	15,300	17,000
Capacity	Heating	kW	2.0	2.5	3.3	4.2	5.0	5.6
		Btu/h	6,800	8,500	11,200	14,300	17,000	19,100
Power Input	Cooling	W	10	11	12	14	18	23
	Heating	W	10	11	12	14	18	23
Sound Pressure	dB(A)	32/30/29/28/26/24	34/32/31/29/27/26	36/35/32/31/29/27	39/36/34/31/29/27	41/39/37/35/33/32	44/43/41/39/37/36	
Airflow Rate		m ³ /min	6.0/5.7/5.3/	7.4/7.0/6.4/	8.0/7.4/7.0/	8.2/7.6/6.8/	9.0/8.5/7.8/	10.1/9.7/9.0/
			5.1/4.7/4.5	6.0/5.6/5.3	6.4/6.0/5.6	6.2/5.7/5.3	7.2/6.6/6.4	8.5/7.9/7.3
Panel Colour	-	Pure White	Pure White	Pure White	Pure White	Pure White	Pure White	
Piping	Connection Type	-	Flare-nut Connection (with Flare Nuts)					
	Liquid	mm	ϕ 6.35	ϕ 6.35	ϕ 6.35	ϕ 6.35	ϕ 6.35	ϕ 6.35
Piping		inch	1/4	1/4	1/4	1/4	1/4	1/4
	Gas	mm	ϕ 12.70	ϕ 12.70	ϕ 12.70	ϕ 12.70	ϕ 12.70	ϕ 12.70
Piping		inch	1/2	1/2	1/2	1/2	1/2	1/2
	Condensate Drain	mm	O.D. 18					
Weight	Net Weight	kg	16.1	16.1	16.1	17.4	17.4	17.4
	Gross Weight	kg	20.6	21.1	21.1	21.5	21.5	21.5
Dimensions	External	H	mm	630	630	630	630	630
		W	mm	700	700	700	700	700
		D	mm	225	225	225	225	225
	Packaging	H	mm	725	725	725	725	725
		W	mm	790	790	790	790	790
		D	mm	315	315	315	315	315

Notes:

1. The nominal cooling capacity and heating capacity are based on the following conditions:
 Cooling Operation Conditions
 Indoor Air Inlet Temperature: 27°C DB (80°F DB), 19.0°C WB (66.2°F WB)
 Outdoor Air Inlet Temperature: 35°C DB (95°F DB)
 Piping Length: 7.5 Meters Piping Lift: 0 Meter
 Heating Operation Conditions
 Indoor Air Inlet Temperature: 20°C DB (68°F DB)
 Outdoor Air Inlet Temperature: 7°C DB (45°F DB), 6°C WB (43°F WB)

2. The sound pressure level is based on following conditions:
 It is measured in anechoic room. Operation noise differs with operation and ambient conditions.
 Location of Microphone:

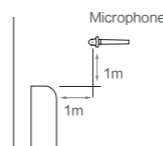

Ceiling Ducted (AC/DC Low Height)

Space Saving

Concealed AC/DC Low Height Ducted unit is as slim as 192mm, fitting into the narrowest ceiling spaces. Save ceiling spaces for higher room height without compromising user's comfort and satisfaction.

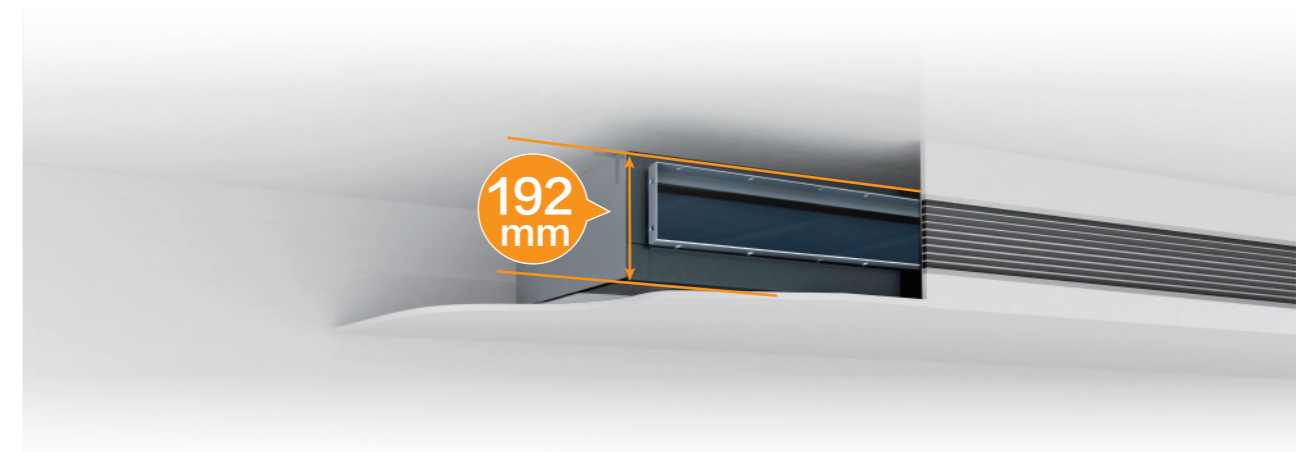

3D Air Flow

Classy air discharge louver panel with LED temperature and humidity display is available as an optional accessory for the AC low-height ceiling ducted units. The 3D louvers on the panel offer wide air flow coverage to keep every corners of your room cool or warm in any seasons of the year.

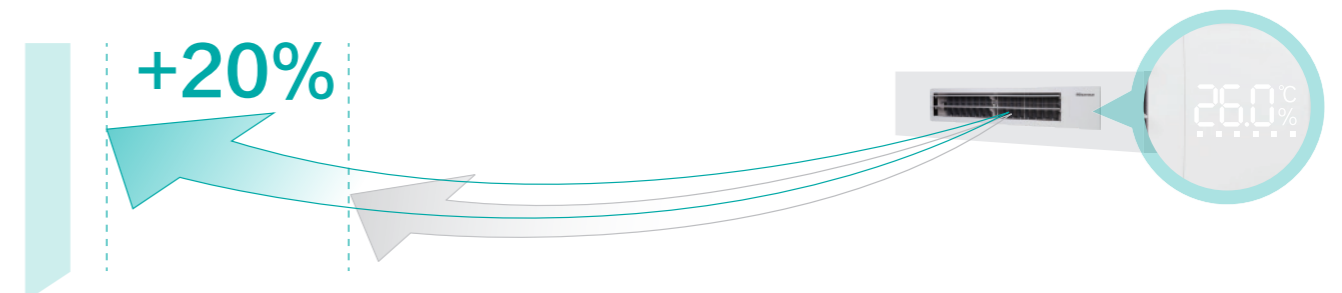
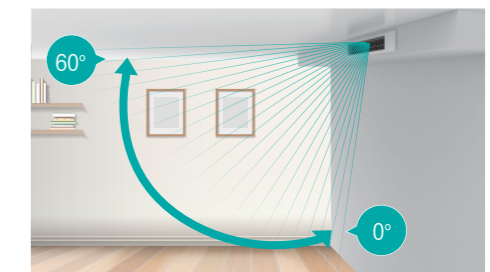
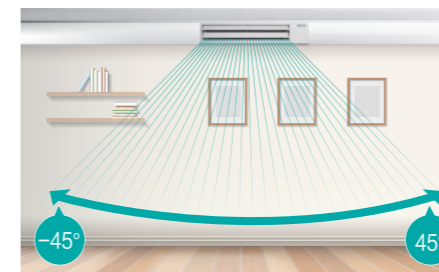

Ceiling Ducted (AC Low Height)



Model		AVE-05 HCFRL	AVE-07 HCFRL	AVE-09 HCFRL	AVE-12 HCFRL	AVE-15 HCFRL	AVE-17 HCFRL	AVE-19 HCFRL	AVE-22 HCFRL	AVE-24 HCFRL	
Power Supply		AC 1 φ, 220V~240V/50Hz									
Capacity	Cooling	kW	1.7	2.2	2.8	3.6	4.5	5.0	5.6	6.3	7.1
		Btu/h	5,800	7,500	9,600	12,300	15,300	17,100	19,100	21,500	24,200
	Heating	kW	1.9	2.5	3.2	4.0	5.0	5.6	6.3	7.1	8.0
		Btu/h	6,500	8,500	11,300	13,600	17,100	19,100	21,500	24,200	27,300
Power Input	Cooling	W	50	50	70	70	80	80	100	120	120
	Heating	W	50	50	70	70	80	80	100	120	120
Sound Pressure	dB(A)	29/24/22	29/24/22	35/25/23	35/25/23	36/25/23	36/25/23	35/25/23	39/26/25	39/26/25	
Airflow Rate	m³/min	7/5.5/4.7	7/5.5/4.7	9/5.7/4.8	9/5.7/4.8	12/6.3/5.5	12/6.3/5.5	13.5/8/7.7	18/9.3/8.7	18/9.3/8.7	
External Static Pressure	Pa	10(30)	10(30)	10(30)	10(30)	10(30)	10(30)	10(30)	10(30)	10(30)	
Piping	Connection Type	-	Flare-nut Connection (with Flare Nuts)								
	Liquid	mm	φ 6.35	φ 6.35	φ 6.35	φ 6.35	φ 6.35	φ 6.35	φ 6.35	φ 9.53	φ 9.53
		inch	1/4	1/4	1/4	1/4	1/4	1/4	1/4	3/8	3/8
	Gas	mm	φ 12.70	φ 12.70	φ 12.70	φ 12.70	φ 12.70	φ 12.70	φ 15.88	φ 15.88	φ 15.88
		inch	1/2	1/2	1/2	1/2	1/2	1/2	5/8	5/8	5/8
	Condensate Drain	mm	I.D.32								
Weight	Net Weight	kg	16	16	17	17	21	21	25	26	26
	Gross Weight	kg	19	19	20	20	24	24	29	29	29
Dimensions	External	H mm	192	192	192	192	192	192	192	192	192
		W mm	700	700	700	700	910	910	1180	1180	1180
		D mm	447	447	447	447	447	447	447	447	447
	Packaging	H mm	270	270	270	270	270	270	270	270	270
		W mm	925	925	925	925	1136	1136	1406	1406	1406
		D mm	574	574	574	574	574	574	574	574	574

Notes:

1. The nominal cooling capacity and heating capacity are based on the following conditions:
 Cooling Operation Conditions
 Indoor Air Inlet Temperature: 27°C DB (80°F DB), 19.0°C WB (66.2°F WB)
 Outdoor Air Inlet Temperature: 35°C DB (95°F DB)
 Piping Length: 7.5 Meters Piping Lift: 0 Meter
 Heating Operation Conditions
 Indoor Air Inlet Temperature: 20°C DB (68°F DB)
 Outdoor Air Inlet Temperature: 7°C DB (45°F DB), 6°C WB (43°F WB)

2. The sound pressure level is based on the following conditions: 1.5m beneath the unit.
 The above data was measured in an anechoic chamber so that the reflected sound should be taken into consideration in the field.

R32 | R410A

Ceiling Ducted (DC Low Height)



Model		AVE-05HJDDH	AVE-07HJDDH	AVE-09HJDDH	AVE-12HJDDH	AVE-15HJDDH	AVE-19HJDDH	AVE-24HJDDH	
Power supply		AC 1 φ, 220V~240V/50Hz/60Hz							
Capacity	Cooling	kW	1.7	2.2	2.8	3.6	4.5	5.6	7.1
		Btu/h	5,800	7,500	9,600	12,300	15,300	19,100	24,200
	Heating	kW	1.9	2.5	3.2	4.0	5.0	6.3	8.0
		Btu/h	6,500	8,500	11,300	13,600	17,100	21,500	27,300
Power Input	Cooling	W	30	30	50	50	60	60	90
	Heating	W	30	30	50	50	60	60	90
Sound Pressure	dB(A)	28/27/26/24/23/21	28/27/26/24/23/21	35/32/32/30/26/23	35/32/32/30/26/23	35/32/32/30/26/23	35/32/32/30/26/23	35/32/30/28/25/23	38/36/35/33/31/24
Air Flow Rate	m³/min	7.0/6.5/6.1/	7.0/6.5/6.1/	9.0/8.1/7.3/	9.0/8.1/7.3/6.7/	12.0/10.8/9.4/	13.5/12.5/11.2/	18.0/16.1/14.3/	
External Static Pressure	Pa	5.7/5.3/4.8	5.7/5.3/4.8	6.7/5.9/5.2	5.9/5.2	8.1/6.8/5.5	10.0/8.8/7.7	12.3/10.5/8.7	
External Static Pressure	Pa	10(10-30-50)							
Piping	Connection Type	-	Flare-nut Connection(with Flare Nuts)						
	Liquid	mm	φ6.35	φ6.35	φ6.35	φ6.35	φ6.35	φ6.35	φ9.53
		inch	1/4	1/4	1/4	1/4	1/4	1/4	3/8
	Gas	mm	φ12.7	φ12.7	φ12.7	φ12.7	φ12.7	φ15.88	φ15.88
		inch	1/2	1/2	1/2	1/2	1/2	5/8	5/8
	Condensate Drain	mm	I.D.32						
Weight	Net Weight	kg	16	16	17	17	20	24	24
	Gross Weight	kg	19	19	20	20	24	29	29
Dimensions	External	H mm	192	192	192	192	192	192	192
		W mm	700	700	700	700	910	1180	1180
		D mm	447	447	447	447	447	447	447
	Packaging	H mm	270	270	270	270	270	270	270
		W mm	925	925	925	925	1136	1406	1406
		D mm	574	574	574	574	574	574	574

Notes:

1. The nominal cooling capacity and heating capacity are based on the following conditions:
 Cooling Operation Conditions
 Indoor Air Inlet Temperature: 27°C DB (80°F DB), 19.0°C WB (66.2°F WB)
 Outdoor Air Inlet Temperature: 35°C DB (95°F DB)
 Piping Length: 7.5 Meters Piping Lift: 0 Meter
 Heating Operation Conditions
 Indoor Air Inlet Temperature: 20°C DB (68°F DB)
 Outdoor Air Inlet Temperature: 7°C DB (45°F DB), 6°C WB (43°F WB)

2. The sound pressure level is based on the following conditions: 1.5m beneath the unit.
 The above data was measured in an anechoic chamber so that the reflected sound should be taken into consideration in the field.

Ceiling Ducted(High/Low Static Pressure)

Adaptive Static Pressure&Constant Air Volume

The indoor unit automatically adjusts ESP by monitoring duct static pressure to ensure optimal air volume. During commissioning, the adaptive ESP function sets the most appropriate ESP value based on actual duct resistance, while the constant airflow function maintains stable air output over time.

	Adaptive Static Pressure	Constant Air Volume
Identification criteria	After the initial installation is completed	<ul style="list-style-type: none"> ① When the accumulated operation time reaches the preset cycle (100/200/400/600 hours) ② When indoor unit power exceeds the threshold in fan mode ③ After resetting the filter
Recognition frequency	One-time after installation	Periodic during operation
Air volume	Ensure rated air volume is reached after initial setting	Regular monitoring to maintain constant air volume throughout the operation

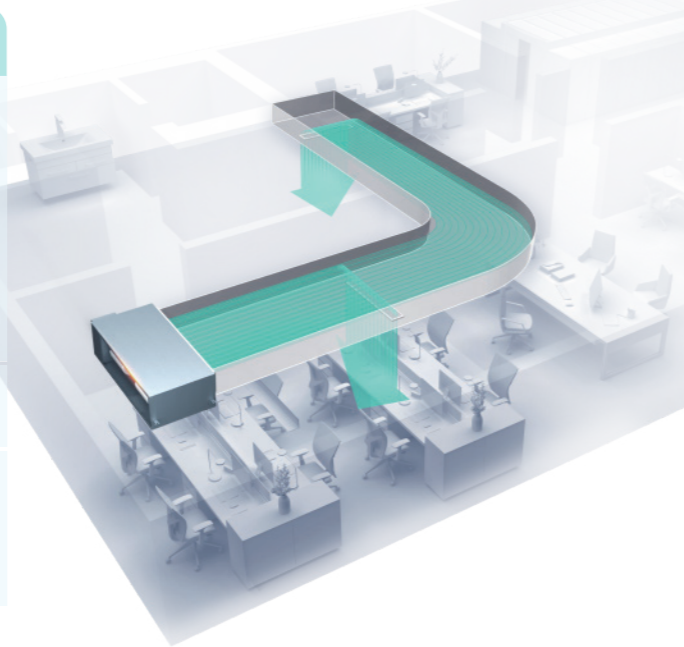

Comfort Cooling Mode

The indoor unit can achieve comfort cooling by setting three levels of air temperature (cooler/comfort/warmer)through the wired controller. The system compares the actual air temperature with the set temperature on the controller and intelligently adjusts its operating frequency to ensure a comfortable environment for the user.

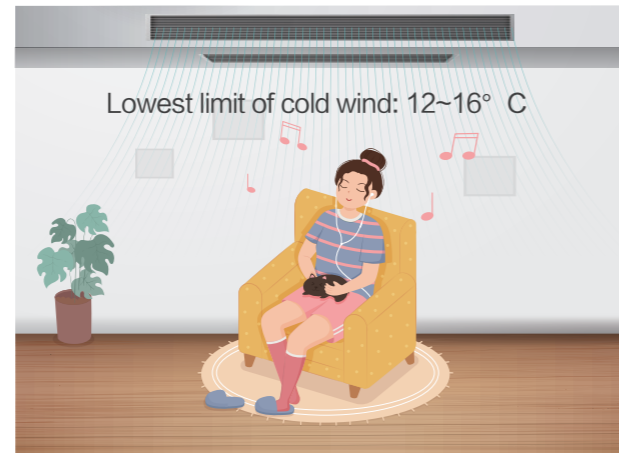

Various Device Connection Options

Third party devices to control the on-off air conditioners is possible with dry contact connections to the Indoor unit. Devices like room key card, window contact and fire alarms can be connected simultaneously.

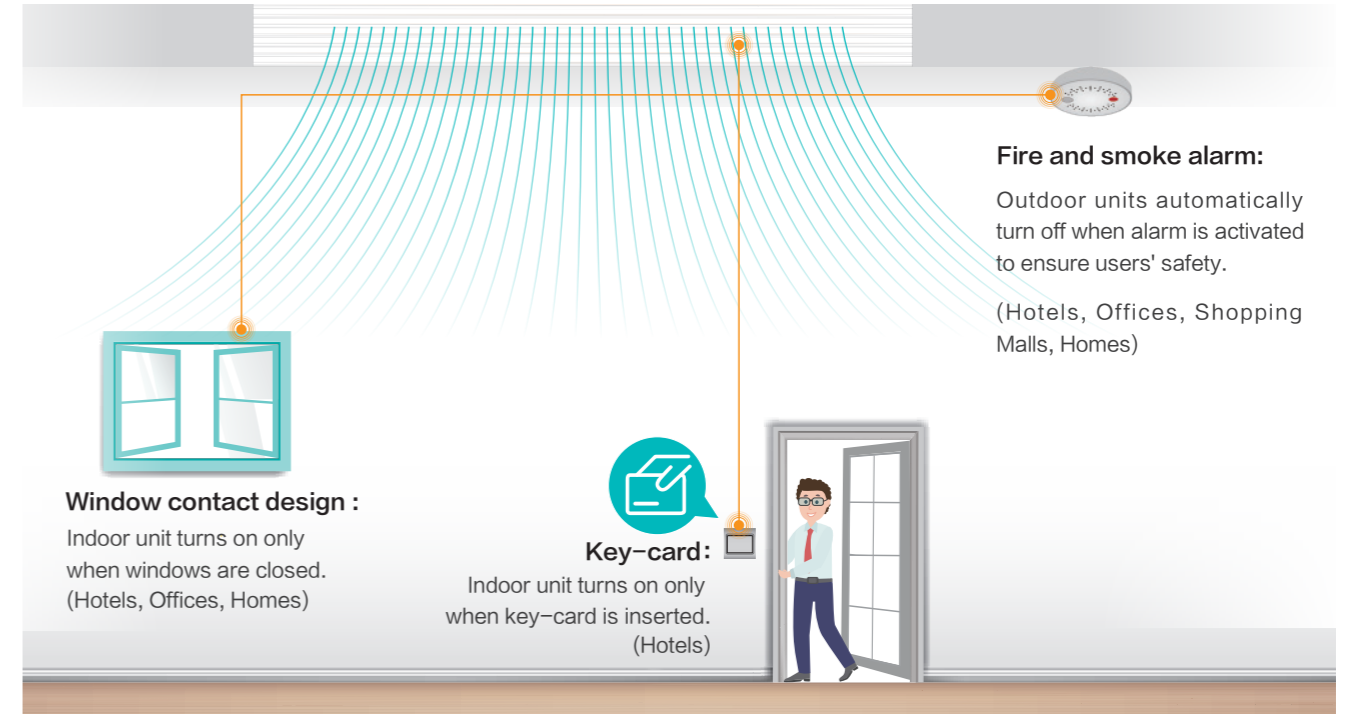

Precise Temperature Control

Two temperature sensor are installed into the unit to send real-time signals to the controllers for a more precise temperature control.



Hisense VRF

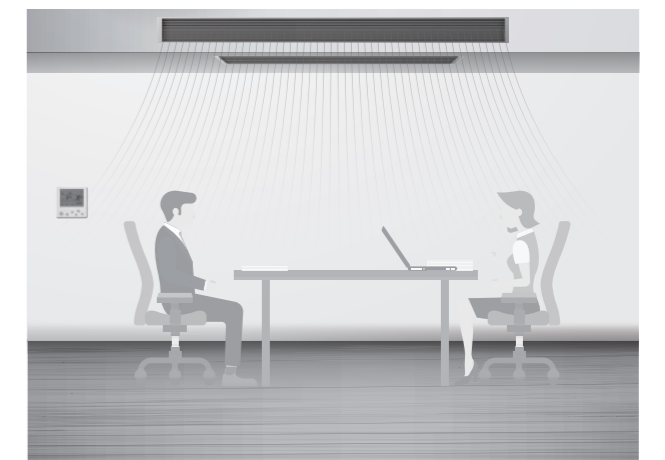

Conventional

Self-cleaning Function

The unit is featured with self-cleaning function. With just a press on the controller, the unit cleans itself automatically without manual intervention. It not only ensures clean and healthy air supply but also saves your valuable time and cost.



New Improved Bendable Filters

Standard filters that comes with high/low static pressure ceiling ducted are now optimized to be bendable by improving the material's malleability to improve installation flexibility in narrow ceiling height and restricted spaces.

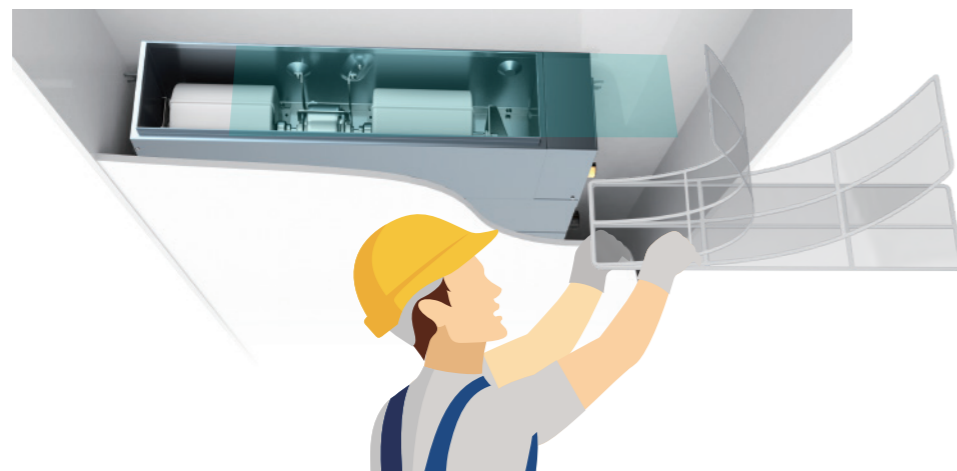

Fresh Air Introducing

There is a fresh air duct opening reserved in the unit for 10% free fresh air introduced directly from outdoor, providing fresh air to the indoor continuously.

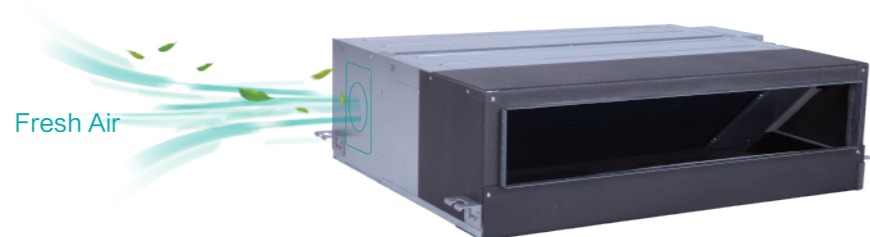

R32 | R410A

Ceiling Ducted (DC High Static Pressure)

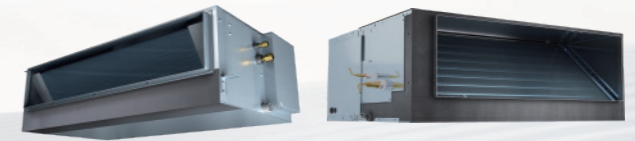

Model		AVD-07 HJDH	AVD-09 HJDH	AVD-12 HJDH	AVD-15 HJDH	AVD-19 HJDH	AVD-24 HJDH	AVD-24 HJDH1	AVD-30 HJDH	AVD-38 HJDH	AVD-42 HJDH	AVD-48 HJDH	AVD-54 HJDH	AVD-76 HJDH	AVD-96 HJDH	
Power Supply		AC 1ϕ, 220V~240V/50Hz/60Hz														
Capacity	Cooling	kW	2.2	2.8	3.6	4.5	5.6	7.1	7.1	9.0	11.2	12.5	14.0	16.0	22.4	28.0
		Btu/h	7,500	9,600	12,300	15,400	19,100	24,200	24,200	30,800	38,000	42,000	48,000	54,500	76,500	95,600
Capacity	Heating	kW	2.5	3.2	4.0	4.6	6.3	8.0	8.0	10.0	12.5	14	16.0	18.0	25.0	31.5
		Btu/h	8,500	10,900	13,700	17,100	21,600	27,400	27,400	34,200	42,500	48,000	54,500	61,500	85,300	107,500
Power Input	Cooling	W	40	40	55	55	55	82	74	100	132	180	180	223	610	830
	Heating	W	40	40	55	55	55	82	74	100	132	180	180	223	610	830
Sound Pressure Level	dB(A)	30/27/23/ 21/20/19	30/27/23/ 21/20/19	35/33/32/ 28/26/24	35/33/32/ 28/26/24	33/30/27/ 25/23/22	36/34/31/ 28/24/22	33/31/28/ 25/23/21	34/32/30/ 28/25/22	37/35/31/ 29/26/23	38/36/34/ 31/29/26	38/36/34/ 31/29/26	41/38/35/ 33/30/27	49/48/47/ 46/45/44	53/52/50/ 49/47/45	
Airflow Rate	m ³ /min	9/8/6.8/ 6.3/5.8/5.3	9/8/6.8/ 6.3/5.8/5.3	12/11/10/ 9/8/7.2	12/11/10/ 9/8/7.2	14.5/13/11.5/ 10.5/9.5/8.7	19/17/15/ 13/11/9.5	20.6/19/17/ 15/13.8/12.5	25/23/21/ 19/17/15	28/25/23/ 21/19/17	35.5/32.5/29.5/ 26.5/23.5/20.5	35.5/32.5/29.5/ 26.5/23.5/20.5	39/35.5/31/ 26.5/23.5/21.8	57/54/52/ 51/49/48	72/68/65/ 61/58/50	
External Static Pressure	Pa	30 (30/40/50/60/70/80/90/100/110/120/130/140/150)						50 (50/60/70/80/90/100/110/120/130/140/150/160/170/180/190/200)						150(50-250)	150(50-250)	
Piping	Connection Type	-	Flare-Nut Connection(With Flare Nut)										Brazing			
	Liquid	mm	ϕ6.35	ϕ6.35	ϕ6.35	ϕ6.35	ϕ6.35	ϕ9.53	ϕ9.53	ϕ9.53	ϕ9.53	ϕ9.53	ϕ9.53	ϕ9.53	ϕ9.53	ϕ9.53
		inch	1/4	1/4	1/4	1/4	1/4	3/8	3/8	3/8	3/8	3/8	3/8	3/8	3/8	3/8
	Gas	mm	ϕ12.7	ϕ12.7	ϕ12.7	ϕ12.7	ϕ15.88	ϕ15.88	ϕ15.88	ϕ15.88	ϕ15.88	ϕ15.88	ϕ15.88	ϕ15.88	ϕ22.2 (ϕ19.05 ^{*1})	ϕ22.2
inch		1/2	1/2	1/2	1/2	5/8	5/8	5/8	5/8	5/8	5/8	5/8	5/8	7/8 (3/4 ^{*1})	7/8	
Condensate Drain	-	I.D. 32														
Weight	Net Weight	kg	23	23	24	24	30	30	40	40	40	49	49	49	104	104
	Gross Weight	kg	29	29	30	30	37	37	48	48	48	57	57	57	125	125
Dimensions	External	H mm	270	270	270	270	270	270	300	300	300	300	300	300	470	470
		W mm	650+75	650+75	650+75	650+75	900+75	900+75	1100+75	1100+75	1100+75	1400+75	1400+75	1400+75	1250	1250
		D mm	720	720	720	720	720	720	800	800	800	800	800	800	1120	1120
	Packing	H mm	385	385	385	385	385	385	415	415	415	415	415	415	546	546
		W mm	895	895	895	895	1140	1140	1345	1345	1345	1640	1640	1640	1466	1466
		D mm	870	870	870	870	870	870	950	950	950	950	950	950	1270	1270

Notes:

- The nominal cooling capacity and heating capacity are based on the following conditions:
Cooling Operation Conditions
Indoor Air Inlet Temperature: 27° C DB(80° F DB), 19.0° C WB(66.2° F WB)
Outdoor Air Inlet Temperature: 35° C DB(95° F DB)
Heating Operation Conditions
Indoor Air Inlet Temperature: 20° C DB(68° F DB).
Outdoor Air Inlet Temperature: 7° C DB(45° F DB), 6° C WB(43° F WB)
Piping Length: 7.5 Meters Piping Lift: 0 Meter

- The sound pressure level is based on following conditions.
1.5m below the unit; With 2.0m discharge duct and 1.0m return duct
The above data were measured in an anechoic chamber so that reflected sound should be taken into consideration in the field.
- *1: The size of AVD-76° series gas pipe is ϕ22.2mm when leaving the factory, and the diameter can be changed to 19.05mm after welding the adapter pipe.

Ceiling Ducted (High Static Pressure)



Model	AVD-07 HCFCH	AVD-09 HCFCH	AVD-12H CFCH	AVD-15H CFCH	AVD-19 HCFCH	AVD-22 HCFCH	AVD-24 HCFCH	AVD-27 HCFCH	AVD-30 HCFCH	AVD-38 HCFCH	AVD-48 HCFCH	AVD-54 HCFCH		
Power Supply	AC 1 φ, 220V~240V/50Hz													
Model	AVD-07 H3FCH	AVD-09 H3FCH	AVD-12 H3FCH	AVD-15 H3FCH	AVD-19 H3FCH	AVD-22 H3FCH	AVD-24 H3FCH	AVD-27 H3FCH	AVD-30 H3FCH	AVD-38 H3FCH	AVD-48 H3FCH	AVD-54 H3FCH		
Power Supply	AC 1 φ, 208~230V/60Hz													
Capacity	Cooling	kW	2.2	2.8	3.6	4.5	5.6	6.3	7.1	8.0	9.0	11.2	14.0	16.0
		Btu/h	7,500	9,600	12,300	15,400	19,100	21,600	24,200	27,400	30,800	38,000	48,000	54,500
Capacity	Heating	kW	2.5	3.2	4.0	5.0	6.3	7.1	8.0	9.0	10.0	12.5	16.0	18.0
		Btu/h	8,500	10,900	13,700	17,100	21,600	24,200	27,400	30,800	34,200	42,500	54,500	61,500
Power Input	Cooling	kW	0.10(0.13 [*])	0.10(0.13 [*])	0.13(0.16 [*])	0.13(0.16 [*])	0.14(0.21 [*])	0.19(0.24 [*])	0.19(0.24 [*])	0.25(0.34 [*])	0.25(0.34 [*])	0.25(0.34 [*])	0.34(0.45 [*])	0.43(0.59 [*])
	Heating	kW	0.10(0.13 [*])	0.10(0.13 [*])	0.13(0.16 [*])	0.13(0.16 [*])	0.14(0.21 [*])	0.19(0.24 [*])	0.19(0.24 [*])	0.25(0.34 [*])	0.25(0.34 [*])	0.25(0.34 [*])	0.34(0.45 [*])	0.43(0.59 [*])
Sound Pressure	220~240V/50Hz	dB(A)	32/27/25	32/27/25	35/32/26	35/32/26	36/35/30	39/32/25	39/32/25	42/39/34	42/39/34	42/39/34	43/40/35	46/40/35
	208V/60Hz	dB(A)	33/28/24	33/28/24	37/34/29	37/34/29	37/35/29	39/32/25	39/32/25	42/38/33	42/38/33	42/38/33	44/39/34	45/40/34
	230V/60Hz	dB(A)	37/33/28	37/33/28	40/38/33	40/38/33	42/40/34	43/37/30	43/37/30	44/42/37	44/42/37	44/42/37	47/43/38	46/42/38
Air Flow(Hi/Me/Lo)	m ³ /min	9/7/6	9/7/6	12/10/8.5	12/10/8.5	15/13/10	19/14/10	19/14/10	28/24/19.5	28/24/19.5	28/24/19.5	35.5/29/24	39/31/24	
External Static Pressure	220~240V/50Hz 208V/60Hz	Pa	50(80)	50(80)	50(80)	50(80)	50(80)	50(80)	50(80)	120(90)	120(90)	120(90)	120(90)	
	230V/60Hz	Pa	80(105)	80(105)	90(115)	90(115)	90(115)	90(115)	90(115)	170(150)	170(150)	170(150)	170(150)	
Piping	Connection Type	-	Flare-nut Connection (with Flare Nuts)											
	Liquid	mm	φ 6.35	φ 6.35	φ 6.35	φ 6.35	φ 6.35	φ 9.53	φ 9.53	φ 9.53	φ 9.53	φ 9.53	φ 9.53	φ 9.53
		inch	1/4	1/4	1/4	1/4	1/4	3/8	3/8	3/8	3/8	3/8	3/8	3/8
	Gas	mm	φ 12.70	φ 12.70	φ 12.70	φ 12.70	φ 15.88	φ 15.88	φ 15.88	φ 15.88	φ 15.88	φ 15.88	φ 15.88	φ 15.88
		inch	1/2	1/2	1/2	1/2	5/8	5/8	5/8	5/8	5/8	5/8	5/8	5/8
Condensate Drain	mm	I.D.32												
Weight	Net Weight	kg	25(24 [*])	25(24 [*])	25(24 [*])	25(24 [*])	30(31 [*])	30(31 [*])	30(31 [*])	45(44 [*])	45(44 [*])	45(44 [*])	53(50 [*])	53(50 [*])
	Gross Weight	kg	29(30 [*])	29(30 [*])	31(30 [*])	31(30 [*])	37(38 [*])	37(38 [*])	37(38 [*])	52(52 [*])	52(52 [*])	52(52 [*])	62(59 [*])	62(59 [*])
Dimensions	External	H mm	270	270	270	270	270	270	270	300	300	300	300	300
		W mm	650+75	650+75	650+75	650+75	900+75	900+75	900+75	1100+75	1100+75	1100+75	1400+75	1400+75
		D mm	720	720	720	720	720	720	720	800	800	800	800	800
	Packaging	H mm	385	385	385	385	385	385	385	415	415	415	415	415
		W mm	895	895	895	895	1140	1140	1140	1345	1345	1345	1640	1640
		D mm	870	870	870	870	870	870	870	950	950	950	950	950

Notes:

1.The nominal cooling capacity and heating capacity are based on the following conditions:
Cooling Operation Conditions
Indoor Air Inlet Temperature: 27°C DB (80°F DB), 19.0°C WB (66.2°F WB)
Outdoor Air Inlet Temperature: 35°C DB (95°F DB)
Piping Length: 7.5 Meters Piping Lift: 0 Meter
Heating Operation Conditions
Indoor Air Inlet Temperature: 20°C DB (68°F DB)
Outdoor Air Inlet Temperature: 7°C DB (45°F DB), 6°C WB (43°F WB)

2. The sound pressure level is based on the following conditions: 1.5m beneath the unit.
With discharge duct (2.0m) and return duct (1.0m).
The above data was measured in an anechoic chamber so that the reflected sound should be taken into consideration in the field.

3. When bottom air inlet is adopted, the sound pressure will increase according to factors such as installation mode and the room structure.

*: The value noted * is the parameter of the indoor units with power supply 208~230V/60Hz.

Ceiling Ducted (Low Static Pressure)



Model	AVD-07 HCFCL	AVD-09 HCFCL	AVD-12 HCFCL	AVD-15 HCFCL	AVD-19 HCFCL	AVD-22 HCFCL	AVD-24 HCFCL	AVD-27 HCFCL	AVD-30 HCFCL	AVD-38 HCFCL	AVD-48 HCFCL	AVD-54 HCFCL		
Power Supply	AC 1 φ, 220V~240V/50Hz													
Capacity	Cooling	kW	2.2	2.8	3.6	4.5	5.6	6.3	7.1	8.0	9.0	11.2	14.0	16.0
		Btu/h	7,500	9,600	12,300	15,400	19,100	21,600	24,200	27,400	30,800	38,000	48,000	54,500
Capacity	Heating	kW	2.5	3.2	4.0	5.0	6.3	7.1	8.0	9.0	10.0	12.5	16.0	18.0
		Btu/h	8,500	10,900	13,700	17,100	21,600	24,200	27,400	30,800	34,200	42,500	54,500	61,500
Power Input	Cooling	W	60	60	110	110	90	160	160	240	240	240	290	360
	Heating	W	60	60	110	110	90	160	160	240	240	240	290	360
Sound Pressure	dB(A)	27/23/21	27/23/21	34/30/25	34/30/25	32/30/26	35/28/24	35/28/24	38/33/30	38/33/30	38/33/30	41/38/33	44/39/33	
Air Flow Rate (Hi/Me/Lo)	m ³ /min	9/7/6	9/7/6	12/10/8.5	12/10/8.5	15/13/10	19/14/10	19/14/10	28/24/19.5	28/24/19.5	28/24/19.5	35.5/29/24	39/31/24	
External Static Pressure	Pa	30	30	30	30	30	30	60	60	60	60	60		
Piping	Connection Type	-	Flare-nut Connection (with Flare Nuts)											
	Liquid	mm	φ 6.35	φ 6.35	φ 6.35	φ 6.35	φ 6.35	φ 9.53	φ 9.53	φ 9.53	φ 9.53	φ 9.53	φ 9.53	φ 9.53
		inch	1/4	1/4	1/4	1/4	1/4	3/8	3/8	3/8	3/8	3/8	3/8	3/8
	Gas	mm	φ 12.70	φ 12.70	φ 12.70	φ 12.70	φ 15.88	φ 15.88	φ 15.88	φ 15.88	φ 15.88	φ 15.88	φ 15.88	
		inch	1/2	1/2	1/2	1/2	5/8	5/8	5/8	5/8	5/8	5/8	5/8	
Condensate Drain	mm	I.D.32												
Weight	Net Weight	kg	25	25	25	25	30	30	30	45	45	45	52	52
	Gross Weight	kg	31	31	31	31	36	37	37	52	52	52	61	61
Dimensions	External	H mm	270	270	270	270	270	270	270	300	300	300	300	300
		W mm	650+75	650+75	650+75	650+75	900+75	900+75	900+75	1100+75	1100+75	1100+75	1400+75	1400+75
		D mm	720	720	720	720	720	720	720	800	800	800	800	800
	Packaging	H mm	385	385	385	385	385	385	385	415	415	415	415	415
		W mm	895	895	895	895	1140	1140	1140	1345	1345	1345	1640	1640
		D mm	870	870	870	870	870	870	870	950	950	950	950	950

Notes:

1.The nominal cooling capacity and heating capacity are based on the following conditions:
Cooling Operation Conditions
Indoor Air Inlet Temperature: 27°C DB (80°F DB), 19.0°C WB (66.2°F WB)
Outdoor Air Inlet Temperature: 35°C DB (95°F DB)
Piping Length: 7.5 Meters Piping Lift: 0 Meter
Heating Operation Conditions
Indoor Air Inlet Temperature: 20°C DB (68°F DB)
Outdoor Air Inlet Temperature: 7°C DB (45°F DB), 6°C WB (43°F WB)

2. The sound pressure level is based on the following conditions: 1.5m beneath the unit.
With discharge duct (2.0m) and return duct (1.0m).
The above data was measured in an anechoic chamber so that the reflected sound should be taken into consideration in the field.

3. When bottom air inlet is adopted, the sound pressure will increase according to factors such as installation mode and the room structure.

Wall Mounted

High-efficiency DC Fan Motor

Equipped with a DC fan motor, the unit significantly reduces the power consumption by 60% compared to conventional AC products, ensuring low-cost operation.

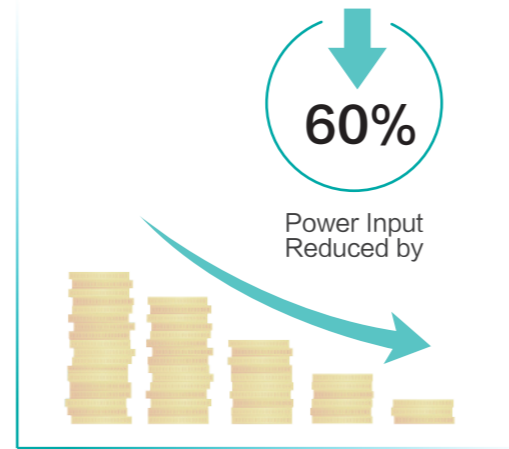

6 Fan Speed

6 indoor fan speeds are available to meet the needs of different indoor conditions.

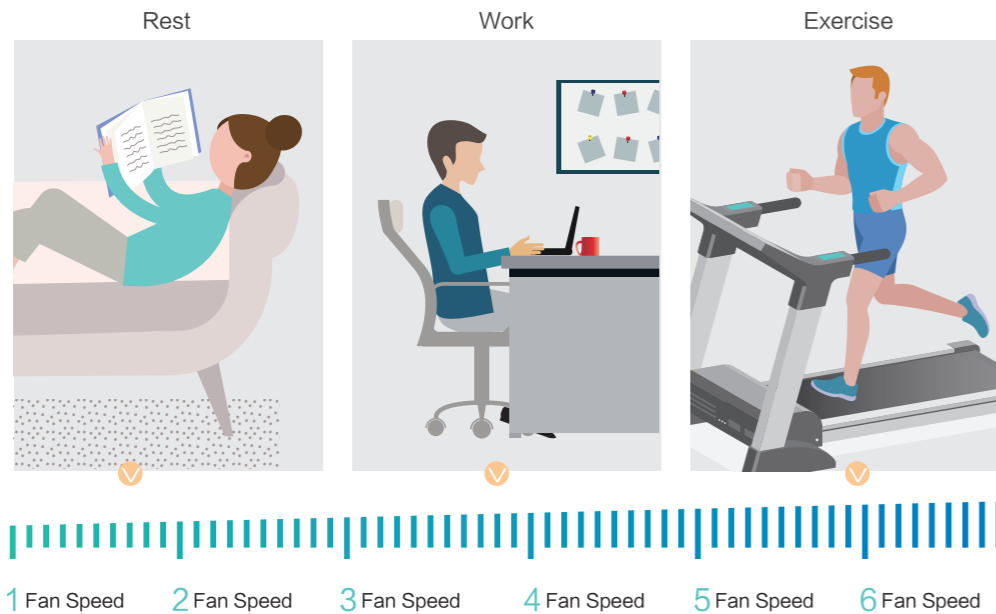

Self-cleaning Function

The unit is featured with self-cleaning function. With just a press on the controller, the unit cleans itself automatically without manual intervention. It not only ensures clean and healthy air supply but also saves your valuable time and cost.



R32 | R410A

Wall Mounted



Model		AVS-05 HJDTD	AVS-07 HJDTD	AVS-09 HJDTD	AVS-12 HJDTD	AVS-15 HJDTD	AVS-19 HJDTD	AVS-24 HJDTD	AVS-28 HJDTD		
Power Supply		AC 1ϕ, 220V~240V/50Hz/60Hz									
Capacity	Cooling	kW	1.7	2.2	2.8	3.6	4.5	5.6	7.1	8.4	
		Btu/h	5,800	7,500	9,600	12,300	15,400	19,100	24,200	28,700	
	Heating	kW	2.0	2.5	3.3	4.0	5.0	6.3	8.0	8.4	
		Btu/h	6,500	8,500	11,300	13,700	17,100	21,500	27,300	28,700	
Power Input	Cooling	W	20	20	20	30	20	30	50	80	
	Heating	W	20	20	20	30	30	30	70	80	
Sound Pressure		dB(A)	33/32/32/ 30/30/28	36/35/33/ 32/30/28	36/35/33/ 32/30/28	38/35/33/ 32/30/28	38/37/36/ 32/31/29	40/38/36/ 35/33/31	45/42/41/ 38/35/31	50/48/45/ 41/36/33	
	Airflow Rate	m ³ /min	8.7/8.3/8.2/ 7.5/7.2/7.0	9.8/9.2/8.7/ 8.2/7.5/7.0	9.8/9.2/8.7/ 8.2/7.5/7.0	10.3/9.2/8.7/ 8.2/7.5/7.0	11.5/11.0/10.3/ 9.0/8.7/8.0	16.2/15.0/14.2/ 13.3/12.2/11.5	20.0/18.0/17.0/ 15.0/13.3/11.7	23.3/22.0/20.0/ 17.0/14.2/12.2	
Panel Colour		White									
Piping	Connection Type		Flare-nut Connection(with Flare Nuts)								
	Liquid	mm	ϕ6.35	ϕ6.35	ϕ6.35	ϕ6.35	ϕ6.35	ϕ9.53	ϕ9.53	ϕ9.53	
		inch	1/4	1/4	1/4	1/4	1/4	3/8	3/8	3/8	
	Gas	mm	ϕ9.53	ϕ9.53	ϕ9.53	ϕ9.53	ϕ12.7	ϕ15.88	ϕ15.88	ϕ15.88	
inch		3/8	3/8	3/8	3/8	1/2	5/8	5/8	5/8		
Condensate Drain		O.D. 22									
Weight	Net Weight	kg	9.5	9.5	9.5	9.5	13.0	14.4	14.4	14.4	
	Gross Weight	kg	13.4	13.4	13.4	13.4	17.8	19.4	19.4	19.4	
Dimensions	External Dimension	H	mm	270	270	270	270	315	315	315	315
		W	mm	845	845	845	845	960	1120	1120	1120
		D	mm	203	203	203	203	230	230	230	230
	Packaging Dimension	H	mm	375	375	375	375	430	430	430	430
		W	mm	943	943	943	943	1058	1223	1223	1223
		D	mm	310	310	310	310	328	328	328	328

Notes:

1. The rated capacity is based on the following conditions:

Cooling conditions: indoor air inlet temperature: 27°C DB, 19°C WB, outdoor air inlet temperature: 35°C DB, pipe length: 7.5m, pipe height difference: 0m.
Heating conditions: indoor air inlet temperature: 20°C DB, outdoor air inlet temperature: 7°C DB, 6°C WB, pipe length: 7.5m, pipe height difference: 0m.

2. The above noise values are measured in an anechoic chamber so that reflected sound should be taken into consideration during actual operation.

The above noise values are measured under the fan mode operation, and measured at a point 1m in front of the unit and 0.8m below the unit.

Floor Standing

3D Air Flow

The adjustable louvers allows for independent control, delivering 3D airflow both vertically and horizontally to reach every corner of the room.



22m Air Supply

Maximum 22m long-distance air supply can be achieved at high fan speed. You can choose from high, medium, low, or auto fan speed modes to cater to different needs.



Self-cleaning Function

Featured with self-cleaning technology, the evaporator can be self-cleaned automatically, preventing the dust and potentially harmful substances from accumulating on the surface of the heat exchanger. Thus the air blown from the air conditioner is clean and healthy.



Flexible Installation

Piping can be connected in three directions: left, right, and rear, offering flexible positioning and simple installation.



Model		AVF-36H2FDA	AVF-48H2FDA	AVF-56H2FDA	AVF-96H2FDA		
Power Supply		AC 1 Φ, 220V~240V/50Hz/60Hz					
Capacity	Cooling	kW	11.2	14.0	16.0	28.0	
		Btu/h	38,000	48,000	54,500	95,500	
	Heating	kW	12.5	16.0	18.0	31.0	
		Btu/h	42,500	54,500	61,500	105,700	
Power Input	Cooling	W	58	174	282	797	
	Heating	W	58	174	282	797	
Sound Pressure	dB(A)	41/39/37	51/47/43	56/54/51	62/60/57		
Air Flow Rate	m ³ /min	26.7/25.3/22.2	40/35.7/31.3	45.8/42.5/40	83.2/70.7/61		
Piping	Connection Type	-	Flare-nut Connection(with Flare Nuts)			Brazing	
	Liquid	mm	Φ9.53	Φ9.53	Φ9.53	Φ9.53	
		inch	3/8	3/8	3/8	3/8	
	Gas	mm	Φ15.88	Φ15.88	Φ15.88	Φ22.2	
		inch	5/8	5/8	5/8	7/8	
	Condensate Drain	mm		VP16		RC1 (I.D. 25.4)	
Weight	Net Weight	kg	59	59	59	136	
	Gross Weight	kg	71	71	71	152	
Dimensions	External	H	mm	1928	1928	1928	1850
		W	mm	665	665	665	1200
		D	mm	415	415	415	425
	Packaging	H	mm	2065	2065	2065	2010
		W	mm	800	800	800	1260
		D	mm	530	530	530	490

Notes:

1. The rated capacity is based on the following conditions:
 Cooling conditions: indoor air inlet temperature: 27°C DB, 19°C WB, outdoor air inlet temperature: 35°C DB, pipe length: 7.5m, pipe height difference: 0m.
 Heating conditions: indoor air inlet temperature: 20°C DB, outdoor air inlet temperature: 7°C DB, 6°C WB, pipe length: 7.5m, pipe height difference: 0m.

2. The above noise values are measured in an anechoic chamber so that reflected sound should be taken into consideration during actual operation.

Ceiling & Floor

Sleek Design

The glossy white cover panel features a smooth and elegant design. The bolts and nuts used for mounting the unit on the wall or ceiling are concealed, ensuring seamless integration into the room's interior.



Flexible Installation

The unit can be installed either on the floor or mounted on the ceiling.



Convenient Installation and Maintenance

You can effortlessly adjust the installation height by opening the side panel. With duct connections and the electrical box located behind the return air panel, maintenance is also easier.

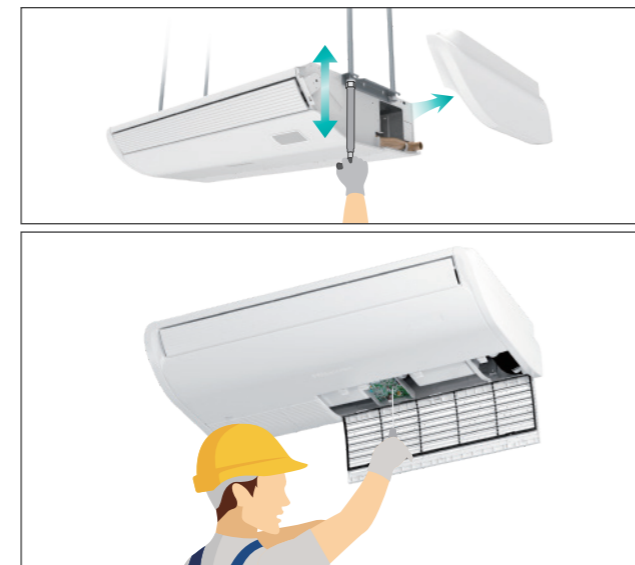

Wide Air Supply

Louvers consist of horizontal and vertical slats to cover larger coverage area to every corner. Wider opening angle from up to 120° for vertical louvers and up to 71° for horizontal louvers supplies air further and lower down to floor.

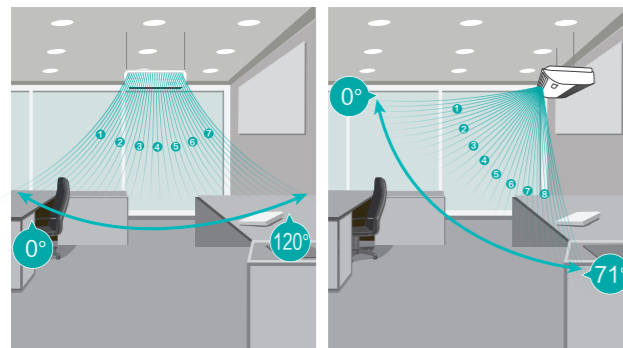

Ceiling & Floor



Model		AVV-17URSCA	AVV-18URSCA	AVV-22URSCA	AVV-24URSCA	AVV-27URSCB	AVV-30URSCB	AVV-38URSCB	AVV-48URSCC		
Power Supply		AC 1Φ, 220V~240V/50Hz/60Hz									
Capacity	Cooling	kW	5.0	5.6	6.3	7.1	8.4	9.0	11.2	14.2	
		Btu/h	17,100	19,100	21,500	24,200	28,700	30,700	38,200	48,500	
	Heating	kW	5.6	6.5	7.5	8.5	9.6	10.0	13.0	16.3	
		Btu/h	19,100	22,200	25,600	29,000	32,800	34,100	44,400	55,600	
Power Input	Cooling	W	40	40	70	70	70	80	130	160	
	Heating	W	40	40	70	70	70	80	130	160	
Sound Pressure	Ceiling	dB(A)	39/35/30	39/35/30	45/41/37	45/41/37	43/39/34	45/40/36	51/46/40	50/46/42	
	Floor	dB(A)	43/38/35	43/38/35	48/44/40	48/44/40	46/41/37	48/43/39	54/49/43	55/50/46	
Airflow Rate	m ³ /min	13.0/11.0/9.0	13.0/11.0/9.0	16.1/14.0/11.3	16.1/14.0/11.3	18.2/15.2/12.2	19.4/16.3/13.3	24.8/20.5/16.3	33.0/28.0/23.0		
Speed-up Setting HH1	m ³ /min	14.2	14.2	17.8	17.8	19.8	21.2	27.0	36.0		
Speed-up Setting HH2	m ³ /min	16.0	16.0	20.0	20.0	22.3	23.5	29.2	37.4		
Panel Colour		Neture White									
Piping	Connection Type		Flare-nut Connection (with Flare Nuts)								
	Liquid	mm	φ 6.35	φ 6.35	φ 9.53	φ 9.53	φ 9.53	φ 9.53	φ 9.53	φ 9.53	
		inch	1/4	1/4	3/8	3/8	3/8	3/8	3/8	3/8	
	Gas	mm	φ 15.88	φ 15.88	φ 15.88	φ 15.88	φ 15.88	φ 15.88	φ 15.88	φ 15.88	
		inch	5/8	5/8	5/8	5/8	5/8	5/8	5/8	5/8	
Condensate Drain	mm	I.D.32									
Weight	Net Weight	kg	33	33	34	34	41	41	41	49	
	Gross Weight	kg	38	38	39	39	46	47	48	56	
Dimensions	External	H mm	230	230	230	230	230	230	230	230	
		W mm	990	990	990	990	1285	1285	1285	1580	
	Packaging	H mm	340	340	340	340	340	340	340	340	
		W mm	1110	1110	1110	1110	1400	1400	1400	1690	
	D mm	830	830	830	830	830	830	830	830		

Notes:

1. The nominal cooling capacity and heating capacity are based on the following conditions:
 Cooling Operation Conditions
 Indoor Air Inlet Temperature: 27°C DB (80°F DB), 19.0°C WB (66.2°F WB)
 Outdoor Air Inlet Temperature: 35°C DB (95°F DB)
 Piping Length: 7.5 Meters Piping Lift: 0 Meter
 Heating Operation Conditions
 Indoor Air Inlet Temperature: 20°C DB (68°F DB)
 Outdoor Air Inlet Temperature: 7°C DB (45°F DB), 6°C WB (43°F WB)

2. The sound pressure level is based on the following conditions:
 1.0m beneath the unit, 1.0m from Discharge Grille.
 The above data was measured in an anechoic chamber so that the reflected sound should be taken into consideration in the field. When bottom air inlet is adopted, sound pressure will increase according to factors such as installation mode and the room structure.

Floor Concealed

Space Saving

Floor concealed units are designed to be installed on floors completely concealed into the walls which designed to be slim and compact with only height of 620mm to be hidden under half-heighted windows.



Adjustable Static Pressure and Flexible Installation

With 2-level external static pressure adjustable, project design and installation are more flexible. Users can choose the air duct to increase the air supply distance in order to achieve the completely concealed installation.

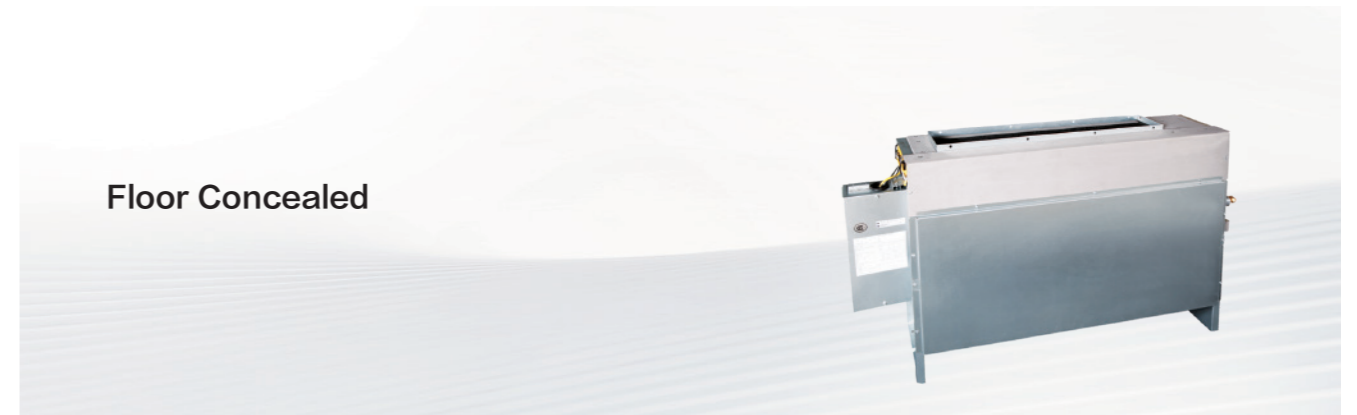
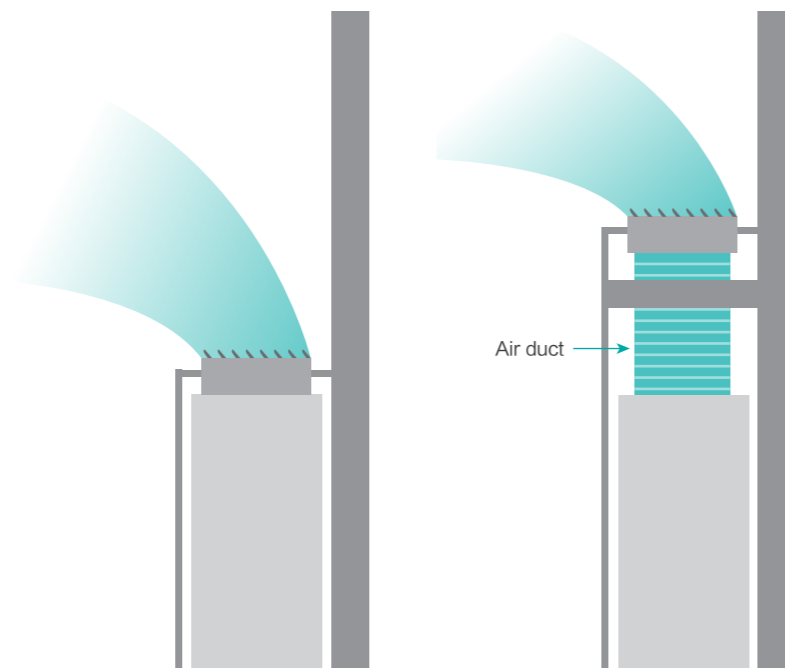

Model		AVH-09UXCSAA	AVH-14UXCSAA	AVH-18UXCSBA	AVH-24UXCSBA	
Power Supply		AC 1Φ, 220V-240V/50Hz				
Model		AVH-09UX2SAA	AVH-14UX2SAA	AVH-18UX2SBA	AVH-24UX2SBA	
Power Supply		AC 1Φ, 220V/60Hz				
Capacity	Cooling	kW	2.8	4.3	5.6	7.1
		Btu/h	9,600	14,700	19,100	24,200
Capacity	Heating	kW	3.3	4.9	6.5	8.5
		Btu/h	11,300	16,700	22,200	29,000
Power Input	Cooling	W	50	80	90	120
	Heating	W	50	80	90	120
Sound Pressure		dB(A)	34/31/27	40/36/34	41/36/32	44/40/36
Airflow Rate		m ³ /min	8.5/7.5/6.3	10.3/9.0/8.0	14.8/12.3/10.5	16.3/13.8/11.8
Piping	Connection Type	-	Flare-nut Connection (with Flare Nuts)			
	Liquid	mm	φ 6.35	φ 6.35	φ 6.35	φ 9.53
		inch	1/4	1/4	1/4	3/8
	Gas	mm	φ 12.70	φ 12.70	φ 15.88	φ 15.88
		inch	1/2	1/2	5/8	5/8
	Condensate Drain	mm	I.D.32			
Weight	Net Weight	kg	18	22	26	27
	Gross Weight	kg	30	31	37	37
Dimensions	External	H mm	620	620	620	620
		W mm	948+139	948+139	1218+139	1218+139
		D mm	202	202	202	202
	Packaging	H mm	675	675	675	675
		W mm	1160	1160	1430	1430
		D mm	240	240	240	240

Notes:

1. The nominal cooling capacity and heating capacity are based on the following conditions:
 Cooling Operation Conditions
 Indoor Air Inlet Temperature: 27°C DB (80°F DB), 19.0°C WB (66.2°F WB)
 Outdoor Air Inlet Temperature: 35°C DB (95°F DB)
 Piping Length: 7.5 Meters Piping Lift: 0 Meter
 Heating Operation Conditions
 Indoor Air Inlet Temperature: 20°C DB (68°F DB)
 Outdoor Air Inlet Temperature: 7°C DB (45°F DB), 6°C WB (43°F WB)

2. The sound pressure level is based on the following conditions:
 1.5m meters from the unit and 1.5m meters from floor level.
 The above data was measured in an anechoic chamber so that reflected sound should be taken into consideration in the field.

All Fresh Air Indoor Unit

Multiple Fan Speeds

Equipped with a DC motor, our system offers three-level fan speeds that can be flexibly adjusted to suit different indoor conditions.

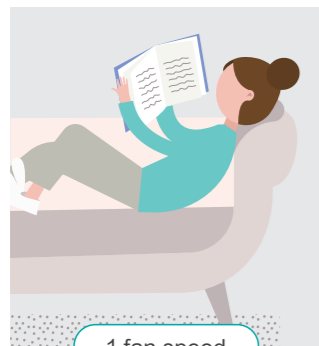

1 fan speed

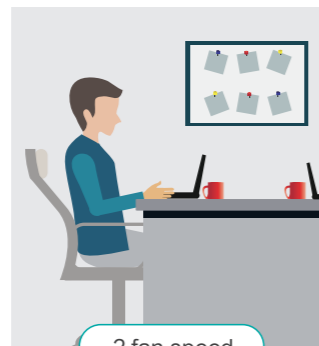

2 fan speed

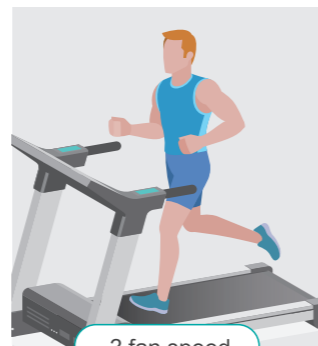

3 fan speed

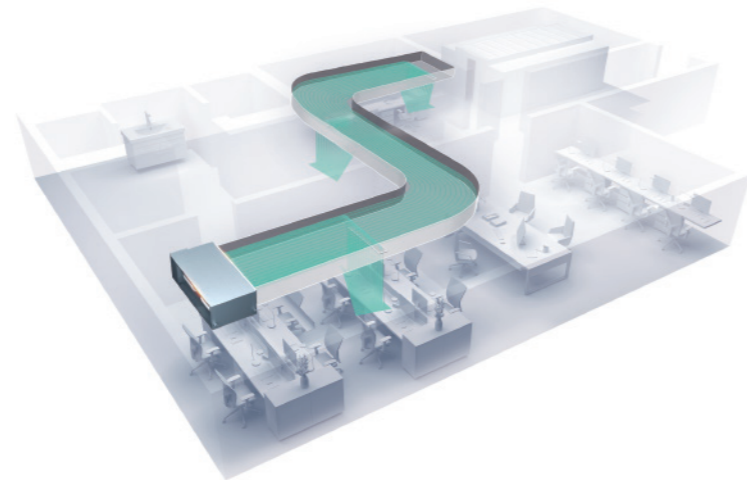

Adjustable Static Pressure

Three static pressure modes can be adjusted to meet the needs of different air supply distance, making installation more flexible and effectively sends conditioned air to every corner of the room.

Self-cleaning Function

Featured with self-cleaning technology, the evaporator can be self-cleaned automatically, preventing the dust and potentially harmful substances from accumulating on the surface of the heat exchanger. It ensures that the air blown from the air conditioner is clean and healthy.



PM2.5 Filter Box (Optional)

Equipped with a high-performance filter box, our air conditioning system removes impurities from outdoor air, ensuring the air you breathe is cleaner and healthier. Besides, the filter box is designed for easy maintenance and replacement, allowing for seamless system operation.

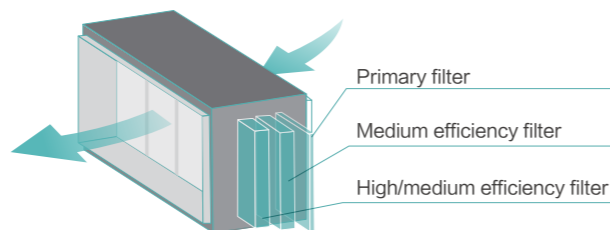

All Fresh Air Indoor Unit

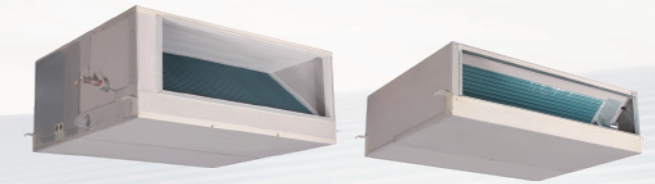

Model			AVA-48HJFDL-108	AVA-76HJFDL-168	AVA-96HJFDL-210	AVA-114HJFDL-300
Power Supply			AC 1Φ,220V~240V/50Hz/60Hz			
Capacity	Cooling	kW	14.0	22.4	28.0	33.5
		Btu/h	47,800	76,500	95,600	114,400
	Heating	kW	13.7	21.9	24.5	26.4
		Btu/h	46,800	74,800	83,600	90,100
Power Input	Cooling	W	190	311	421	721
	Heating	W	190	311	421	721
Sound Pressure		dB(A)	42	46	48	49
Airflow Rate		m ³ /min	18.0/15.6/13.3	28.0/23.2/18.3	35.0/31.7/26.7	50.0/41.7/33.3
External Static Pressure		Pa	150(150-200-250)	150(150-200-250)	150(150-200-250)	150(150-220-300)
Piping	Connection Type		Flare-Nut Connection (with Flare Nuts)		Brazing	
	Liquid	mm	φ9.53	φ9.53	φ9.53	φ12.70
		inch	3/8	3/8	3/8	1/2
	Gas	mm	φ15.88	φ19.05	φ22.20	φ25.40
		inch	5/8	3/4	7/8	1
	Condensate Drain		mm	I.D. 32		
Weight	Net Weight	kg	56	107	108	108
	Gross Weight	kg	62	124	125	125
Dimensions	External	H mm	320	484	484	484
		W mm	790	1072	1072	1072
		D mm	1420	1269	1269	1269
	Packaging	H mm	420	1213	1213	1213
		W mm	1650	1450	1450	1450
		D mm	955	530	530	530

Notes:

- The nominal cooling capacity and heating capacity are based on following conditions: Cooling operation conditions: 35°C DB, 28°C WB, piping length: 7.5m, piping lift: 0m. Heating operation conditions: 0°C DB, -3°C WB, piping length: 7.5m, piping lift: 0m. (Heating capacity is tested when defrosting is not available.)
- The sound pressure level is based on following conditions: 1.4m beneath the unit. The above data was measured in an anechoic chamber so that reflected sound should be taken into consideration in the field.
- In case of connecting the all fresh air type indoor unit with other indoor units in the same refrigerant cycle, the total capacity of all fresh air type indoor unit shall not exceed 30% of the rated capacity of VRF outdoor unit.
- When the outdoor unit is connected only with all fresh air type indoor unit, the combination ratio is 80 - 100%.

RELIABILITY
EFFICIENCY
COMFORT
FLEXIBILITY
OUTDOOR UNIT
INDOOR UNIT
CONTROL SYSTEM
ACCESSORY

Heat Recovery Ventilator

Compact Machine, Convenient Installation

Its compact design facilitates easy installation in narrow ceilings. With a width of only 600mm (for units with an airflow rate under 300m³/h), it is perfect for the tight ceiling spaces.

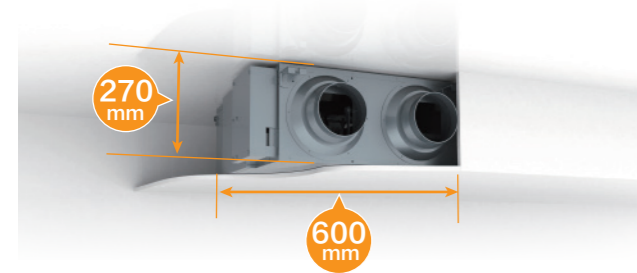

Airflow System

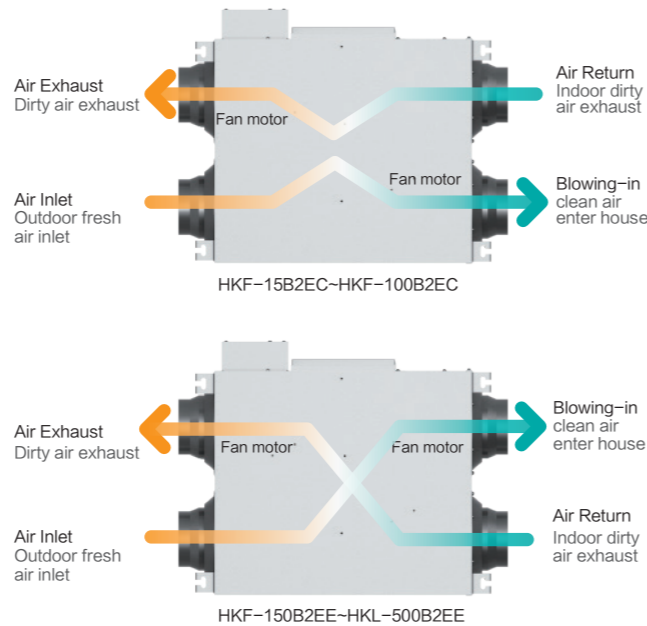

Energy Saving Analysis

Summer Energy Saving Analysis

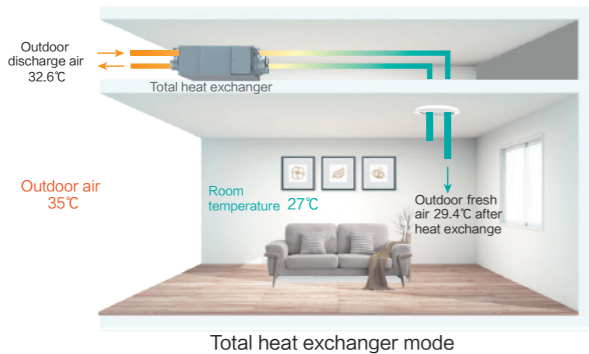

In summer operation, when the cold energy of 27°C air discharged from indoor pass through the heat exchanger, the 35°C outdoor hot air is pre-cooled to 29.4°C fresh air and supplied to indoors, as shown above, the air conditioner only needs to cool the air by 2.4°C to maintain a comfortable room temperature and fresh air. In this process, the discharge air pre-cools the fresh air by HRV, The temperature recovery efficiency in cooling is 70% max, and enthalpy exchange efficiency is 57% max.

Winter Energy Saving Analysis

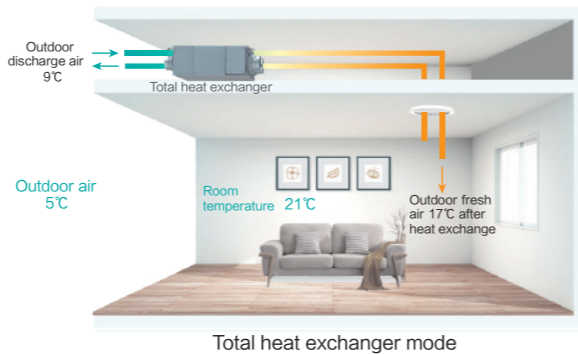

In winter operation, when the heat energy of 21°C air discharged from indoor pass through the heat exchanger, the 5°C outdoor cold air is pre-heated to 17°C fresh air and supplied to indoors, as shown above, when outdoor 5°C air and indoor 21°C air pass through the HRV, the fresh air supplied to indoors is about 17°C, the air conditioner only needs to heat the air by 4°C to maintain a comfortable room temperature and fresh air. The temperature recovery efficiency in heating is 75% max, and enthalpy exchange efficiency is 63% max.

Heat Recovery Ventilator

Centralized Control System

Hisense heat recovery ventilator can be connected to the Hisense VRF Central Control System, achieving the central control from Hisense VRF controllers. The operation is more convenient and more intelligent.

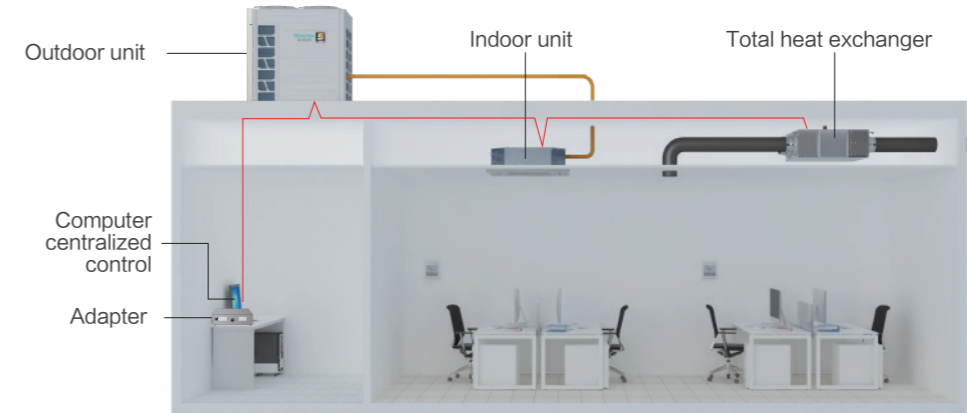

HKF-15B2EC

Product Dimensions

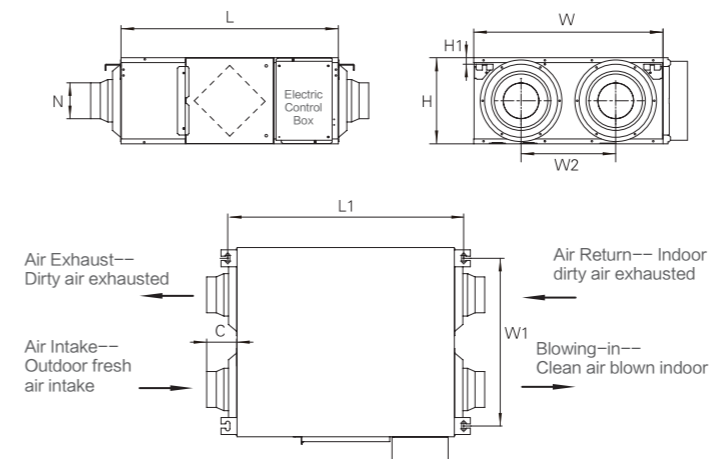

Model	L	L1	W	W1	W2	H	C	N	H1
HKF-15B2EC*	665	723	580	514	290	265	90	φ144	20

Technical Parameters

Model	Air Volume m ³ /h			Enthalpy Efficiency (Summer) η _i			Enthalpy Efficiency (Winter) η _i			External Static Pressure Pa			Power Supply	Input Current A			Input Power kW			Noise Level dB(A)			Weight kg
	High	Middle	Low	High	Middle	Low	High	Middle	Low	High	Middle	Low		High	Middle	Low	High	Middle	Low				
HKF-15B2EC*	150	150	110	58	58	60	65	65	69	85	70	65	220-240V/50Hz	0.38	0.36	0.31	2 × 0.041	2 × 0.038	2 × 0.029	30	29	28	25

*: 220V/60Hz HKF-15B2E2

HKF-25B2EC~HKF-100B2EC

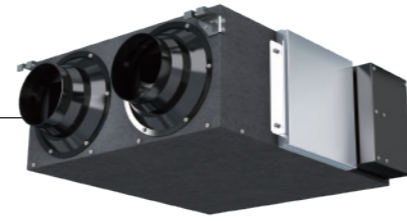

Product Dimensions

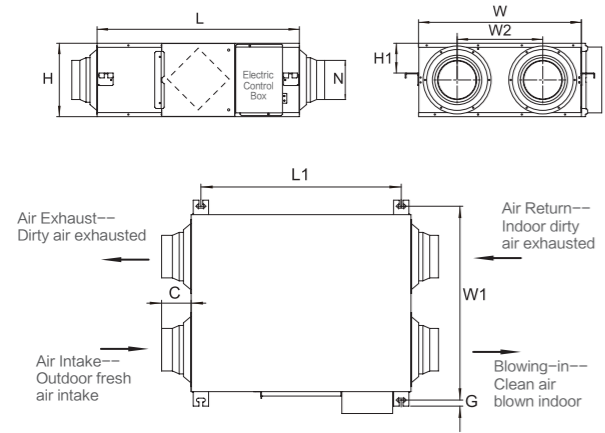

Model	L	L1	W	W1	W2	H	C	G	N	H1
HKF-25B2EC*	745	675	600	656	315	270	90	19	φ144	110
HKF-35B2EC*	745	675	805	861	480	270	90	19	φ144	110
HKF-50B2EC*	825	755	905	961	500	270	96	19	φ194	110
HKF-65B2EC*	1115	1050	885	941	430	390	80	19	φ242	175
HKF-80B2EC*	1115	1050	1135	1191	675	390	80	19	φ242	175
HKF-100B2EC*	1115	1050	1135	1191	675	390	80	19	φ242	175

Technical Parameters

Model	Air Volume m³/h			Enthalpy Efficiency (Summer) η _i			Enthalpy Efficiency (Winter) η _i			External Static Pressure Pa			Power Supply	Input Current A			Input Power kW			Noise Level dB(A)			Weight kg
	High	Middle	Low	High	Middle	Low	High	Middle	Low	High	Middle	Low		High	Middle	Low	High	Middle	Low	High	Middle	Low	
HKF-25B2EC*	250	250	190	57	57	59	63	63	68	85	65	60	220-240V 50Hz	0.66	0.56	0.52	2×0.069	2×0.055	2×0.049	32	31	28	30
HKF-35B2EC*	350	350	270	55	55	57	62	62	65	100	75	65		0.76	0.75	0.71	2×0.083	2×0.079	2×0.075	34	33	31	35
HKF-50B2EC*	500	500	400	56	56	58	63	63	65	130	110	100		1.82	1.71	1.52	2×0.189	2×0.157	2×0.124	39	38	36	40
HKF-65B2EC*	650	650	550	57	57	59	63	63	68	130	100	100		1.75	1.62	1.51	2×0.193	2×0.178	2×0.164	40	38	35	62
HKF-80B2EC*	800	800	650	58	58	59	66	66	68	130	100	90		1.98	1.88	1.75	2×0.211	2×0.196	2×0.18	42	40	37	72
HKF-100B2EC*	1000	1000	700	56	56	58	63	63	66	165	120	60		4.68	4.18	3.47	2×0.510	2×0.450	2×0.363	44	42	38	79

*: AC 1Φ, 220V/60Hz HKF-25B2E2~HKF-100B2E2

HKF-150B2EE~HKF-200B2EE

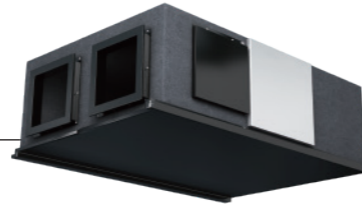

Product Dimensions

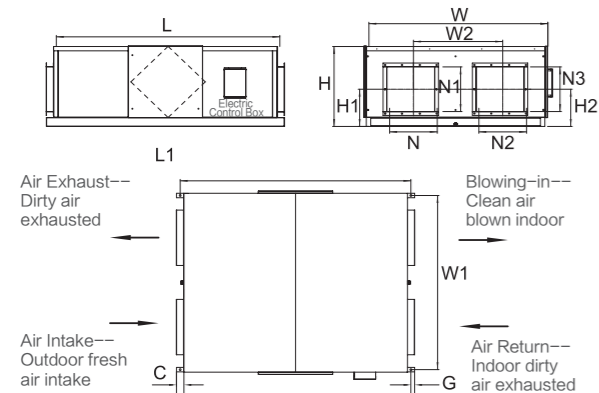

Model	L	L1	W	W1	W2	H	H1
HKF-150B2EE*	1500	1550	1200	1170	600	540	250
HKF-200B2EE*	1550	1600	1400	1370	700	540	250

Model	C	G	N	N1	N2	N3	H2
HKF-150B2EE*	50	25	320	300	320	300	250
HKF-200B2EE*	50	25	320	300	320	300	250

Technical Parameters

Model	Air Volume m³/h	Enthalpy Efficiency (Summer) η _i	Enthalpy Efficiency (Winter) η _i	External Static Pressure Pa	Power Supply	Input Current A	Input Power kW	Noise Level dB(A)	Weight kg
HKF-150B2EE*	1500	55	63	180	380-415V/50Hz	2.78	2×0.41	48	151
HKF-200B2EE*	2000	54	62	160	380-415V/50Hz	2.89	2×0.52	49	172

*: AC 3Φ, 220V/60Hz HKF-150B2E9 HKF-200B2E9

AC 3Φ, 380V/60Hz HKF-150B2EF HKF-200B2EF

HKF-250B2EE~HKF-300B2EE



Product Dimensions

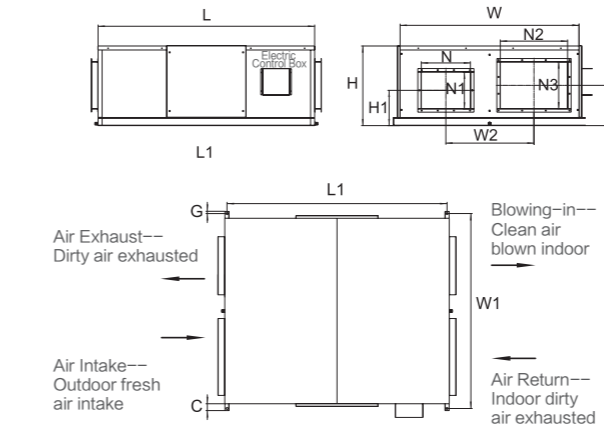

Model	L	L1	W	W1	W2	H	H1
HKF-250B2EE*	1610	1580	1330	1400	655	600	265
HKF-300B2EE*	1700	1670	1500	1570	750	640	272

Model	C	G	N	N1	N2	N3	H2
HKF-250B2EE*	50	15	365	275	500	350	300
HKF-300B2EE*	50	15	365	275	500	350	309

Technical Parameters

Model	Air Volume m³/h	Enthalpy Efficiency (Summer) η _i	Enthalpy Efficiency (Winter) η _i	External Static Pressure Pa	Power Supply	Input Current A	Input Power kW	Noise Level dB(A)	Weight kg
HKF-250B2EE*	2500	54	62	180	380-415V/50Hz	3.86	2×0.72	53	185
HKF-300B2EE*	3000	55	63	200	380-415V/50Hz	5.12	2×1.16	56	222

*: AC 3Φ, 220V/60Hz HKF-250B2E9 HKF-300B2E9 AC 3Φ, 380V/60Hz HKF-250B2EF HKF-300B2EF

HKL-400B2EE~HKL-500B2EE



Product Dimensions

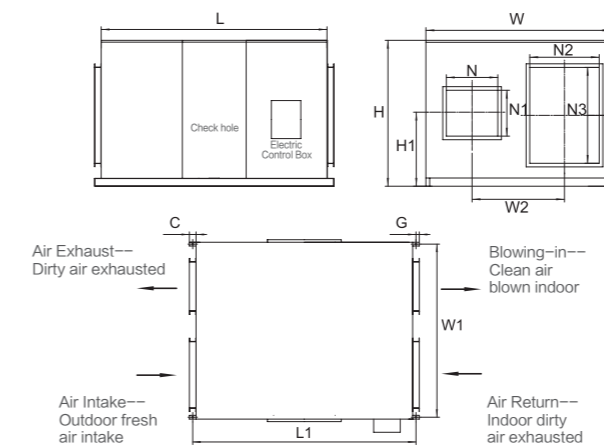

Model	L	L1	W	W1	W2	H	H1
HKL-400B2EE*	1625	1675	1330	1300	665	1050	490
HKL-500B2EE*	1625	1675	1330	1300	665	1050	490

Model	C	G	N	N1	N2	N3	H2
HKL-400B2EE*	50	25	370	330	500	690	475
HKL-500B2EE*	50	25	370	330	500	690	475

Technical Parameters

Model	Air Volume m³/h	Enthalpy Efficiency (Summer) η _i	Enthalpy Efficiency (Winter) η _i	External Static Pressure Pa	Power Supply	Input Current A	Input Power kW	Noise Level dB(A)	Weight kg
HKL-400B2EE*	4000	55	63	220	380-415V/50Hz	5.89	2×1.71	57	312
HKL-500B2EE*	5000	53	61	240	380-415V/50Hz	8.78	2×2.2	58	321

*: AC 3Φ, 220V/60Hz HKL-400B2E9 HKL-500B2E9 AC 3Φ, 380V/60Hz HKL-400B2EF HKL-500B2EF

RELIABILITY

EFFICIENCY

COMFORT

FLEXIBILITY

OUTDOOR UNIT

INDOOR UNIT

CONTROL SYSTEM

ACCESSORY

AHU Connection KIT

The Hisense AHU-kit integrates external heat exchangers of Air-handling units (AHU) into a Hisense VRF system to provide more flexible air conditioning solutions.

Main Function

- ON/OFF Control
- Temperature Setting
- Capacity Demand
- Operation Mode

— Communication wire — Sensor signal — Refrigerant pipe

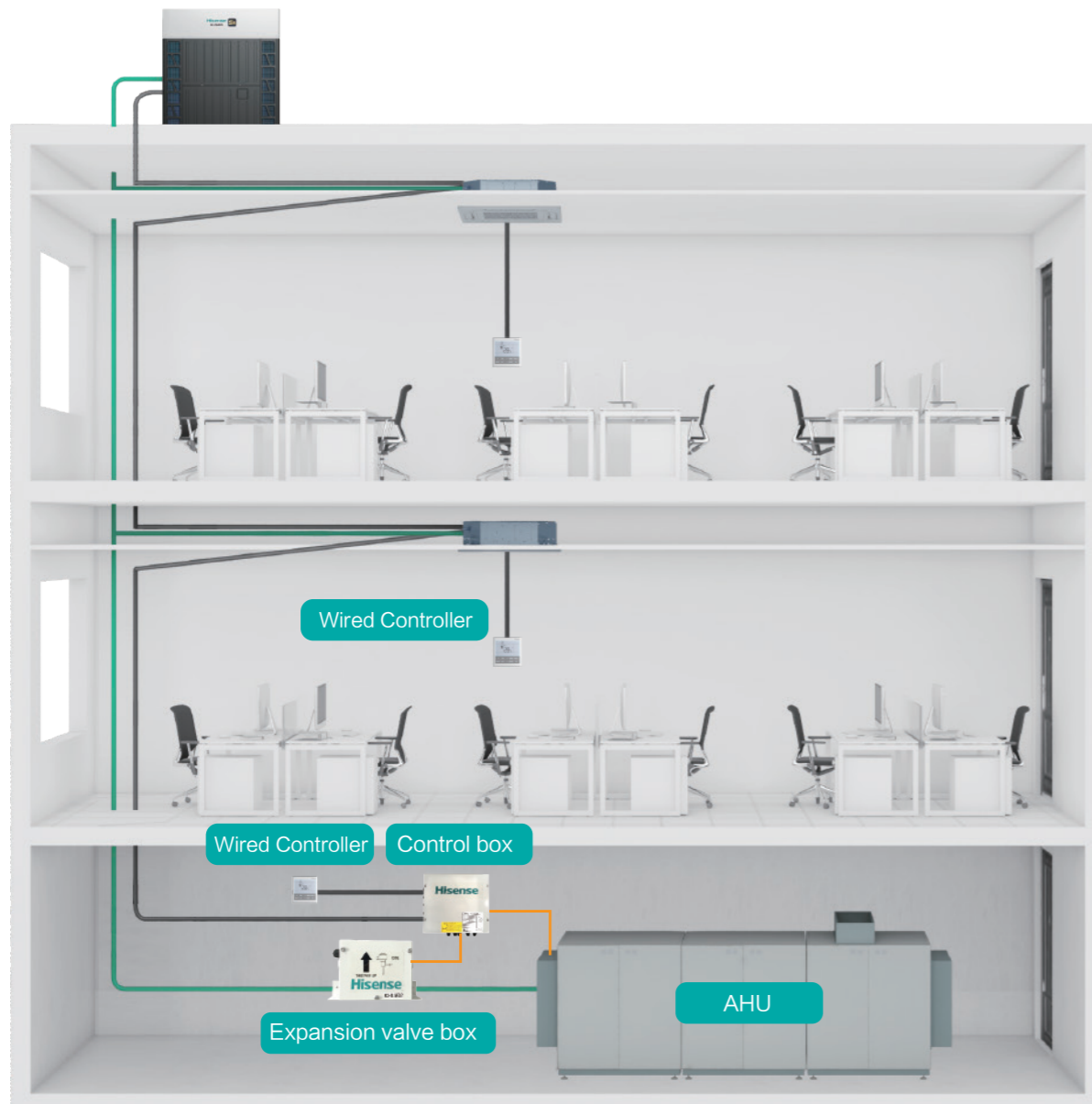

AHU Connection KIT

AHU kit can provide 3 kinds of control type for AHU application: Inlet air temperature control, outlet air temperature control and duty signal control.

Capacity Control Mode	Set Temperature by Remote Controller	Set ODU Capacity Range
Inlet Air (room air) Temperature Control	Cooling: 16~32 °C Heating: 16~32 °C	—
Outlet Air Temperature Control		
Duty Signal Control (0~10V or 0~5V or 4~20mA)	—	15%~100%

AHU Connection KIT	R410A	HZX-2 BEJ	HZX-4 BEJ	HZX-6 BEJ	HZX-10BEJ	HZX-20BEJ						HZX-30BEJ					
	R32	HZX-2 BEJD	HZX-4 BEJD	HZX-6 BEJD	HZX-10BEJD	HZX-20BEJD						HZX-30BEJD					
Model Power Supply	AC 1Φ,220~240V/50Hz/60Hz																
Nominal Capacity of AHU	HP	2	4	6	8	10	12	14	16	18	20	22	24	26	28	30	
Allowed Heat Exchanger Capacity (H/M/L)	Cooling	kW	4.0	7.1	11.2	16.0	20.0	28.0	33.5	40.0	45.0	50.0	56.0	61.5	69.0	73.0	80.0
		kW	5.0	9.0	14.0	20.0	25.0	30.0	35.0	43.0	48.0	52.0	58.0	65.0	71.0	76.0	82.0
	Heating	kW	5.6	11.2	16.0	22.4	28.0	33.5	40.0	45.0	50.0	56.0	61.5	69.0	73.0	80.0	85.0
		kW	4.5	8.0	12.5	17.9	22.4	31.5	37.5	45.0	50.0	56.0	63.0	69.0	77.5	82.5	90.0
Heat Exchanger Volume	Min	dm³	0.57	1.03	1.92	2.92	3.89	4.76	5.85	6.79	7.57	8.47	9.04	9.50	10.39	11.39	12.36
	Max	dm³	1.16	2.37	2.92	3.89	4.76	5.91	6.89	8	8.92	9.97	11.13	12.34	12.89	13.86	14.73
Equivalent Indoor Unit Capacity	HP	2	4	6	8	10	12	14	16	18	20	22	24	26	28	30	
Control Box Model	R410A	HZX-BEJ/1															
	R32	HZX-BEJD/1															
Expansion Valve Box Model	R410A	HZX-2 BEJ/2	HZX-4 BEJ/2	HZX-6 BEJ/2	HZX-10BEJ/2	HZX-20BEJ/2						HZX-30BEJ/2 2set					
	R32	HZX-2 BEJD/2	HZX-4 BEJD/2	HZX-6 BEJD/2	HZX-10BEJD/2	HZX-20BEJD/2						HZX-30BEJD/2 2set					

Operation conditions		Cooling	Heating
Indoor air inlet temperature	DB	27.0°C	20.0°C
	WB	19.0°C	-
Outdoor air inlet temperature	DB	35.0°C	7.0°C
	WB	-	6.0°C

DB: dry bulb; WB: wet bulb
Pipe Length: 7.5m; pipe height: 0m

CONTROL SYSTEM



Individual Control

Centralized Control

Intelligent Control

AIR
CONDITIONING
SOLUTION

Overview

Model	Wired Controller HYXE-VC01	Wired Controller HYXM-VG01	Wired Controller HYXE-VA01A	Wired Controller HYXE-S01H	Wireless Controller HYE-VD01
Picture					
Max. connectable indoor units	6	16	16	16	—
Power supply	15V	15V	15V	15V	3V
Dimension(mm)	86*86	120*120	120*120	120*70	178.6*47.8
Cool/Heat/Fan/Auto/Dry	●	●	●	●	●
Auto dehumidification(humidity sensor)	●	●	●	●	×
Fan speed	●	●	●	●	●
Louver setting	●	●	●	●	●
Temperature setting	●	●	●	●	●
Operation monitoring	●	●	●	●	×
Timer	●	●	●	●	●
7-day timer	×	●	×	×	×
Holiday setting	×	●	×	×	×
Main-sub connection	●	×	●	×	×
Main-sub control	×	●	×	×	×
Change indoor address	●	●	●	×	×
Check function	●	●	●	●	×
Option setting	●	●	●	●	×
Air filter cleaning reminding	●	●	●	●	×
Error code display	●	●	●	●	×
Auto test run	●	●	●	●	●
Indoor/outdoor PCB checking	●	●	●	●	×
Self diagnostic function	●	●	●	●	●
Back light	●	●	●	●	●
Built-in temperature sensor	●	●	●	×	●
Wireless control available	●	●	×	×	●
Individual louver control	●	●	●	×	●
Breeze mode	●	●	●	×	×
Motion sensor	×	●	●	×	×
Health(Airpure)	●	●	●	×	●
High-temp sterilization	×	●	×	×	×
Hi-Motion	×	●	×	×	×
ECO (energy saving)	●	●	●	×	●
Quiet (Indoor unit)	●	●	●	×	●
Sleep(Indoor unit)	●	●	●	×	●
Window interlock	●	●	●	×	×
Key card	●	●	●	×	×
3D-air flow	●	●	●	×	●
Child lock	●	●	×	×	×
Self cleaning	●	●	●	×	●
Auto changeover	×	●	×	×	×
Dynamic ESP	●	●	×	×	×
Outlet air temp limit	●	●	×	×	×

Remarks: Available: ● Unavailable: ×

RELIABILITY

EFFICIENCY

COMFORT





FLEXIBILITY

OUTDOOR UNIT

INDOOR UNIT

CONTROL SYSTEM

ACCESSORY

Type	Wired Controller				Wireless Controller
Model	HYXE-VC01	HYXM-VG01	HYXE-VA01A	HYXE-S01H	HYE-VD01
Picture					
4-Way Cassette	○	○	○	○	○
Mini 4-Way Cassette	○	○	○	○	○
1-Way Cassette	○	○	○	×	○
2-Way Cassette	○	○	○	×	○
Ceiling Ducted (AC/DC)	○	○	○	○	○
Ceiling Ducted (High/Low)	○	○	○	○	○
Console	○	○	○	○	●
Wall Mounted	○	○	○	○	●
Floor Standing	○	○	○	×	●
Ceiling & Floor	○	○	○	○	●
Floor Concealed	○	○	○	×	○
All Fresh Air	○	○	○	○	○
Heat Recovery Ventilator	×	×	×	×	×
AHU Kit	○	○	●	×	×

Type	Receiver Kit			Centralized Controller	ON/OFF
Model	HYRE-V02H	HYRE-Z01H	HYRE-T03H	HYJM-RA10D	HYJ-J01H
Picture					
4-Way Cassette	×	×	○	○	○
Mini 4-Way Cassette	×	○	×	○	○
1-Way Cassette	×	×	×	○	○
2-Way Cassette	○	×	×	○	○
Ceiling Ducted (AC/DC)	○	×	×	○	○
Ceiling Ducted (High/Low)	○	×	×	○	○
Console	○	×	×	○	○
Wall Mounted	○	×	×	○	○
Floor Standing	×	×	×	○	×
Ceiling & Floor	○	×	×	○	○
Floor Concealed	○	×	×	○	○
All Fresh Air	○	×	×	○	○
Heat Recovery Ventilator	×	×	×	○	○

Remarks: Standard: ● Optional: ○ Incompatible: ×

Individual Control

Wired Controller

HYXE-VC01



Mode	Cool/Heat/Auto/Fan/Dry
Timer	24-hour timer
Maintenance	Error code/Parameter check/Auto test run/ Self diagnostic function/Indoor & Outdoor PCB checking/ Air filter cleaning reminding/IDU address setting
Louver	7 Louver setting/3D-air flow/Individual louver control
Special function	Health/ECO/Quiet/Sleep/Self-cleaning
Fan speed	6
Temperature setting	0.5°C accuracy/Display the setting temp. or room temp.
Main-sub control	•
Wireless control available	•
Built-in temperature sensor	•

Features

- Size: 86mm × 86mm
- Max. connectable indoor units: 6
- LCD display with back light
- Touch button
- Flat back-cover for easy mounting

HYXM-VG01

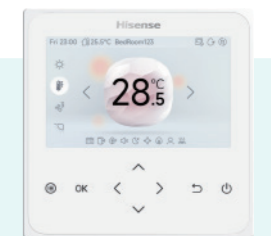

Mode	Cool/Heat/Auto/Fan/Dry
Timer	24-hour/Weekly schedule/Holiday setting
Maintenance	Error code/Parameter check/Auto test run/ Indoor&Outdoor PCB checking/Self diagnostic function
Louver	Louver setting/Individual louver control/3D-air flow
Special function	Breeze mode/Motion sensor/Health/ Hi-Motion/ECO/Quiet/Sleep
Fan speed	6
Temperature setting	0.5°C
Main-sub control	•
Air filter cleaning reminding	•
Back light	•
Built-in temperature sensor	•
Built-in receiver kit	•

Features

- Size: 120mm × 120mm
- Max. connectable indoor units: 16
- Touch button
- Language:
Support 11 languages: English,
French, German, Italian, Spanish,
Dutch, Portuguese, Polish, Turkish,
Russian, Arabic
- Diverse Display Colors
- Brand-new Auto Changeover
- Refrigerant Leakage Alarm

HYXE-VA01A



Features

Mode	Cool/Heat/Auto/Fan/Dry
Timer	72-hour
Maintenance	Error code/Parameter check/Auto test run/ Indoor&Outdoor PCB checking/Self diagnostic function
Louver	Louver setting/Individual louver control/3D-air flow
Special function	Breeze mode/Motion sensor/Health/ECO/Quiet/ Sleep/Self-cleaning
Fan speed	6
Temperature setting	0.5°C
Main-sub control	•
Air filter cleaning reminding	•
Back light	•
Built-in temperature sensor	•

- Size: 120mm × 120mm
- Max. connectable indoor units: 16
- LCD display
- Touch button

Wireless Controller

HYE-VD01



Features

Mode	Cool/Heat/Auto/Fan/Dry
Timer	24-hour timer
Maintenance	Auto test run/Self diagnostic function/ Identification of adjacent receiver
Louver	Louver setting/3D-air flow*/Individual louver control
Special function	Health/ECO/Quiet/Sleep/Self-cleaning
Fan speed	6
Temperature setting	1°C accuracy/Display the setting temp. or room temp.
Built-in temperature sensor	•

- Size: 178.6mm × 47.8mm
- LCD display with back light

*When used to control 3D air-flow Panels, an additional receiver kit of wireless control will be necessary.

HYXE-S01H



Features

Mode	Cool/Heat/Auto/Fan/Dry/Quiet
Timer	24-hour
Maintenance	Error code/Parameter check/Auto test run/ Indoor&Outdoor PCB checking/Self diagnostic function
Louver	Louver setting
Fan speed	6
Temperature control	•
Air filter cleaning reminding	•

- Size: 120mm × 70mm
- Max. connectable indoor units: 16
- LCD display
- Touch button

Receiver Kit for Wireless Control

Standard



HYRE-V02H (Optional)

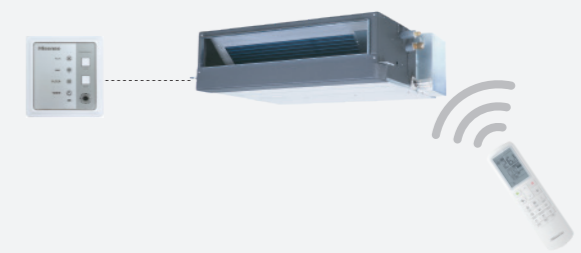

HYRE-Z01H (Optional)

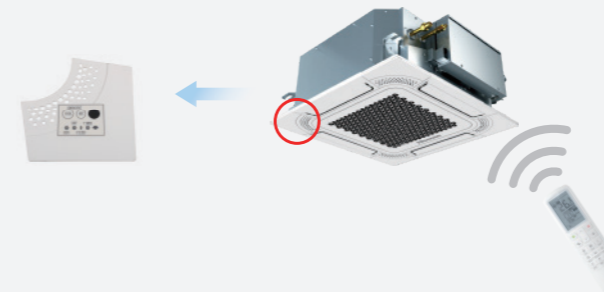

HYRE-T03H (Optional)

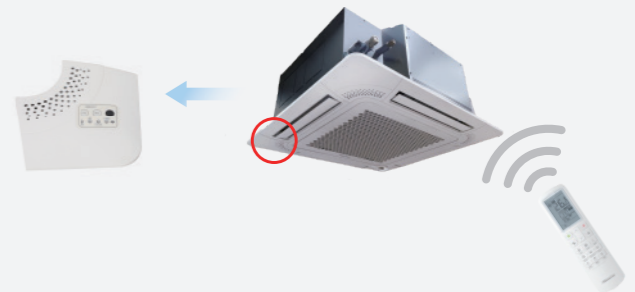

Centralized Control

Smart Touch II
HYJM-RA10D



- Cool/Heat/Auto/Fan/Dry
- Remote control with web access
- Support rotation operation setting
- Weekly/Holiday timer
- Error reminder email
- External input/Output function
- ECO/Health/Self-cleaning/Quiet mode setting of the outdoor unit
- Support OTA update (remotely) and USB update (locally)

Features

- 10 inch colorful touch screen
- 1280 × 800 High Resolution
- Size: 170mm × 252mm × 37mm
- Connected quantity:
160 indoor units, 64 outdoor units
- 14 different languages:
English, French, Spanish, German, Italian, Dutch, Polish, Turkish, Russian, Arabic, Portuguese, Vietnamese, Thai, Chinese

Energy Management

Visualized energy management is available through the Smart Touch II, enabling quick access to electricity consumption data and analysis. Utilizing big data analytics, it also provides energy-saving solutions to help you optimize energy usage efficiently.



Access Remotely with Ease

Users have the flexibility to control the air-conditioning system using either the local Smart Touch II or remote web access.

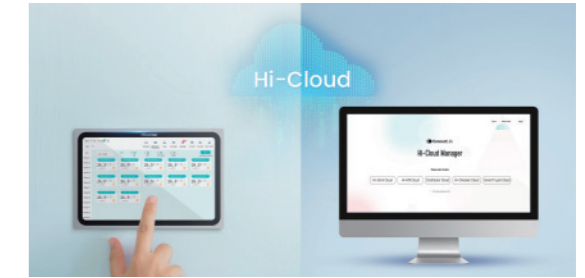

Free Connection

- Max. 4 Smart Touch controllers can be used in one system
- One controller can be connected to max. 160 IDUs, 64 ODUs

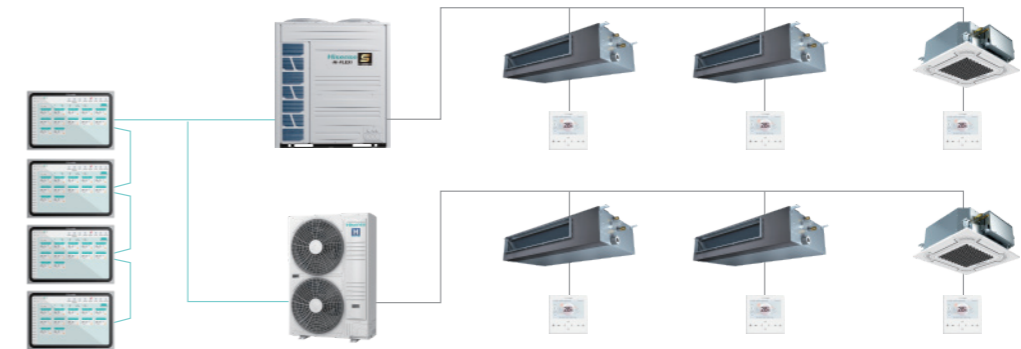

Future-proof

Ensure you stay up to date with both remote OTA updates and local USB updates.

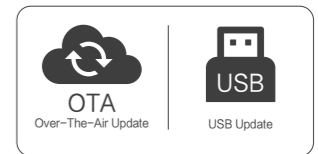

Ideal for:

Offices, Schools, Factories, Hospitals, Hotels, Restaurants



ON/OFF Controller
HYJ-J01H



Features

- Group control (ON/OFF)
- Indoor unit power OFF reminder
- Indoor units Auto log in
- Error reminder
- Size: 120mm × 120mm
- Max. connectable indoor units: 128
- Max. connectable indoor unit groups: 16
- Touch button

Hi-Cloud Manager

Hisense Intelligent Control Solution



Intelligent Control

What is Hi-Cloud Manager?

Hi-Cloud Manager is the unified access management of Hisense HVAC intelligent control. Users can log in the control web at anytime and anywhere.

Five "Clouds" are embed in the web interface including Hi-Mit Cloud, Smart Touch Cloud, Hi-Dom Cloud, Hi-Checker Cloud, and Distributor Cloud (specially for distributors).

Features:

- Centralized remote control
- Overview of key data
- Operation statistics
- Global project map
- Project management
- Regional plane navigation
- Schedule management
- Energy conservation management
- Alarm and message management

URL <https://hicloudmanager.hijuconn.com>

It's recommended to use the Chrome browser.

Users-friendly

- **End user**
Create a customized and smart experience.
- **Distributor**
Upgrade service capabilities for the projects under control.
- **Service engineer**
Ensure efficient service to improve customers' satisfaction.

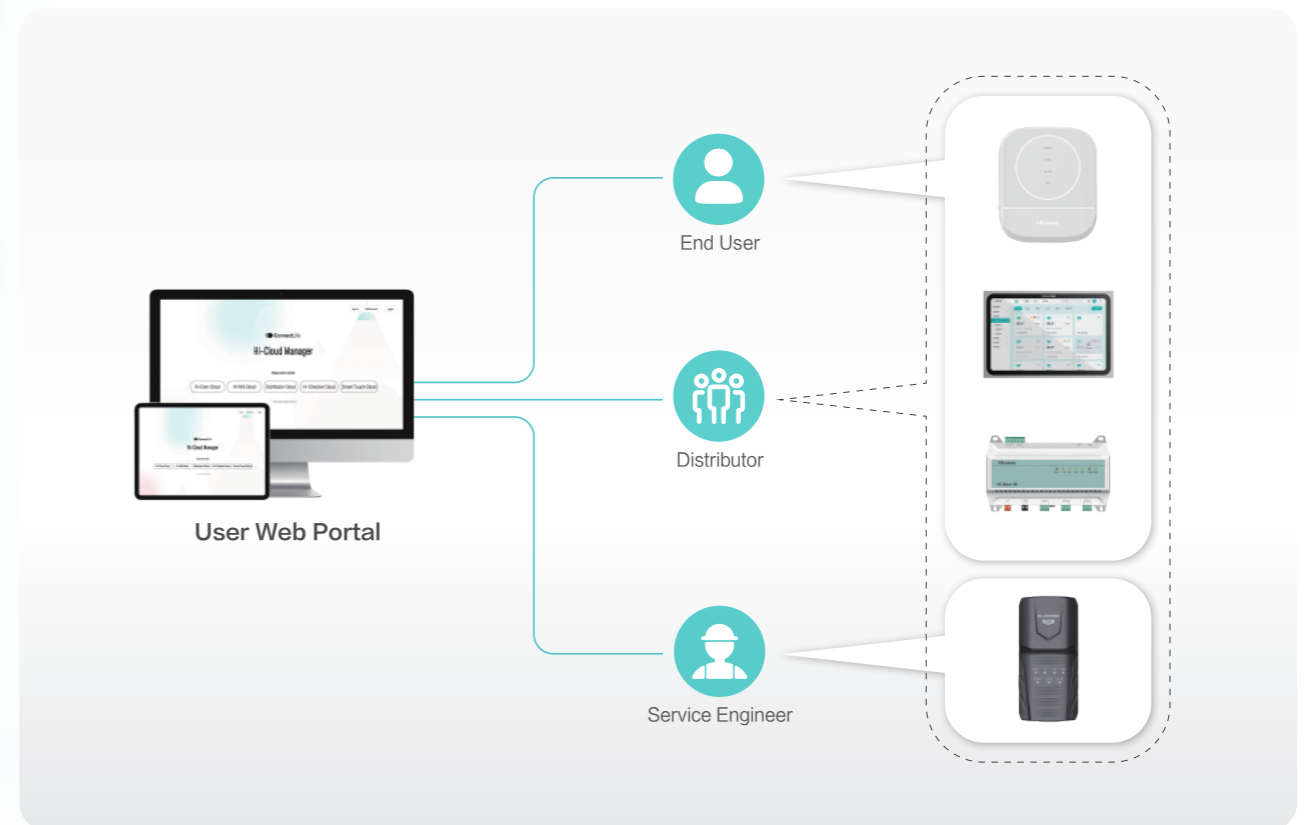



Hi-Mit II

Anytime and anywhere, control is in your hands

One-Click Remote Control

With our Hi-mit App, control your home on-the-go. Turn on the AC during your commute, enjoying the fresh breeze the moment you step into your house. Experience the future of convenience, where your comfort is just a tap away.





Whole-house Voice Control

Hisense VRF system can be connected with Google and Amazon speakers for effortless voice control in your house. Wake up your devices with a simple voice command, adjusting power on/off, setting modes, temperatures, and fan speeds without lifting a finger, freeing you to enjoy a truly hands-free smart living experience.

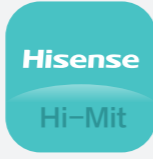

Brand-new Adapter and App

- Stylish appearance and compact body
- Compatible with VRF, hydro box and heat recovery ventilator
- Supporting OTA update
- Simple and intuitive interfaces
- Voice control available

Convenient Control

- 12 languages available
- Energy management
- 2-level permission
- Online repair
- 7x24 schedule setting
- Customized scenes setting

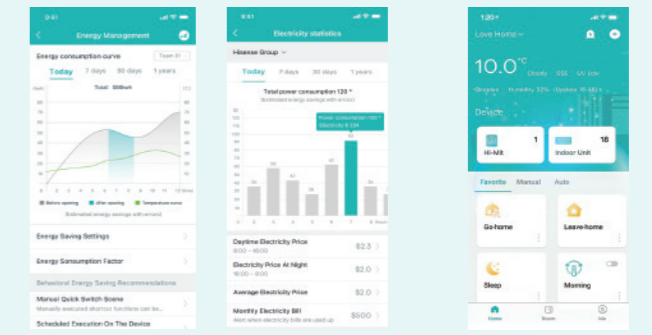

Energy management interface

Customized mode interface

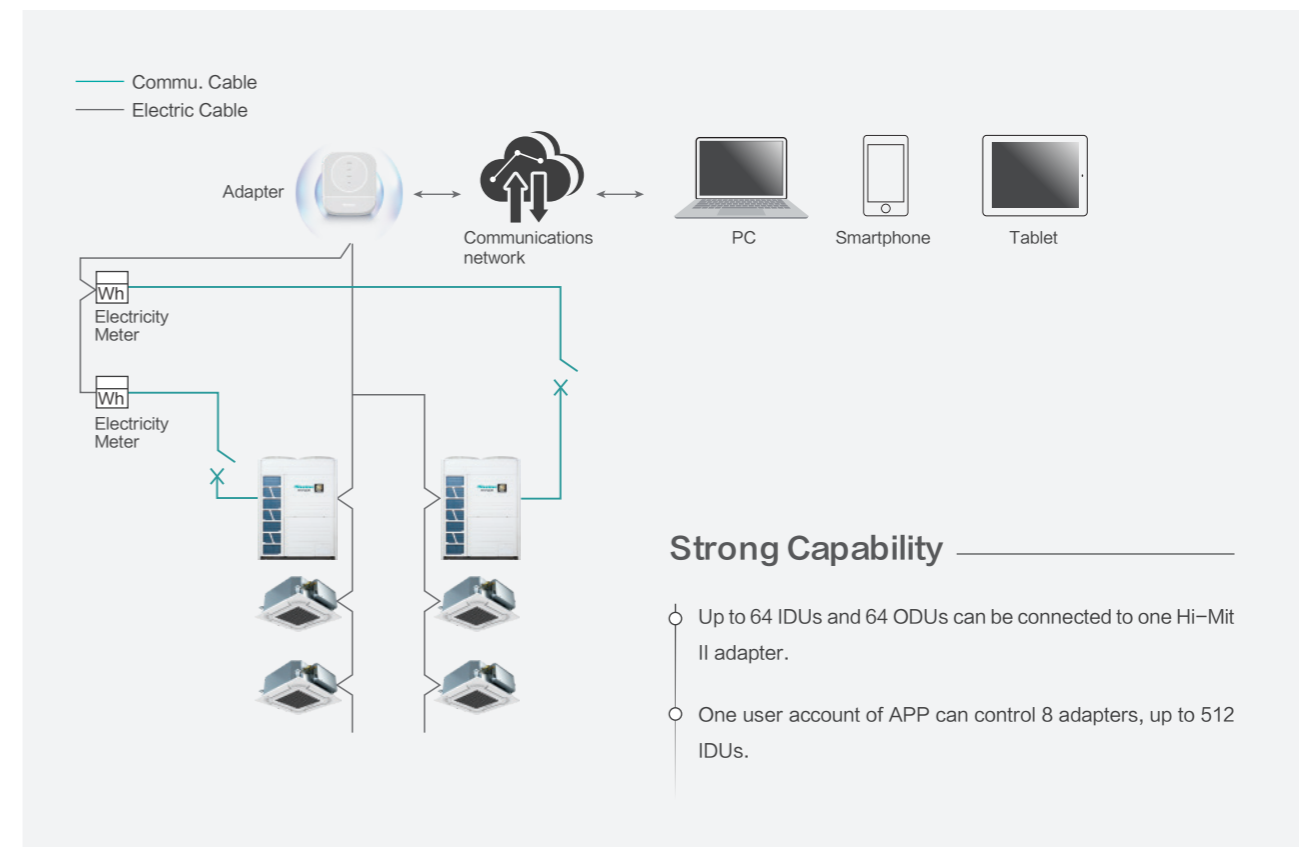

Specifications

Model	Power Supply	Max. Current	Power Input	Dimension	Net Weight
HCCS-H64H2C1M	DC 12V	1A	2.4W	91x117x31mm	0.14kg

Hi-Dom III



Features

- Remote control available
- Multilevel user management
- AC control (on-off, mode, temp, air flow)
- AC locked control (running forbidden control, the max. and min. temp and cooling/heating locked)
- Running according to timer
- Malfunction history check
- Running record display
- Data synchronize
- Supporting for external I/O
- 2D navigation
- Electricity consumption allocation
- Multiple languages available
- Standard with Modbus RTU port

● Humanized interaction interface and comfortable user experience.

● The electricity consumption allocation makes it easy for users to allocate total electricity consumption among building occupants. Both segmented tariff and single tariff are available.

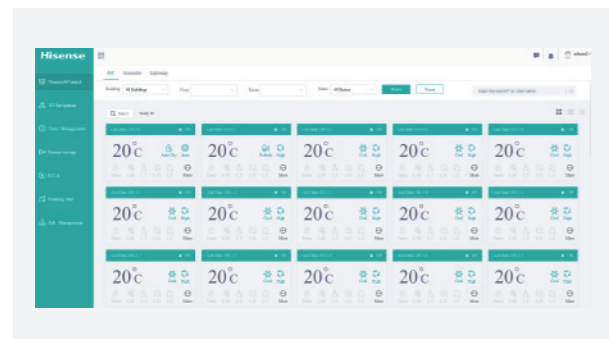

State	Building	Room	Area	APL Device	S.P. S.L. Count	S.P. A.L. Count	S.P. S.L. Count	S.P. A.L. Count	S.P. S.L. Count	S.P. A.L. Count	Total	Block	Stand
...

● Thanks to the 2D navigation, users can import floor plans and place indoor units in the corresponding rooms, creating a tailored system schematic. Thus all the indoor units can be monitored and controlled intuitively.



● Support operation history data record like the below picture. Also the operation data can be exported to excel format, convenient for customers to read.

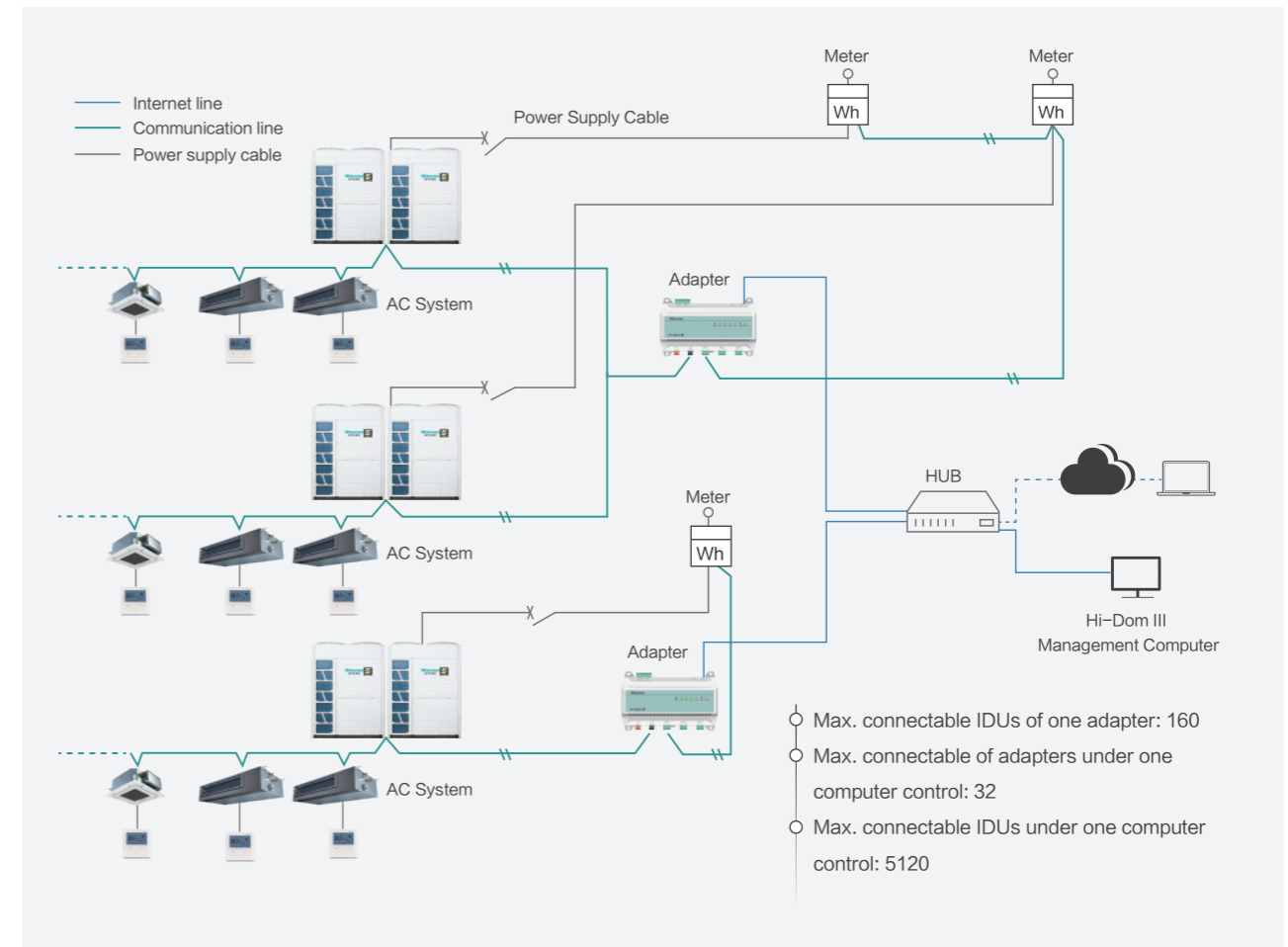
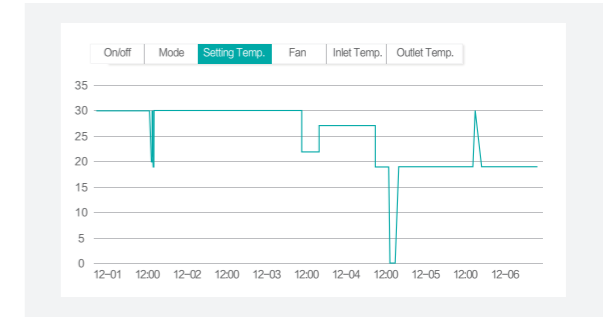

- Max. connectable IDUs of one adapter: 160
- Max. connectable of adapters under one computer control: 32
- Max. connectable IDUs under one computer control: 5120

Specifications

Adapter	Model	Power Supply	Dimension (LxWxD)	Note
	HCCS-H160H2C2YM	12V	180x115.4x64.5mm	With electric charging function
	HCCS-H160H2C2NM	12V	180x115.4x64.5mm	Without electric charging function



Intelligent service tool, improves your service

Hi-Checker is a plug-and-play service tool that allows service engineers to access the system and monitor operational status or data, making system communication and maintenance more convenient. In addition, its cloud-based management also allows remote access to operational status.

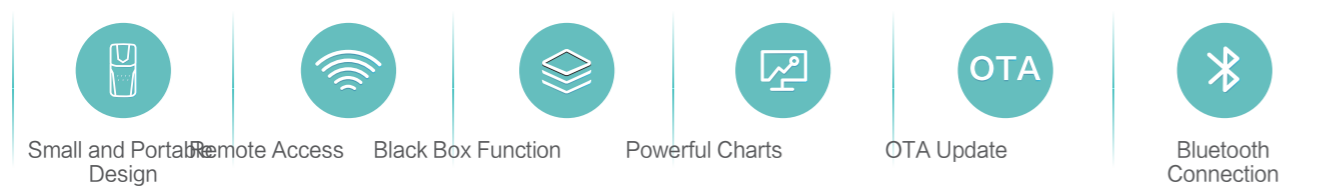

Easy to Use

- Compact size which allows high portability and space saving.
- Capable to slot in a 32G memory card for data collection and storage. Also the memory card and card reader are standard with Hi-Checker.
- Multiple choices of power supply types. It can be powered by the standard adapter (DC 5V), computer or power bank.
- Support OTA update, ensuring the software is always up to date.



Easy to Access

5 Ways to Access the Operation Data

- Conventional connection. The simplest and reliable way by just connecting the Hi-Checker to your computer directly through USB.
- Internet connection. Be connected to a stable Wi-Fi signal to achieve operation data and status monitoring anytime and anywhere.
- Hotspot connection. Be connected to a temporary hotspot signal from the smartphone, allowing the Hi-Checker to remotely monitor the operation data when there is no stable Wi-Fi signal on site.
- SD card storage. Hi-Checker equipped with SD card can be connected to the air conditioning system all the time, so that all the operation data can be stored in the card for later analysis.
- Bluetooth Connection. Connect Hi-Checker to your phone over Bluetooth to access the data on your phone.

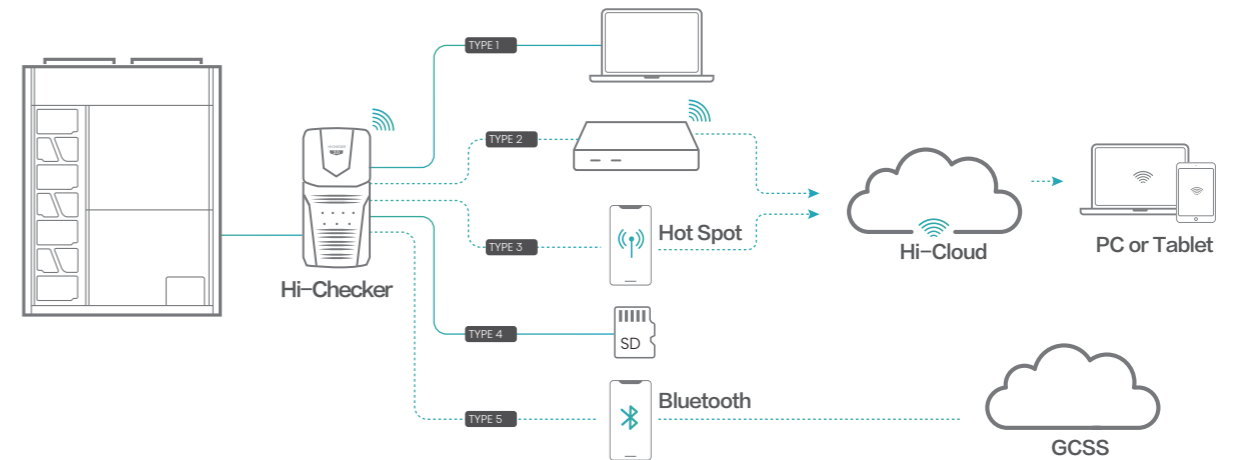

Easy to Understand

- Powerful and detailed chart analysis on the operation data, allowing users to determine the system condition easily. Together with the smart system diagram, it is interesting and easier for maintenance.
- Users can export the professional report either in .csv or .pdf format, very user-friendly.



Easy to Share

- Operation data can be shared between mobile phones and PC.
- Operation data can be shared to the cloud for permanent storage. The cloud storage quota per user is 200MB (around 400 groups of project operational data).
- Operation data can be shared with others via a Share Code.

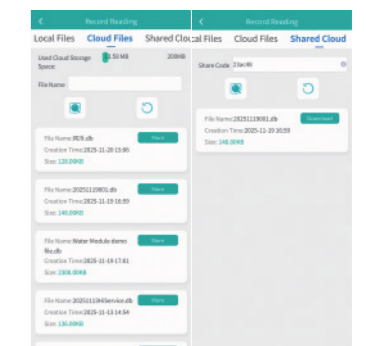

Specifications

Model	Dimension (LxWxH)	Net Weight	Power Supply	Connectable IDUs
HCCS-J64H2C3M	138x68x28mm	0.13kg	5V= 500mA	160

Building Management System

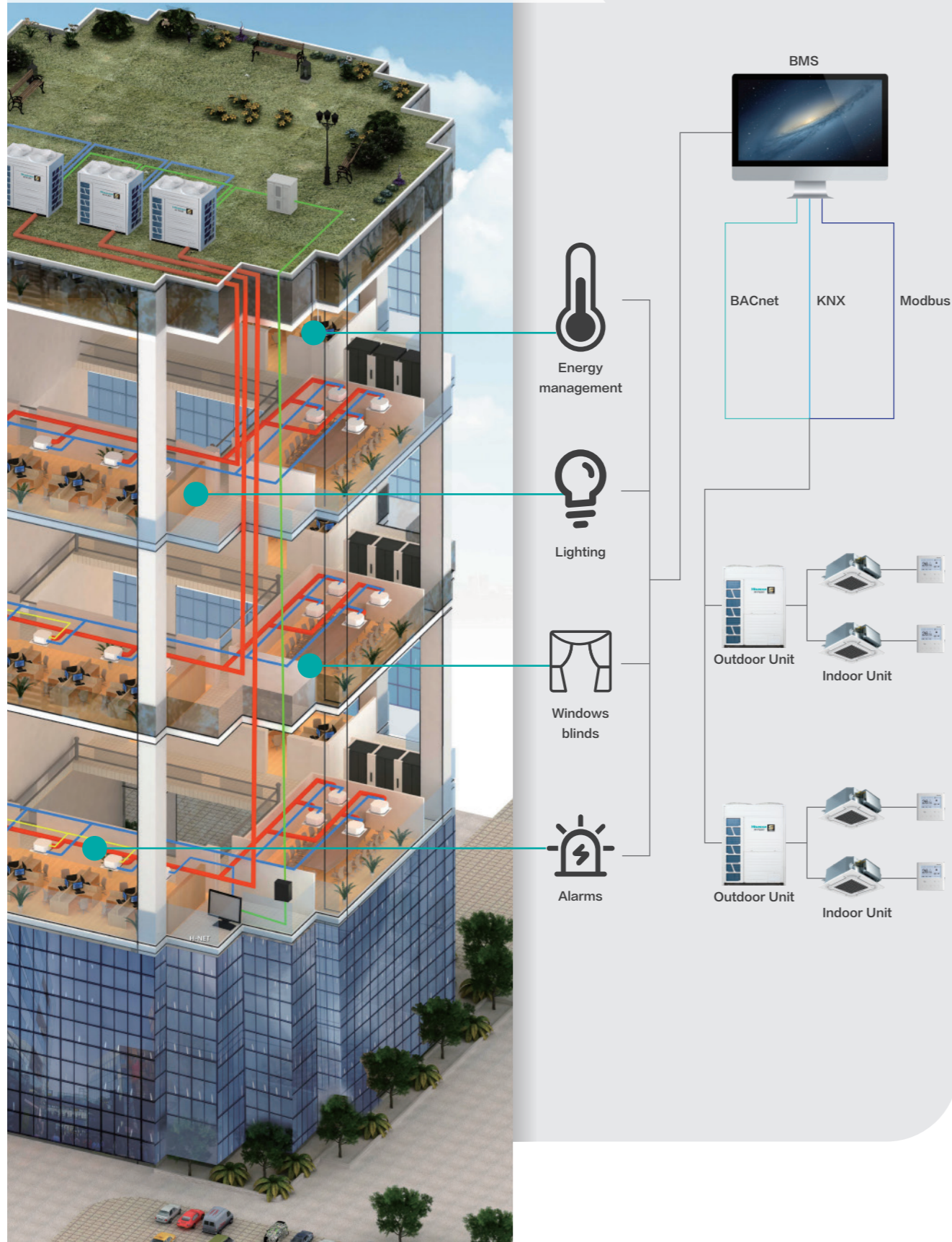

KNX®



KNX gateway	HS-RC-KNX-1i
Power Supply	DC, 29V
Max. Number of Connectable Indoor Units	1
Dimension (H x W x D)	70 x 70 x 28mm
Features	○ Standard data point types
	○ Error code
	○ Directly control of all indoor units
	○ Air filter reminder
	○ Running hours counter
	○

Modbus®



Modbus gateway	HCPC-H2M4C
Power Supply	DC, 12V
Max. Number of Connectable Indoor Units	160
Dimension (H x W x D)	50 x 170 x 220mm
Features	○ On-Off setting
	○ Temperature setting
	○ Operating mode setting
	○ Inlet air temperature monitoring
	○ Airflow setting and monitoring
	○ All units On-Off control
	○ Alarm monitoring and code display
	○ Humidity control
	○

Mini Modbus®



MiniModbus gateway	HCPC-H2M5C
Power Supply	DC, 12V
Max. Number of Connectable Indoor Units	32
Dimension (H x W x D)	27 x 75 x 100mm
Features	○ On-Off Setting
	○ Temperature Setting (0.5°C adjustment)
	○ Airflow Setting (Auto/3 or 6 fan speed)
	○ Humidification control
	○ Operating Mode Setting
	○ Inlet Air Temp. Monitoring
	○ All Units On/Off Control
	○ Alarm Monitoring and Code Display
	○

BACnet® & KNX®



BACnet & KNX gateway	HCPC-H1KB16	HCPC-H1KB64
Power Supply	DC, 12-36V / 3W or AC, 24V/0.2A/50-60Hz or DC, 24V(Recommended)	
Max. Number of Connectable Indoor Units	16	64
Dimension (H x W x D)	100x115x100mm	100x115x100mm
Features	○ Central control of all indoor units	○ Control-vane position swing control
	○ Indoor unit data monitoring	○ Function prohibition of wired controller
	○ Heat/Dry/Fan/Cool/Auto mode	
	○	
	○	
	○	

Note: Bacnet® is a registered trademark of American Society of Heating, Refrigerating and Air-conditioning Engineers (ASHRAE).
 Modbus® is a registered trademark of Schneider Electric.
 KNX® is a registered trademark of Konnex.

ACCESSORIES

ACCESSORIES & ENGINEERING TOOLS

Accessories

Engineering Tools

Accessories

Refrigerant Sensor

Model	Applicable Models	Picture
HOPT-ERD02	R32 refrigerant systems	

Refrigerant Detector

Model	Applicable Models	Picture
HOPT-ERD01	R32 refrigerant systems	

Shut-off Box

Model	Applicable Models	Picture
HESE-2V15	R32 refrigerant systems	

Hi-Motion

Model	Applicable Models	Picture
HCM-S01E	All types of indoor units	

Motion Sensor

Model	Applicable Models	Picture
HPS-MACN	Mini 4-Way Cassette	
HCM-01E	4-Way Cassette	



Fresh Air Duct Adapter



Model	Applicable Models	Picture
HFL-56CSA	4-Way Cassette and Mini 4-Way Cassette	

Humidity Sensor

Model	Applicable Models	Picture
HCHR-S01E	4-Way Cassette, Mini 4-Way Cassette, 1-Way Cassette Console, Ceiling Ducted, Wall Mounted, Floor Standing	

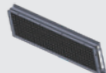
Filter



Filter model	Dimensions (LxWxD) mm	Applicable Models	Grade	Picture
HF-56MQE	343 × 343.5 × 15.0	Mini 4-Way Cassette	G4	
HF-160MQE	527 × 513.0 × 17.0	4-Way Cassette	G4	
HF-280L-FE	Filter: 1100x432.5x20 Frame: 1245x463	AVD-76/96HJDH AVA-76-114HJFDL	G1	

Filter box model	Dimensions (L × W × H) mm	Applicable Models	Grade	Picture
HFB-96LFGDE	1339 × 384 × 462	AVD-76/96HJDH AVA-76-114HJFDL	G4:HF-96HFGDE Coarse filter:HF-96LFGDE	
HFA-1080HP-XFE	1368 × 400 × 394	AVA-48HJFDL	G4+F7+F9	
HFA-3000HP-XFE	1236 × 400 × 502	AVA-76-114HJFDL	G4+F7+F9	

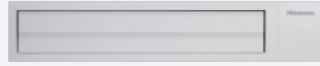
3D Air-flow Panel

Panel Model	Applicable Models	Dimensions (H × W × D) mm	Picture
HP-CB-NA	Ceiling ducted (AC/DC low-height) AVE-05/07/09/12*	180 × 740 × 70	
HP-DB-NA	Ceiling ducted (AC/DC low-height) AVE-15/17*	180 × 950 × 70	
HP-EB-NA	Ceiling ducted (AC/DC low-height) AVE-19/22/24*	180 × 1220 × 70	

AirPure Kit

Model	Power Supply	Applicable Models	Picture
HJK-ELZA	AC 1Φ, 220V~240V 50/60Hz	4-Way Cassette, Mini 4-Way Cassette, 1-Way Cassette	
HJK-ELZB	AC 1Φ, 220V~240V 50/60Hz	Ceiling Ducted, Console	

Drain Pump

Model	Applicable Models	Power Supply	Picture
HPS-F133E	AVD-07-24HJDH / AVD-07-24HCFCCH / AVD-07-24HCFCCL	220-240V/50/60Hz	
HPS-F363E	AVD-24HJDH1 / AVD-30-54HJDH / AVD-27-54HCFCCH / AVD-27-54HCFCCL		
HPS-F134E	AVD-07-24H3FCH	208-230V/60Hz	
HPS-F364E	AVD-27-54H3FCH		
HPS-F8103E	AVD-76/96HJDH	220-240V/50/60Hz	
HPS-151#E	All types of indoor units except wall mounted and floor standing.	220-240V/50/60Hz	

Wind-Snow Protector(For S5 Series)

Model	Applicable Models	Outer Dimensions H × W × D(mm)	Picture
SH-TFF1X	AVWT-76-96HKF5S	Upper: 951 × 803 × 828 Side: 1060 × 722 × 232 Rear: 951 × 697 × 828 Front: 1080 × 188 × 232	
SH-TFF2X	AVWT-114-170HKF5S	Upper: 951 × 943 × 828 Side: 1060 × 722 × 232 Rear: 951 × 837 × 828 Front: 1080 × 328 × 232	
SH-TFF3X	AVWT-190-232HKF5S	Upper: 951 × 1394 × 828 Side: 1060 × 722 × 232 Rear: 951 × 1286 × 828 Front: 1080 × 413 × 232	
SH-TFF4X	AVWT-250HKF5S	Upper: 951 × 1603 × 828 Side: 1060 × 722 × 232 Rear: 951 × 1496 × 828 Front: 1080 × 188 × 232	
SH-TFF5X	AVWT-272-343HKF5S	Upper: 951 × 1885 × 828 Side: 1060 × 722 × 232 Rear: 951 × 1776 × 828 Front: 1080 × 328 × 232	

NFC

Model	Applicable Models	Picture
HNFC-EA1	AVWT-76-1029HKF5S AVW-76-308HKDHE2	

Note: Suitable for S5, H5 Series.

Air Outlet Guide

Model	Applicable Models	Dimensions (HxWxD) mm	Picture
SH-34CD	AVW-27-34HJFAE1	590x590x137	
SH-76CD	AVW-42-76HJFAE1	711x594x137	

Note: Suitable for Hi-Smart A Series.

Piping Connection Kit

There are two types of piping connection kit, non-insulation type and insulation type. The models below are the referenced models without suffix. Please contact with our engineer for detailed model information when ordering.

Manifold Pipe (For outdoor unit)

(Indoor Unit on Left Side)

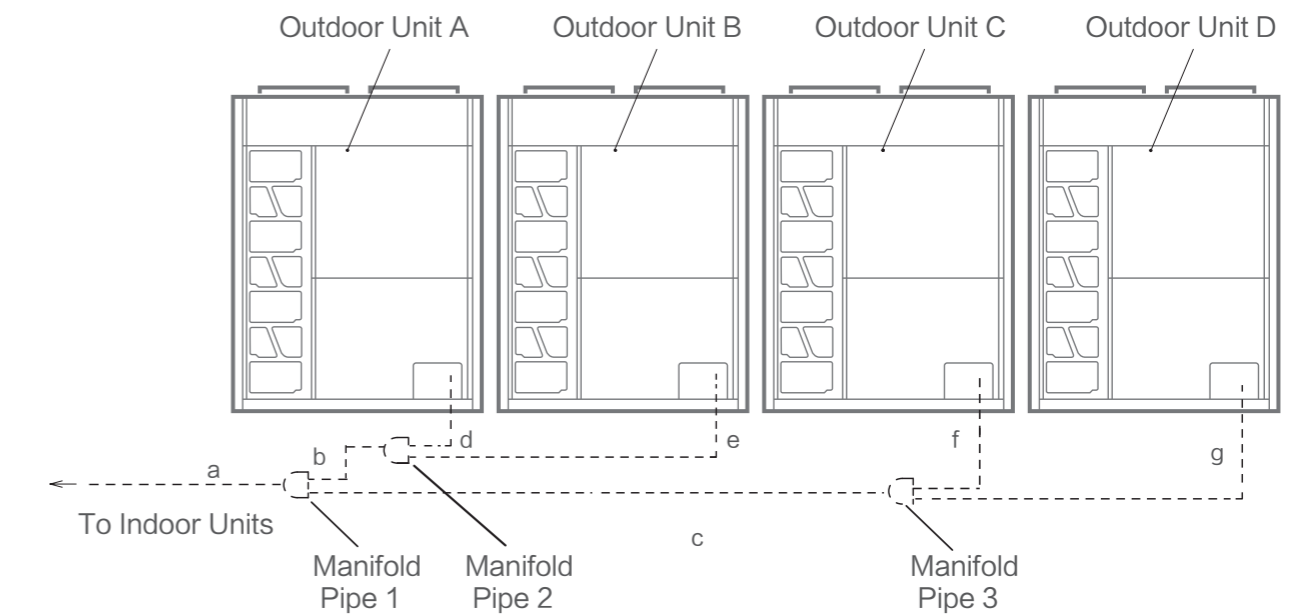

For S5 Series System

Outdoor Unit	AVWT-366-444HKF5S	AVWT-464-686HKF5S	AVWT-714-790HKF5S	AVWT-807-843HKF5S	AVWT-864-1029HKF5S
Manifold Pipe1	HFQ-M32F	HFQ-M462F	HFQ-462F	HFQ-M682F	HFQ-682F
Manifold Pipe2	-	-	HFQ-M462F	HFQ-M462F	HFQ-M462F

For S Series Heat Recovery (Standard) 2 Pipes System

Outdoor Unit	AVWT-250-272FKFSB	AVWT-290-464FKFSB	AVWT-478-510FKFSB	AVWT-530-636FKFSB	AVWT-656-696FKFSB	AVWT-700-928FKFSB
Manifold Pipe1	HFQ-M22F	HFQ-M32F	HFQ-M32F	HFQ-M462F	HFQ-M682F	HFQ-M682F
Manifold Pipe2	-	-	HFQ-M32F	HFQ-M32F	HFQ-M32F	HFQ-M32F
Manifold Pipe3	-	-	-	-	-	HFQ-M32F

For S Series Heat Recovery (Standard) 3 Pipes System

Outdoor Unit	AVWT-250-344FKFSB	AVWT-360-464FKFSB	AVWT-478-510FKFSB	AVWT-530FKFSB	AVWT-550-636FKFSB	AVWT-656-696FKFSB	AVWT-700-720FKFSB	AVWT-740-928FKFSB
Manifold Pipe1	HFQ-M212F	HFQ-M302F	HFQ-M302F	HFQ-M462XF	HFQ-M462XF	HFQ-M682XF	HFQ-M682XF	HFQ-M682XF
Manifold Pipe2	-	-	HFQ-M212F	HFQ-M212F	HFQ-M302F	HFQ-M302F	HFQ-M302F	HFQ-M302F
Manifold Pipe3	-	-	-	-	-	-	HFQ-M212F	HFQ-M302F

For S Series Heat Recovery (High Efficiency) 2 Pipes System

Outdoor Unit	AVWT-228-424FKFSHA	AVWT-444-510FKFSHA	AVWT-530-636FKFSHA	AVWT-648-848FKFSHA
Manifold Pipe1	HFQ-M32F	HFQ-M32F	HFQ-M462F	HFQ-M682F
Manifold Pipe2	-	HFQ-M32F	HFQ-M32F	HFQ-M32F
Manifold Pipe3	-	-	-	HFQ-M32F

For S Series Heat Recovery (High Efficiency) 3 Pipes System

Outdoor Unit	AVWT-228FKFSHA	AVWT-250-340FKFSHA	AVWT-360-424FKFSHA	AVWT-444-510FKFSHA	AVWT-530FKFSHA	AVWT-550-636FKFSHA	AVWT-648-680FKFSHA	AVWT-700-720FKFSHA	AVWT-740-848FKFSHA
Manifold Pipe1	HFQ-M202F	HFQ-M212F	HFQ-M302F	HFQ-M302F	HFQ-M462XF	HFQ-M462XF	HFQ-M682XF	HFQ-M682XF	HFQ-M682XF
Manifold Pipe2	-	-	-	HFQ-M212F	HFQ-M212F	HFQ-M302F	HFQ-M212F	HFQ-M302F	HFQ-M302F
Manifold Pipe3	-	-	-	-	-	-	HFQ-M212F	HFQ-M212F	HFQ-M302F

For S mavo+ Series System

Outdoor Unit	AVWT-290-422HKFSEB	AVWT-444-544HKFSEB	AVWT-478-636HKFSEB	AVWT-656HKFSEB	AVWT-676-696HKFSEB	AVWT-700-848HKFSEB	AVWT-868-888HKFSEB	AVWT-908-928HKFSEB
Manifold Pipe1	HFQ-M32F	HFQ-M462F	HFQ-M462F	HFQ-M682F	HFQ-M682F	HFQ-M682F	HFQ-M682F	HFQ-M682F
Manifold Pipe2	-	-	HFQ-M32F	HFQ-M32F	HFQ-M462F	HFQ-M32F	HFQ-M462F	HFQ-M462F
Manifold Pipe3	-	-	-	-	-	HFQ-M32F	HFQ-M32F	HFQ-M462F

Branch Pipe (For indoor unit)

First Branch Pipe

For S5 Series System

Outdoor Unit HP	8 to 10	12 to 16	18 to 24	26 to 46	48 to 82	84 to 108
Branch Pipe	HFQ-102F	HFQ-162F	HFQ-242F	HFQ-302F	HFQ-462F	HFQ-682F

For S Series Heat Recovery (Standard) 2 Pipes System

Outdoor Unit HP	8 to 10	12 to 16	18 to 24	26 to 54	56 to 66	68 to 96
Branch Pipe	HFQ-102F	HFQ-162F	HFQ-242F	HFQ-302F	HFQ-462F	HFQ-682F

For S Series Heat Recovery (Standard) 3 Pipes System

Outdoor Unit HP	8 to 10	12 to 16	18 to 24	26 to 36	38 to 54	56 to 66	68 to 96
Branch Pipe	HFQ-M282F	HFQ-M452F	HFQ-M562F	HFQ-M692F	HFQ-M902F	HFQ-462XF	HFQ-682XF

For S Series Heat Recovery (High Efficiency) 2 Pipes System

Outdoor Unit HP	8 to 10	12 to 16	18 to 24	26 to 54	56 to 66	68 to 88
Branch Pipe	HFQ-102F	HFQ-162F	HFQ-242F	HFQ-302F	HFQ-462F	HFQ-M682F

For S Series Heat Recovery (High Efficiency) 3 Pipes System

Outdoor Unit HP	8 to 10	12 to 16	18 to 24	26 to 36	38 to 54	56 to 66	68 to 88
Branch Pipe	HFQ-M282F	HFQ-M452F	HFQ-M562F	HFQ-M692F	HFQ-M902F	HFQ-462XF	HFQ-682XF

For S mavo+ Series System

Outdoor Unit HP	8 to 10	12 to 16	18 to 24	26 to 44	46 to 66	68 to 96
Branch Pipe	HFQ-102F	HFQ-162F	HFQ-242F	HFQ-302F	HFQ-462F	HFQ-682F

First Branch Pipe~Last Branch Pipe

For S5 Series System

Total Indoor Unit Hp	Lower than 6	6 to 8.99	9 to 11.99	12 to 15.99	16 to 17.99	18 to 25.99	26 to 35.99	36 to 47.99	48 to 57.99	58 to 83.99	Over 84
Gas (mm)	15.88	19.05	22.2	25.4	28.6	28.6	31.75	38.1	41.3	44.5	50.8
Liquid (mm)	9.53	9.53	9.53	12.7	12.7	15.88	19.05	19.05	22.2	22.2	25.4
Branch Pipe	HFQ-102F	HFQ-102F	HFQ-102F	HFQ-162F	HFQ-162F	HFQ-242F	HFQ-302F	HFQ-302F	HFQ-462F	HFQ-462F	HFQ-682F

For S Series Heat Recovery (Standard) 2 Pipes System

Total Indoor Unit Hp	Lower than 6	6 to 8.99	9 to 11.99	12 to 15.99	16 to 17.99	18 to 25.99	26 to 35.99	36 to 55.99	56 to 57.99	58 to 67.99	Over 68
Gas (mm)	15.88	19.05	22.2	25.4	28.6	28.6	31.75	38.1	41.3	44.5	50.8
Liquid (mm)	9.53	9.53	9.53	12.7	12.7	15.88	19.05	19.05	22.2	22.2	25.4
Branch Pipe	HFQ-102F	HFQ-102F	HFQ-102F	HFQ-162F	HFQ-162F	HFQ-242F	HFQ-302F	HFQ-302F	HFQ-462F	HFQ-462F	HFQ-682F

For S Series Heat Recovery (Standard) 3 Pipes System

Total Indoor Unit Hp	Lower than 6	6 to 8.99	9 to 11.99	12 to 15.99	16 to 17.99	18 to 21.99	22 to 25.99	26 to 35.99	36 to 55.99	56 to 57.99	58 to 67.99	Over 68
Low Pressure Gas (mm)	15.88	19.05	22.2	25.4	28.6	28.6	28.6	31.75	38.1	41.3	44.5	50.8
High/Low Pressure Gas (mm)	12.7	15.88	19.05	22.2	22.2	22.2	25.4	28.6	31.75	38.1	41.3	44.5
Liquid (mm)	9.53	9.53	9.53	12.7	12.7	15.88	15.88	19.05	19.05	22.2	22.2	25.4
Branch Pipe	HFQ-M142F	HFQ-M282F	HFQ-M282F	HFQ-M452F	HFQ-M562F	HFQ-M562F	HFQ-M692F	HFQ-M692F	HFQ-M902F	HFQ-M902F	HFQ-462XF	HFQ-462XF

For S Series Heat Recovery (High Efficiency) 2 Pipes System

Total Indoor Unit Hp	Lower than 6	6 to 8.99	9 to 11.99	12 to 15.99	16 to 17.99	18 to 25.99	26 to 35.99	36 to 55.99	56 to 57.99	58 to 67.99	Over 68
Gas (mm)	15.88	19.05	22.2	25.4	28.6	28.6	31.75	38.1	41.3	44.5	50.8
Liquid (mm)	9.53	9.53	9.53	12.7	12.7	15.88	19.05	19.05	22.2	22.2	25.4
Branch Pipe	HFQ-102F	HFQ-102F	HFQ-102F	HFQ-162F	HFQ-162F	HFQ-242F	HFQ-302F	HFQ-302F	HFQ-462F	HFQ-462F	HFQ-682F

For S Series Heat Recovery (High Efficiency) 3 Pipes System

Total Indoor Unit Hp	Lower than 6	6 to 8.99	9 to 11.99	12 to 15.99	16 to 17.99	18 to 21.99	22 to 25.99	26 to 35.99	36 to 55.99	56 to 57.99	58 to 67.99	Over 68
Low Pressure Gas (mm)	15.88	19.05	22.2	25.4	28.6	28.6	28.6	31.75	38.1	41.3	44.5	50.8
High/Low Pressure Gas (mm)	12.7	15.88	19.05	22.2	22.2	22.2	25.4	28.6	31.75	38.1	41.3	44.5
Liquid (mm)	9.53	9.53	9.53	12.7	12.7	15.88	15.88	19.05	19.05	22.2	22.2	25.4
Branch Pipe	HFQ-M142F	HFQ-M282F	HFQ-M282F	HFQ-M452F	HFQ-M562F	HFQ-M562F	HFQ-M692F	HFQ-M692F	HFQ-M902F	HFQ-M902F	HFQ-462XF	HFQ-462XF

For S mavo+ Series System

Total Indoor Unit Hp	Lower than 6	6 to 8.99	9 to 11.99	12 to 15.99	16 to 17.99	18 to 23.99	24 to 33.99	34 to 45.99	46 to 57.99	58 to 67.99	Over 68
Gas (mm)	15.88	19.05	22.2	25.4	28.6	28.6	31.75	38.1	41.3	44.5	50.8
Liquid (mm)	9.53	9.53	9.53	12.7	12.7	15.88	19.05	19.05	22.2	22.2	25.4
Branch Pipe	HFQ-102F	HFQ-102F	HFQ-102F	HFQ-162F	HFQ-162F	HFQ-242F	HFQ-302F	HFQ-302F	HFQ-462F	HFQ-462F	HFQ-682F

Last Branch Pipe~Indoor Unit

Indoor Unit	Pipe Size (Φ mm)		Max. Liquid Pipe Length
	Gas Pipe	Liquid Pipe	
7kbtu/h~14kbtu/h	12.70	6.35*1	40
17kbtu/h~18kbtu/h	15.88	6.35*1	40
22kbtu/h~54kbtu/h	15.88	9.53	40
76kbtu/h	19.05	9.53	40
96kbtu/h	22.20	9.53	40

Note: 1. When liquid pipe length of indoor unit (07~18kbtu/h) is more than 15m, please change the liquid pipe dimension from Φ6.35 into Φ9.53.

Manifold Pipe Parameter

Unit: mm, ID: Inner Diameter, OD: Outer Diameter.

Model	Gas Line	Liquid Line	Reducer for Gas Line	Reducer for Liquid Line
HFQ-M22F#E HFQ-M22F#ES				
HFQ-M32F#E HFQ-M32F#ES				Qty: 1
				Qty: 1
				Qty: 1

Manifold Pipe Parameter

Model	Gas Line	Liquid Line	Reducer for Gas Line	Reducer for Liquid Line
HFQ-M462F#E HFQ-M462F#ES				
HFQ-M682F#E HFQ-M682F#ES				

Model	Low Pressure Gas Line	High Pressure Gas Line	Liquid Line	Reducer for Low Pressure Gas Line	Reducer for High Pressure Gas Line	Reducer for Liquid Line
HFQ-M202F#E						
HFQ-M212F#E						
HFQ-M302F#E						
HFQ-M462XF#ES						
HFQ-M682XF#ES						

Note: The model with #E stands for non-insulation type, while with #ES represents insulation type.

Branch Pipe Parameter

Model	Low Pressure Gas Line	High Pressure Gas Line	Liquid Line	Reducer for Low Pressure Gas Line	Reducer for High Pressure Gas Line	Reducer for Liquid Line
HFQ-M142F#E						
HFQ-M282F#E						
HFQ-M452F#E						
HFQ-M562F#E						
HFQ-M692F#E						
HFQ-M902F#E						
HFQ-462XF#ES						
HFQ-682XF#ES						

Note: The model with #E stands for non-insulation type, while with #ES represents insulation type.

Branch Pipe Parameter

Model	Gas Line	Liquid Line	Reducer for Gas Line	Reducer for Liquid Line
HFQ-052F#E			—	—
HFQ-102F#E HFQ-102F#ES			—	 Q'ty : 2
HFQ-162F#E HFQ-162F#ES			 Q'ty: 1	 Q'ty: 1
HFQ-242F#E HFQ-242F#ES			 Q'ty: 1	 Q'ty: 1
HFQ-302F#E HFQ-302F#ES			 Q'ty: 1 Q'ty: 1 Q'ty: 1	 Q'ty: 1
HFQ-462F#E HFQ-462F#ES			 Q'ty : 1 Q'ty : 2	 Q'ty : 1
HFQ-682F#E HFQ-682F#ES			 Q'ty : 1 Q'ty : 2 Q'ty : 2	 Q'ty : 2 Q'ty : 1 Q'ty : 2

Note: The model with #E stands for non-insulation type, while with #ES represents insulation type.

Branch Header

Model	Gas Line	Liquid Line	Closing Pipe	Expander
HFQ-064HFD			 (2 pc)	 (4 pc)
HFQ-068HFD			 (6 pc)	 (2 pc)
HFQ-0610HFD			 (8 pc)	 (2 pc)
			 (8 pc)	 (10pc)

Branch Header for A Series

Unit:mm

Model	ØN	ØM	Gas side joint(ØN-ØM)	ØP	Liquid side joint(Ø9.53-ØP)	Insulation
HFQ-082TF#EN	15.88	12.7		6.35		
HFQ-102TF#EN	19.05	15.88		9.53		
HFQ-083TF#EN	15.88	12.7		6.35		
HFQ-103TF#EN	19.05	15.88		9.53		
HFQ-084TF#EN	15.88	12.7		6.35		
HFQ-104TF#EN	19.05	15.88		9.53		
HFQ-085TF#EN	15.88	12.7		6.35		
HFQ-105TF#EN	19.05	12.7		6.35		
HFQ-086TF#EN	15.88	12.7		6.35		
HFQ-106TF#EN	19.05	12.7		6.35		
ADAPTER						
HPI-E1215N						
HPI-E0609N						
HPI-E1519N1						
HPI-E0912N						

Flare-nuts Branch Pipe for A Series

Model	Gas	Liquid
HFQ-052F#EN 1		
HFQ-052F#EN 2		
HFQ-052F#EN 3		